

VIBRATORY ROLLER

Operation and Maintenance Manual



124010 - 73" SMOOTH VIBRATORY ROLLER
124015 - 73" PAD FOOT VIBRATORY ROLLER

124030 - 84" SMOOTH VIBRATORY ROLLER
124035 - 84" PAD FOOT VIBRATORY ROLLER



*Register your
WARRANTY
within 30 days
of purchase*



888-376-7027 | BlueDiamondAttachments.com

TABLE OF CONTENTS

Safety Information	1	Service	7
Introduction	1	Torque Chart	7
Safety Precautions	1	Service Tools	7
Safety Decals	1	Replacing Shockmounts.....	7
Specifications	3	Replacing Input Seal	7
Operation	4	Removing Drive Coupler	7
Introduction	4	Installing Drive Coupler	8
Before Starting & Operating	4	Removing Exciter Bearings and Shaft.....	8
Connecting to Loader	4	Installing Exciter Bearings and Shaft.....	8
Operating	4	Parts Replacement Cycles and Tolerances	9
Maintenance	5	Replacement Parts	11
Maintenance Schedule	5	Drum Assembly	12
Fluid Levels.)	5	Main Assembly	14
Changing Exciter Oil	5	Spider Assembly	16
Checking Exciter Oil	6	Warranty	18

This Page Intentionally Left Blank

SAFETY INFORMATION

Introduction



This Safety Alert Symbol is used to call attention to items or operations which may be dangerous to those operating or working with this equipment. The symbol can be found throughout this manual and on the unit. Please read these warnings and cautions, along with all decals, carefully before attempting to operate the unit. Make sure every individual who operates or works with this equipment is familiar with all safety precautions.



GENERAL WARNING. Indicates information important to the proper operation of the equipment. Failure to observe may result in damage to the equipment and/or severe bodily injury or death.



GENERAL CAUTION. Indicates information important to the proper operation of the equipment. Failure to observe may result in damage to the equipment.

Safety Precautions



LETHAL EXHAUST GAS: An internal combustion engine discharges carbon monoxide, a poisonous, odorless, invisible gas. Death or serious illness may result if inhaled. Operate only in an area with proper ventilation. **NEVER OPERATE IN A CONFINED AREA!**



DANGEROUS FUELS: Use extreme caution when storing, handling and using fuels, as they are highly volatile and explosive in vapor state. Do not add fuel while engine is running. Stop and cool the engine before adding fuel. **DO NOT SMOKE!**



SAFETY GUARDS: It is the owner's responsibility to ensure that all guards and shields are in place and in working order.



IGNITION SYSTEMS: Breakerless, magneto, and battery ignition systems can cause severe electrical shocks. Avoid contacting these units or their wiring.



SAFE DRESS: Do not wear loose clothing, rings, wristwatches, etc. near machinery.

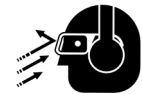

NOISE PROTECTION: Wear OSHA specified hearing protection devices.



EYE PROTECTION: Wear OSHA specified eye shields, safety glasses, and sweat bands.



FOOT PROTECTION: Wear OSHA specified steel-tipped safety shoes.



HEAD PROTECTION: Wear OSHA specified safety helmets.



DUST PROTECTION: Wear OSHA specified dust mask or respirator.

OPERATOR: Keep children and bystanders off and away from the equipment.

REFERENCES: For details on safety rules and regulations in the United States, contact your local Occupational Safety and Health Administration (OSHA) office. Equipment operated in other countries must be operated and serviced in accordance and compliance with any and all safety requirements of that country. The publication of these safety precautions is done for your information. Blue Diamond does not by the publication of these precautions, imply or in any way represent that these are the sum of all dangers present near Blue Diamond equipment. If you are operating Blue Diamond equipment, it is your responsibility to insure that such operation is in full accordance with all applicable safety requirements and codes. All requirements of the United States Federal Occupational Safety and Health Administration Act must be met when operated in areas that are under the jurisdiction of that United States Department.

Safety Decals

Carefully read and follow all safety decals. Keep them in good condition. If decals become damaged, replace as required. If repainting the unit, replace all decals. Decals are available from authorized Blue Diamond distributors. Order the decal set listed on the following page(s).

Hydraulic Requirements

PRESSURE: 1500-3000 psi
(103-207 bar)

FLOW: 10-50 gpm
(38-190 l/m)

← Return

← Pressure

14435

14435

CAUTION



HEAVY ATTACHMENT

Overloading skid loader could cause loader to pitch or tip forward.

Check lifting capacity of skid loader before hooking onto attachment.

Do not lift attachment over 12" (30cm) above ground level.



READ OPERATORS MANUAL BEFORE USING ATTACHMENT

14434

14434

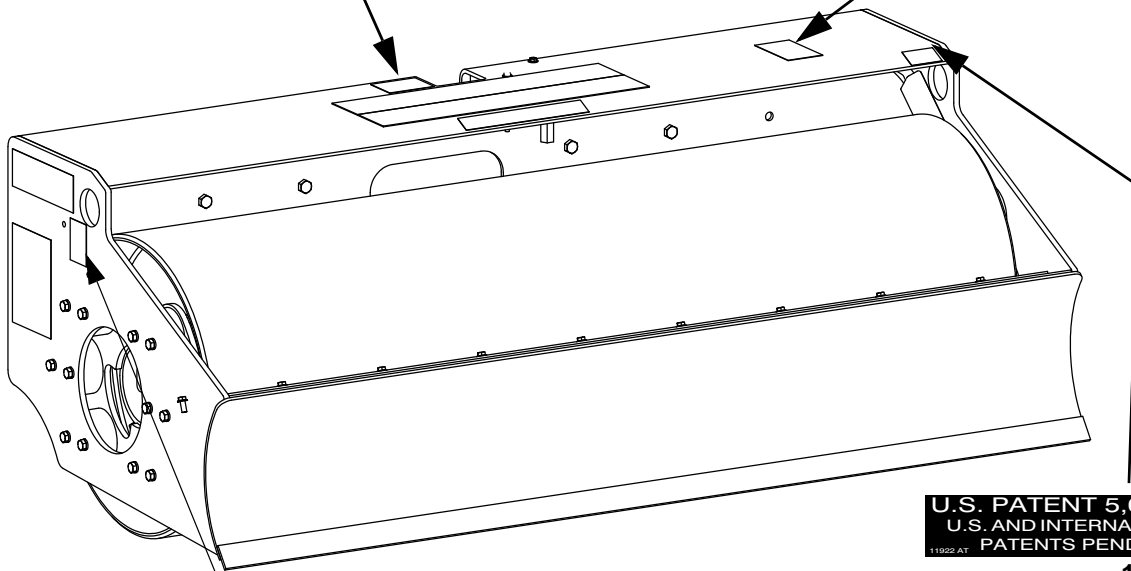

U.S. PATENT 5,062,228
U.S. AND INTERNATIONAL PATENTS PENDING

11922 AT

11922

WARNING

Machine may fall and cause serious damage or injury if lifted improperly.
Lift only by holes in frame above.

MACHINE WEIGHT

ATS84- 2260 lbs (1025 kg)
ATP84- 2410 lbs (1093 kg)

18075

18075-AT84

18074-AT74 (Not Shown)

Safety Decals (Decal Set #14436)

SPECIFICATIONS

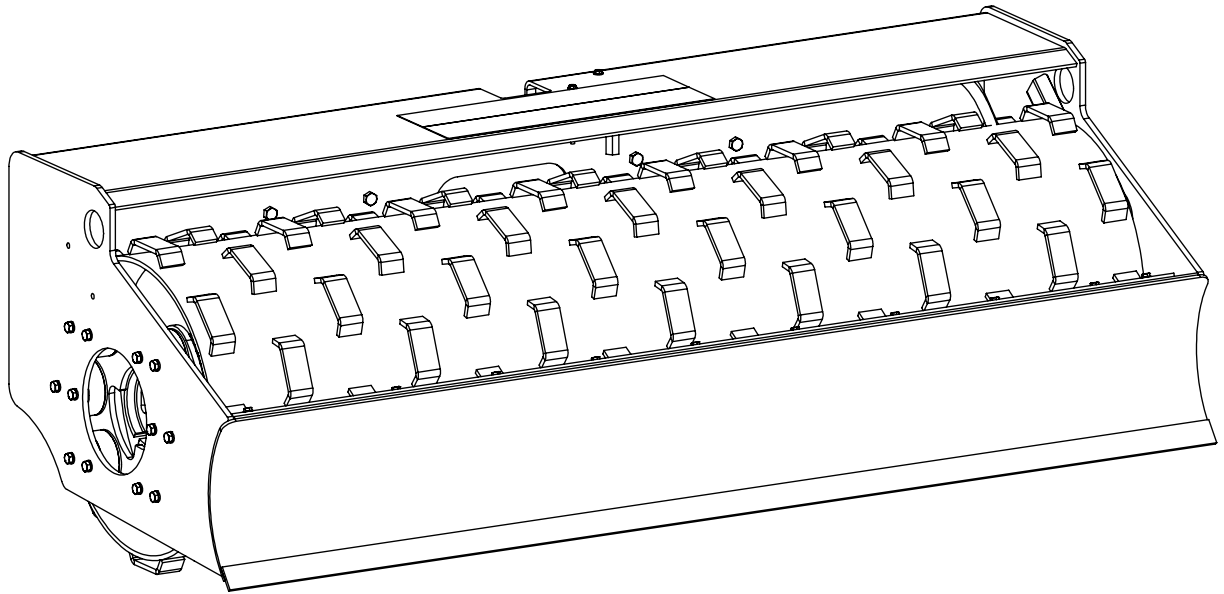

	124010	124015	124030	124035
Centrifugal Force	8850 lbs (4014 kg)		9765 lbs (4429 kg)	
Exciter Speed	3000 rpm		3000 rpm	
Dynamic Linear Force	121 lb/in (21.7 kg/cm)		116 lb/in (20.8 kg/cm)	
Amplitude	-		-	
Length	43.3 in (110 cm)		43.3 in (110 cm)	
Height	29 in (74 cm)	30 in (76 cm)	29 in (74 cm)	30 in (76 cm)
Weight	2070 lbs (939kg)	2210 lbs (1002 kg)	2300 lbs (1043 kg)	2450 lbs (1111 kg)
Width, Working	73 in (185 cm)		84 in (213 cm)	
Width, Overall	78 in (198 cm)		89 in (226 cm)	
Sound Pressure Level	85 dBa		85 dBa	
Pressure Requirement	1500 - 3000 psi (10.3 - 20.7 MPa)		1500 - 3000 psi (10.3 - 20.7 MPa)	
Flow Rate Requirement	10 - 50 GPM (38 - 176 LPM)		10 - 50 GPM (38 - 176 LPM)	
Connection	1/2" Flat-face Quick Coupling		1/2" Flat-face Quick Coupling	

Specifications subject to change without notice

OPERATION

Introduction

Blue Diamond equipment is intended for use in very severe applications.

This parts manual contains only standard parts. Variations of these parts as well as other special parts are not included. Contact your local Blue Diamond distributor for assistance in identifying parts not included in this manual.

Before Starting & Operating

- **REMEMBER!** It is the owner's responsibility to communicate information on the safe use and proper operation of this unit to the operators.
- Review ALL of the Safety Precautions listed on page 1 of this manual.
- Familiarize yourself with the operation of the machine and confirm that all controls function properly.
- Know how to STOP the machine in case of an emergency.
- Make sure hands, feet, and clothing are at a safe distance from any moving parts.

Connecting to Loader

1. Attach the roller to the skid steer loader with the universal bracket. Be sure that the wedges and levers are fully engaged and locked.
2. Connect the hydraulic hoses to the skid steer loader's auxiliary hydraulics supply using the quick couplers.
3. If skid loader is equipped with a high flow and low flow ports, it is recommended to use the low flow side.

4. Lower the roller, and engage the loaders' arms into their float mode.
5. Engage the auxiliary hydraulics and allow the vibrator to come up to speed.

Operating

- Check for loose hardware every 20 hours of operation.
- Do not run exciter when roller is not in contact with the ground.
- Check that rated capacity of skid steer loader meets or exceeds weight of roller attachment.
- The operating pressure supplied to the control valve must fall in the range of 1500 to 3000 psi.
- The minimum volume requirement supplied to the control valve is 10 gpm, but do not exceed 50 gpm.
- Do not use excessive down pressure when compacting soil.



WARNING



Always stop the engine before:

Adding fuel.

Leaving the equipment unattended for any amount of time.

Before making any repairs or adjustments to the machine.

MAINTENANCE



WARNING



Always exercise the stopping procedure before servicing or lubricating the unit.

After servicing the unit, replace and fasten all guards, shields, and covers to their original positions before resuming operation.



CAUTION



Always verify fluid levels and check for leaks after changing fluids.

Do not drain oil onto ground, into open streams, or down sewage drains.

Maintenance Schedule

SYSTEM	MAINTENANCE	EACH USE	EVERY 50 HOURS	EVERY 250 HOURS	YEARLY
Exciter	Check oil level		X		
	Check for oil leaks	X			
	Change oil			X	X
	Tighten Bolts ¹		X		X
Hardware	Check and tighten as needed ¹		X		X
Shock mounts	Check for cracks or tears		X		X

1. Check all hardware after the first 5 hours of use, then follow the maintenance schedule.

Fluid Levels.)

SYSTEM	FLUID VOLUME	RECOMMENDED OIL
73" Exciter	80 oz.	224515 32 Oz. Bottle Exciter Oil
84" Exciter	128 oz.	224515 32 oz. Bottle Exciter Oil

Changing Exciter Oil

1. Rotate drum until the fill/drain plug is at bottom of

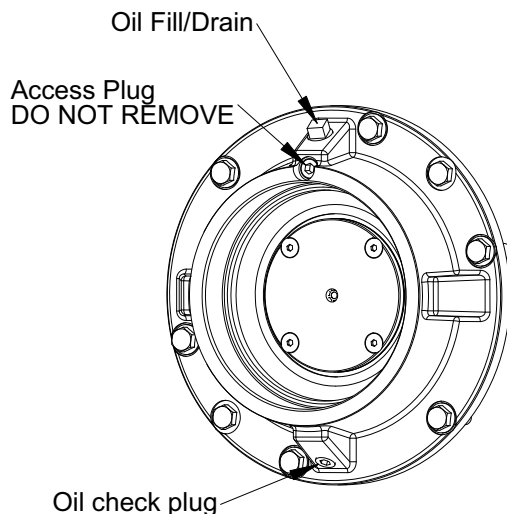

drum. The fill/drain plug is the larger, square head plug on the vent side of the roller.

- Place drain pan under plug and remove both plugs.
- Raise driven side of drum several inches so all oil can drain out.
- After all oil has drained, return drum to a level surface.
- Rotate drum until fill/drain plug is at the top of the drum.
- Remove oil check plug from bottom of cover. The oil check valve is smaller than the fill plug, and it has an allen head drive as opposed to the square head found on the fill/drain plug.
- Fill exciter with Oil until oil starts to drain from oil check plug. See chart for proper amounts.
- Replace both plugs.

Checking Exciter Oil

1. Place drum on a level surface
2. Remove oil check plug. The plug is the smaller of the two on the vent side which also has an allen head drive.
3. Rotate drum until check plug is at 6 o'clock position.
4. If oil level is adequate, it should dribble out of hole.
5. If necessary, remove fill/drain plug, and add Blue Diamond approved Oil.

SERVICE

Assembly and disassembly should be performed by a service technician who has been factory trained on Blue Diamond equipment. The unit should be clean and free of debris. Pressure washing before disassembly is recommended.

- Prior to assembly, wash all parts in a suitable cleaner or solvent.
- Check moving parts for wear and failure. Refer to the Replacement section in this manual for tolerance and replacement cycles.
- All shafts and housings should be oiled prior to pressing bearings. Also, ensure that the bearings are pressed square and are seated properly.
- All bearings should be replaced when rebuilding any exciter or gearbox.
- All gaskets and seals should be replaced after any disassembly.

Torque Chart

SIZE	GRADE 2	GRADE 5	GRADE 8
1/4-20	49 in•lbs	76 in•lbs	9 ft•lbs
1/4-28	56 in•lbs	87 in•lbs	10 ft•lbs
5/16-18	8 ft•lbs	13 ft•lbs	18 ft•lbs
5/16-24	9 ft•lbs	14 ft•lbs	20 ft•lbs
3/8-16	15 ft•lbs	23 ft•lbs	33 ft•lbs
3/8-24	17 ft•lbs	26 ft•lbs	37 ft•lbs
7/16-14	24 ft•lbs	37 ft•lbs	52 ft•lbs
7/16-20	27 ft•lbs	41 ft•lbs	58 ft•lbs
1/2-13	37 ft•lbs	57 ft•lbs	80 ft•lbs
1/2-20	41 ft•lbs	64 ft•lbs	90 ft•lbs
9/16-12	53 ft•lbs	82 ft•lbs	115 ft•lbs
5/8-11	73 ft•lbs	112 ft•lbs	159 ft•lbs
5/8-18	83 ft•lbs	112 ft•lbs	180 ft•lbs
3/4-16	144 ft•lbs	200 ft•lbs	315 ft•lbs
1-8	188 ft•lbs	483 ft•lbs	682 ft•lbs
1-14	210 ft•lbs	541 ft•lbs	764 ft•lbs
1-1/2-6	652 ft•lbs	1462 ft•lbs	2371 ft•lbs
M 6	3 ft•lbs	4 ft•lbs	7 ft•lbs
M 8	6 ft•lbs	10 ft•lbs	18 ft•lbs
M 10	10 ft•lbs	20 ft•lbs	30 ft•lbs

CONVERSIONS

in•lbs x 0.083 = ft•lbs

ft•lbs x 12 = in•lbs

ft•lbs x 0.1383 = kg•m

ft•lbs x 1.3558 = N•m

Service Tools

Part #	Description
07353	CLUTCH REMOVAL TOOL

Replacing Shockmounts

1. Support roller to prevent it from rolling, and remove hydraulic hoses from motor.
2. Remove the two bolts securing the hydraulic motor and remove the motor.
3. Remove all external shockmount hardware while supporting frame. Lift frame assembly off of drum assembly.
4. Pull spider off of drum.
5. Replace shockmounts as needed.
6. While spider is removed, inspect coupling and seal for excessive wear. Replace if needed.
7. Reinstall spider onto drum and then into the frame
8. Install motor, align with coupler and secure with mounting screw and lock washer. Use a medium strength thread locker. Make sure motor mount surface bottoms out in frame.
9. Connect hoses.

Replacing Input Seal

Refer to Main Assembly, page 14.

1. Remove drum assembly from frame and spider from drum (See "replacing shockmounts" steps 1-4)
2. Using a seal puller, remove seal. Note it is not necessary to remove gear coupler (#15)
3. Inspect the sealing surface on the shaft for wear or damage.
4. If the shaft has any sign of wear or damage, remove the gear coupler (#15) and use the sleeve included with seal. (Follow instructions included with seal kit). If the shaft is in good condition install only the seal. Use a seal protector when installing the seal.

Removing Drive Coupler

Refer to Main Assembly, page 14.

1. Remove hydraulic lines from motor.
2. Remove hydraulic motor (# 6).
3. Remove drive coupler (# 13) gear from motor by loosening clamping screw.

4. To remove coupler gear (# 15) from exciter shaft will require 07353 clutch removal tool. Turn coupler gear clockwise (left hand threads) to remove.

Installing Drive Coupler

Refer to Main Assembly, page 14.

1. Install new coupler gear (# 15) into shaft. Make sure coupler bottoms out. Use high strength threadlocker.
2. Slide new coupler gear on to motor splines and tighten clamping screw. Use a medium strength thread locker on the screw.
3. Install motor (# 6), align with coupler and secure with mounting screw (# 23) and lock washer (# 24). Use a medium strength thread locker. Make sure motor mount surface bottoms out in frame.
4. Connect hoses.

Removing Exciter Bearings and Shaft.

Whenever a complete disassembly is done all bearings, gaskets, O-rings and seals should be replaced.

Refer to Drum Assembly, page 12.

1. Drain exciter oil (Refer to Changing Exciter Oil, page 5.)
2. Remove drum assembly from frame and spider from drum (Refer to Replacing Shockmounts, page 7. Steps 1-4).
3. Remove input seal (# 10) from housing (# 14) using a seal puller.
4. Remove snap ring (# 9) from exciter shaft through seal bore.
5. Remove six bolts (# 19), securing housing (#14), to the drum.
6. Remove two push off bolts (# 19)
7. Thread two 3/8-16x1 1/2 bolts into these push off holes evenly and push cover (# 14) off of drum. (If bolts are not threaded in evenly the cover will bind) Remove cover.
8. Slide exciter shaft (#13) out of drum.
9. Repeat steps 5-7 to remove cover (# 5) from the other side.
10. Remove breather cover (# 11) by removing four screws (# 17).
11. Remove bearings (# 8) from covers (# 5 & 14). (Bearings must be replaced if removed from covers)

Installing Exciter Bearings and Shaft.

Refer to Drum Assembly, page 12.

1. Install new bearings (# 8) into housings (# 5 & 14). Use oil on the OD of the bearing and press on the outer race of the bearing. Failure to do so will result in damage to the bearings.
2. Install new O-rings (# 7) onto housing (# 5 & 14), lightly grease O-ring and housing surface which slides into the drum.
3. Install exciter shaft (# 13) into drum. Leave seal side of exciter assembly stick out of the drum about 12".
4. Take the seal side housing assembly (# 14), lightly oil the exciter shaft bearing journal and apply Loctite 515 gasket eliminator, or equivalent, to mating flange. Slide housing assembly onto shaft and install snap ring (# 9) through seal bore onto shaft. Do not install seal at this time.
5. Slide exciter shaft and housing assembly into drum. Use care to press housing in evenly. Secure with six bolts (# 19). Use medium strength thread locker. Install two bolts (# 18) in the push out holes to protect the threads.
6. To aid in assembly, insert a piece of 3/4" round stock in the vent end of the exciter shaft. Take vent side housing assembly (# 5), apply a light coat of oil to the exciter shaft bearing journal, and Loctite 515 gasket eliminator, or equivalent, to the mating flange. Slide housing assembly over the 3/4" round stock, exciter shaft, and onto drum assembly. Have someone lift up the exciter shaft while aligning the housing assembly with mounting holes in the drum and slide the assembly on evenly.
7. Install the six bolts (# 19) use medium strength thread locker. Install two bolts (# 18) in the push out holes to protect threads. Make sure exciter assembly rotates freely.
8. Remove 3/4" round stock and install vent cover (# 11). Make sure felt filter (# 1), retainer (# 2) and spiral pin (# 15) are in place.
9. Press seal into housing (# 14) using care to keep seal square with bore.
10. Fill exciter housing with exciter oil. Refer to Changing Exciter Oil, page 5. or proper procedure and amount.
11. Install drive gear coupler (# 16, page 14) if removed.
12. Install spiders and frame.

Parts Replacement Cycles and Tolerances

Bearings	Replace anytime a bearing is rough, binding, discolored or removed from housing or shaft.
Hardware	Replace any worn or damaged hardware as needed. Replacement hardware should be grade 5 and zinc plated unless otherwise specified.
Safety Decals	Replace if they become damaged or illegible.
Seals & Gaskets	Replace if a leak is detected and at every overhaul or tear down.

This page intentionally left blank.

REPLACEMENT PARTS

The warranty is stated in this book on page 14. Failure to return the Warranty Registration Card renders the warranty null and void.

Blue Diamond has established a network of reputable distributors/dealers with trained mechanics and full facilities for maintenance and rebuilding, and to carry an adequate parts stock in all areas of the country. Their sales engineers are available for professional consultation. If you cannot locate an Blue Diamond distributor in your area, contact Blue Diamond or one of our Sales Branches listed below.

When ordering replacement parts, be sure to have the following information available:

- Model and Serial Number of machine when ordering Blue Diamond parts
- Model and Serial Number of engine when ordering engine parts
- Part Number, Description, and Quantity
- Company Name, Address, Zip Code, and Purchase Order Number
- Preferred method of shipping

REMEMBER - You own the best! If repairs are needed, use only Blue Diamond parts purchased from authorized Blue Diamond distributors.

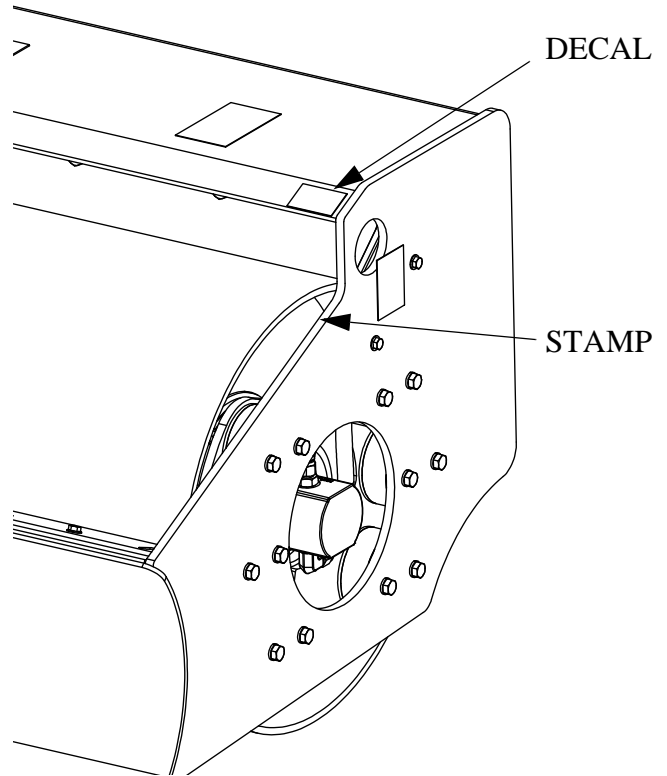

The unit's serial number can be found in the following locations:

- The model and serial number are on the top front of the roller frame
- The serial number is also stamped on the frame side

Write Model Number here

Write Serial Number here

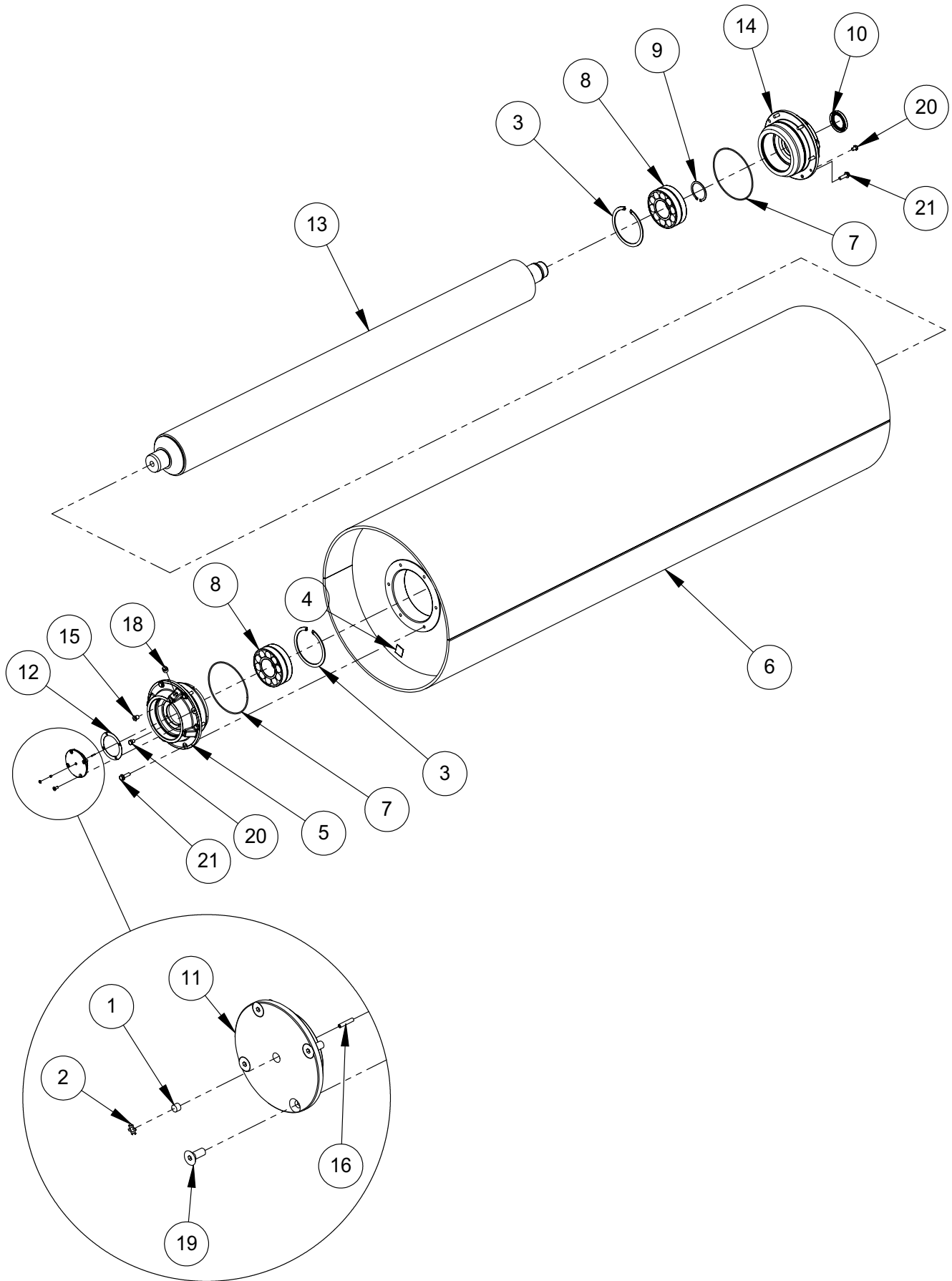

Drum Assembly

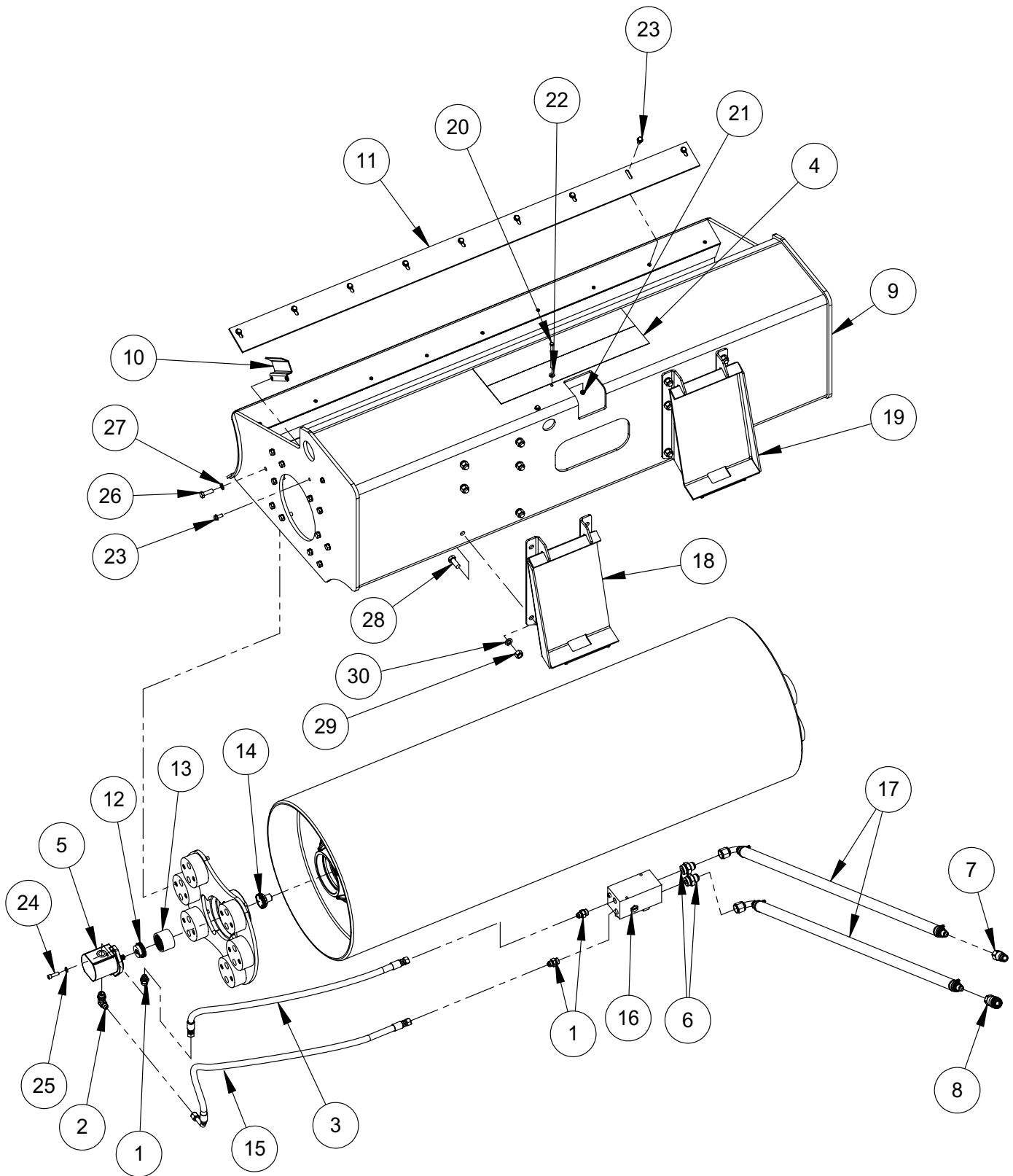

Main Assembly

ITEM	PART NO.	DESCRIPTION	ATP73	ATS73	ATP84	ATS84
1.	08213	FITTING, STRAIGHT	3	3	3	3
2.	08730	FITTING, ELBOW	1	1	1	1
3.	13166	HOSE, HYDRAULIC 1/2" X 47.00"	1	1	0	0
	17980	HOSE, HYDRAULIC 1/2" X 55.00"	0	0	1	1
4.	13984	SHEET, SAFETY WALK 24"	2	2	2	2
5.	14267	MOTOR, HYDRAULIC	1	1	1	1
6.	14747	FITTING, STRAIGHT	2	2	2	2
7.	17842	FLAT FACE COUPLING, MALE 1/2"	1	1	1	1
8.	17843	FLAT FACE COUPLING, FEMALE 1/2"	1	1	1	1
9.	21004	FRAME, AT73	1	1	0	0
	21005	FRAME, AT84	0	0	1	1
10.	17856	GAURD, HOSE	1	1	1	1
11.	17924	SCRAPER BAR ATP73 (PADDED)	1	0	0	0
	17894	SCRAPER BAR ATS73 (SMOOTH)	0	1	0	0
	17925	SCRAPER BAR ATP84 (PADDED)	0	0	1	0
	17895	SCRAPER BAR ATS84 (SMOOTH)	0	0	0	1
12.	17975	COUPLER, GEAR, 9T SPLINE	1	1	1	1
13.	17976	SLEEVE, COUPLER, GEAR	1	1	1	1
14.	17977	COUPLER, GEAR, 1"-12 THREAD	1	1	1	1
15.	17981	HOSE, HYDRAULIC 1/2" X 53.5"	1	1	0	0
	17979	HOSE, HYDRAULIC 1/2" X 59.00"	0	0	1	1
16.	18107	VALVE COMBINATION (.203 ORIFICE)	1	1	1	1
17.	18127	HOSE, HYDRAULIC 3/4" X 64.00"	2	2	2	2
18.	18656	BRACKET, LEFT	1	1	1	1
19.	18657	BRACKET, RIGHT	1	1	1	1
20.	F051836HCS	HEX HEAD CAP SCREW, 5/16"-18 X 4-1/2"	2	2	2	2
21.	F0518FN	NUT, FLANGE 5/16"-18	2	2	2	2
22.	F05SW	WASHER, 5/16" X 3/4" X 15GA	2	2	2	2
23.	F061607FWS	FLANGE HEAD CAP SCREW, 3/8"-16 X 7/8"	11	11	11	11
24.	F061610SCS	SOCKET HEAD CAP SCREW, 3/8"-16 X 1-1/4"	2	2	2	2
25.	F06LW	LOCKWASHER, 3/8"	2	2	2	2
26.	F081312HCS	HEX HEAD CAP SCREW, 1/2"-13 X 1-1/2"	24	24	24	24
27.	F08LW	LOCKWASHER, 1/2"	24	24	24	24
28.	F101112HCS	HEX HEAD CAP SCREW, 5/8"-11 X 1-1/2"	8	8	8	8
29.	F1011HN	NUT, HEX 5/8"-11	8	8	8	8
30.	F10LW	LOCKWASHER, 5/8"	8	8	8	8
	17994	<u>NOT SHOWN</u> SEAL KIT FOR 14267 HYDRAULIC MOTOR	1	1	1	1

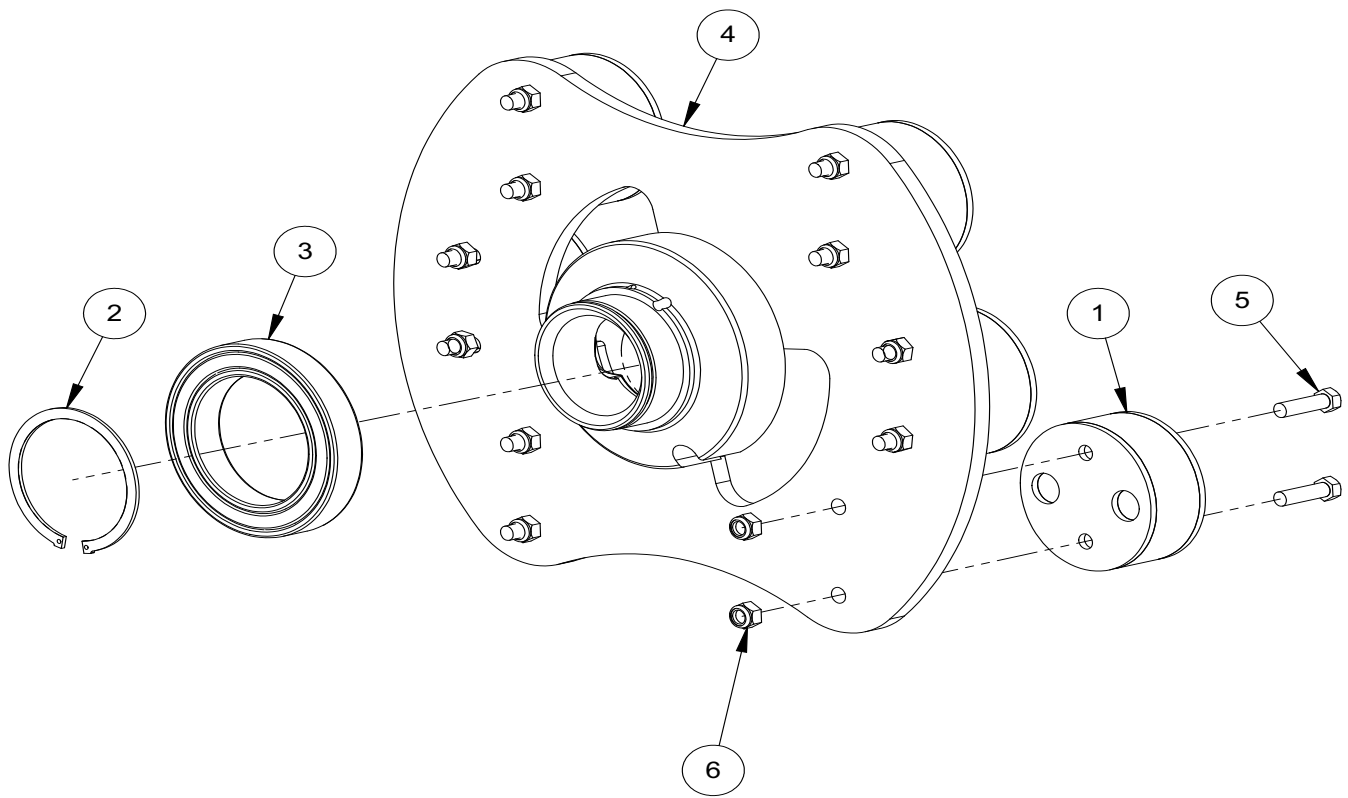

Spider Assembly

WARRANTY

Manufacturer's Limited Warranty

BLUE DIAMOND ATTACHMENTS, a manufacturer of quality attachments, warrants new BLUE DIAMOND ATTACHMENTS products and/or attachments at the time of delivery to the original purchaser, to be free from defects in material and workmanship when properly set up and operated in accordance with the recommendations set forth by BLUE DIAMOND ATTACHMENTS, LLC.

BLUE DIAMOND ATTACHMENTS liability for any defect with respect to accepted goods shall be limited to repairing the goods at an BLUE DIAMOND ATTACHMENTS designated location or at an authorized dealer location, or replacing them, as BLUE DIAMOND ATTACHMENTS shall elect. The above shall be in accordance with BLUE DIAMOND ATTACHMENTS warranty adjustment policies. BLUE DIAMOND ATTACHMENTS obligation shall terminate twenty-four (24) months for the Extreme Brush Cutter and twelve (12) months for the Standard Duty Brush Cutter after the delivery of the goods to original purchaser.

This warranty shall not apply to any machine or attachment which shall have been repaired or altered outside the BLUE DIAMOND ATTACHMENTS factory or authorized BLUE DIAMOND ATTACHMENTS dealership or in any way so as in BLUE DIAMOND ATTACHMENTS judgment, to affect its stability or reliability, nor which has been subject to misuse, negligence or accident beyond the Company recommended machine rated capacity.

Warranty Claim

To submit a warranty claim, a return authorization from BLUE DIAMOND ATTACHMENTS must be obtained. The failed part may then be returned. Tampering with the failed part may void the warranty. This warranty does not include freight or delivery charges incurred when returning machinery for servicing. Dealer mileage, service calls, and pickup/delivery charges are the customers' responsibility.

Exclusions of Warranty

Except as otherwise expressly stated herein, BLUE DIAMOND ATTACHMENTS makes no representation or warranty of any kind, expressed or implied, AND MAKES NO WARRANTY OF MERCHANTABILITY IN RESPECT TO ITS MACHINERY AND/OR ATTACHMENTS ARE FIT FOR ANY PARTICULAR PURPOSE. BLUE DIAMOND ATTACHMENTS shall not be liable for incidental or consequential damages for any breach or warranty, including but not limited to inconvenience, rental of replacement equipment, loss of profits or other commercial loss. Upon purchase, the buyer assumes all liability for all personal injury and property resulting from the handling, possession, or use of the goods by the buyer.

No agent, employee, or representative of BLUE DIAMOND ATTACHMENTS has any authority to bind BLUE DIAMOND ATTACHMENTS, LLC. to any affirmation, representation, or

warranty concerning its machinery and/or attachments except as specifically set forth herein.

This warranty policy supersedes any previous documents. Blue Diamond Attachments, a manufacturer of quality attachments, warrants new Blue Diamond Attachments products and/or attachments at the time of delivery to the original purchaser, to be free from defects in material and workmanship when properly set up and operated in accordance with the recommendations set forth by Blue Diamond Attachments, LLC. *To file a warranty claim, please contact your nearest Blue Diamond Dealer or sales representative.*

Brush Cutters:

The Blue Diamond Brush Cutters have a two(2) year warranty policy: one year on parts and labor, and the second year on parts only. Dis-assembly of the cutter in any way, including the blade carrier, housing components, and/or motor, may void the warranty. Please contact Blue Diamond Attachments for instructions and authorization before taking apart to verify warranty.

Augers:

Warranty coverage on Blue Diamond Auger attachments is four(4) years on the Heavy Duty Series, and six(6) years on the Extreme Duty. Bent or Broken auger shafts are void from warranty. Coverage may be refused by Blue Diamond Attachments if the unit appears to have been abused or misused.

Pallet Forks:

Blue Diamond Pallet Forks have a one(1) year warranty. If the forks are put in an application where the weight that is lifted exceeds the fork rating, all warranty coverage will be voided.

Grapples:

All Grapples manufactured by Blue Diamond Attachments have a one(1) year warranty. Faulty cylinders are covered by warranty. Bent tines and/or bent hydraulic cylinders are not covered nor implied by warranty.

Thumbs:

Blue Diamond Thumbs have a one(1) year warranty on manufacturing defects, including weld cracks and leaking cylinders. Bent cylinders and/or bent tines/frame are not covered by warranty.

Other Attachments:

All other attachments that are not listed above, have a one(1) year warranty. This covers any manufacturing defect. Bent tines and/or bent cylinders are not covered. Any modification or alteration in any way may void the warranty on any piece. Blue Diamond Attachments, LLC reserves the right to decline any warranty claim at their digression.



QUALITY | DEPENDABILITY | INTEGRITY

Blue Diamond® Attachments
4512 Anderson Road, Knoxville, TN 37918
888-376-7027