

Mini Snow Blower

Operation and Maintenance Manual



Register your
WARRANTY
within 30 days
of purchase



888-376-7027 | BlueDiamondAttachments.com



BD-092

Introduction: Owner Information

Thank you for your decision to purchase a Blue Diamond® Mini Snow Blower. To ensure maximum performance of your equipment, it is mandatory that you thoroughly study the Operator's manual and follow the recommendations. Proper operation and maintenance are essential to maximize equipment life and prevent personal injury.

Operate and maintain this equipment in a safe manner and in accordance with all applicable local, state, and federal codes, regulations and /or laws. Follow all on-product labeling and instructions.

Make sure that all personnel have read this Operator's Manual and thoroughly understand safe and correct operating, installation and maintenance procedures.

Blue Diamond is continually working to improve its products. Blue Diamond reserves the right to make any improvements or changes as deemed practical and possible without incurring any responsibility or obligation to make any changes or additions to equipment sold previously.

Although great care has been taken to ensure the accuracy of this publication, Blue Diamond makes no warranty or guarantee of any kind, written or expressed, implied or otherwise with regard to the information contained within this manual. Blue Diamond assumes no responsibility for any errors that may appear in this manual and shall not be liable under any circumstances for incidental, consequential or punitive damages in connection with, or arising from the use of this manual.

Keep this manual available for frequent reference. All new operators or owners must review the manual before using the equipment and annually thereafter. Contact your Blue Diamond Attachments Dealer for assistance, information, or additional copies of the manual. Contact www.bluediamondattachments.com or call 888-376-7027 for a complete list of dealers in your area.

Serial Number Location:

Please record attachment information in the space provided for future reference.

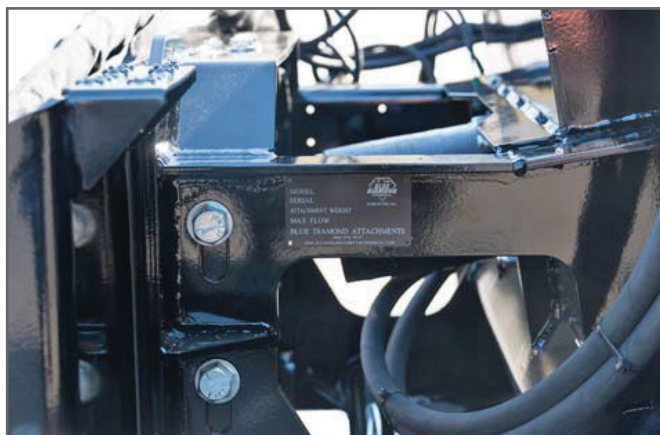

Model Number: _____

Serial Number: _____

Dealer Name: _____

Dealer Number: _____

Date of Purchase: _____

The serial number plate is located on the right side of the frame.

Always use your serial number when requesting information or when ordering parts.

NOTE: The directions left, right, front and rear, as mentioned throughout this manual, are as viewed from the operator's position.

Table of Contents

1. Introduction.....	4-5
1.1 Attachment Identification	4
1.2 Attachment Specifications	5
2. Safety	6-12
2.1 General Safety Information.....	6
2.2 Qualified Operators.....	7
2.3 Equipment Safety Instructions.....	7
2.4 Operating Safety Instructions	8
2.5 Transporting Safety Instructions.....	9
2.6 Maintenance Safety Instructions.....	10
2.7 Storage Safety Instructions.....	10
2.8 Safety Decals.....	11
3. Set Up	13-16
3.1 General Information.....	13
3.2 Connecting to the Tractor	15
3.3 Driveline Installation.....	15
3.4 Tractor–Tiller Stability	16
4. Operation	17-21
4.1 Start Up.....	16
4.2 Operation Instructions	18
4.3 Adjustments	19
4.4 Stopping and Disconnecting.....	21
4.5 Transporting.....	21
5. Maintenance.....	22-26
5.1 Blades Replacement	22
5.2 Gearbox Lubrication.....	24
5.3 Side Case Lubrication.....	24
5.4 Bearing Housing Lubrication.....	25
5.5 Driveshaft Maintenance	25
6. Storage	27
7. Scrapping.....	28
8. Troubleshooting.....	29-30
9. Specifications	31
9.1 Torque Specifications.....	31
10. Spare Parts	32
11. Parts.....	33-39
11.1 LH Side Plate Components	33
11.2 RH Side Plate Components	34
11.3 Main Frame Components.....	35
11.4 Top Gearbox Components	38
11.5 Slipclutch Driveline Components – 4’, 5’, & 6’ Tillers... 39	
11. Warranty.....	41

1. Introduction

1.1 Attachment Identification

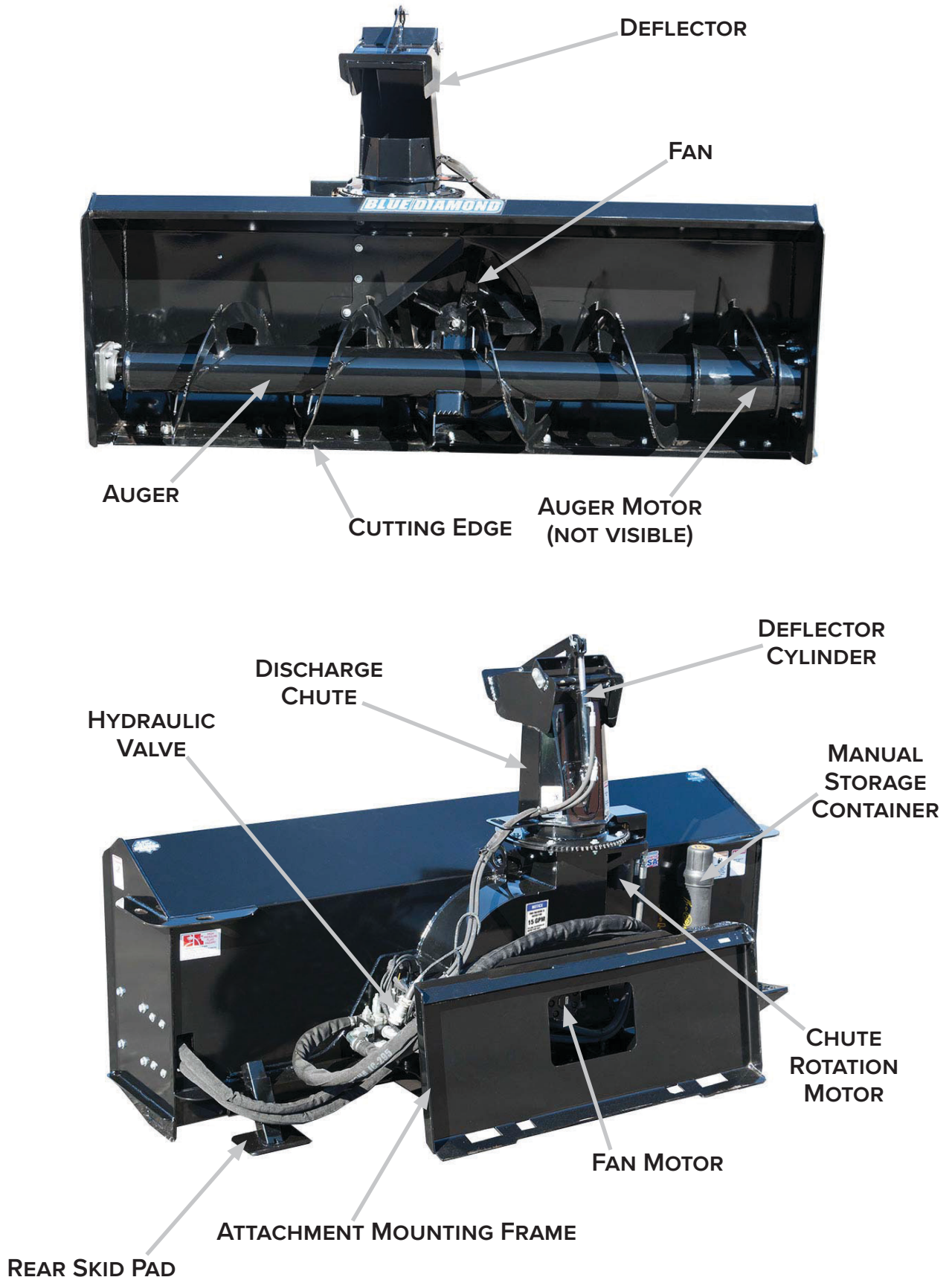

1. Introduction

1.2 Attachment Model Numbers

MINI SNOW BLOWER	MODEL NUMBER
48"	
54"	
60"	
63"	

1.3 Standard Items

- Hydraulic Chute Deflector
- Hydraulic Chute Rotation, 270° (with 7.19" opening)
- Bolt-on Cutting Edge
- Ribbon Saw Teeth Augers
- Single auger with 4" center tube and 16" diameter X 7 gauge flighting
- 4 bolt auger bearings accommodate 1.5" diameter shaft
- Adjustable Rear Skid Shoes
- Removeable Quick-Tach Mounting
- Universal Control Harness
- All hydraulic motors (fan motor, enclosed auger motor, chute motor, and deflector cylinder)
- Two-stage Design with 6.5" X 18" 4 Paddle Fan
- Independent Fan and Auger Bypass Relief (no shear pins)
- Powder Coated Paint

1.4 Options

- Various hydraulic packages to match the GPM of most skid steers
- Various electrical harnesses to fit most skid steer models

1.5 Manual Storage

The manual storage container (Item 1) [Figure 1] is located on the left rear of the snow blower frame.

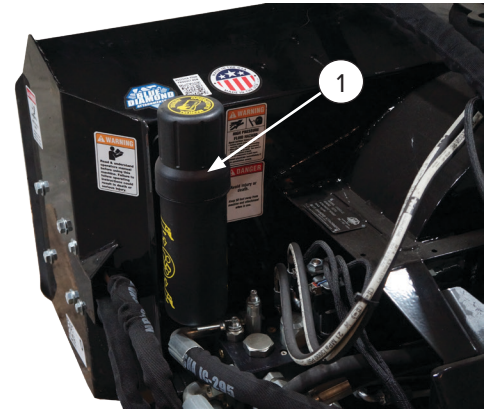

Figure 1

2. Safety

2.1 General Safety Information



This **SAFETY ALERT SYMBOL** identifies important safety messages on the equipment and in the owner's manual. When you see this symbol, be alert to the possibility of personal injury and carefully read the message that follows.



The signal word **IMPORTANT** identifies procedures which must be followed to avoid damage to the machine.



The signal word **DANGER** on the machine and in the manuals indicates a hazardous situation which, if not avoided, will result in death or serious injury.



The signal word **WARNING** on the machine and in the manuals indicates a potentially hazardous situation which, if not avoided, could result in death or serious injury.



The signal word **CAUTION** on the machine and in the manuals indicates a potentially hazardous situation which, if not avoided, may result in minor or moderate injury. It may also be used to alert against unsafe practices.

NOTE: Notes are used to indicate important information. This information may be repeated in other areas of the manual.

Operating Safety

- Read and follow instructions in this manual and the machine's Operators Manual before operating.
- The manual must always remain with the machine. In case of loss or damage, request a new copy from your dealer or from Blue Diamond.
- Strictly follow all rules prescribed by the safety pictograms/decals applied to the machine. Ensure that all safety pictograms/decals are legible. If pictograms/decals are worn, they must be replaced with new ones obtained from Blue Diamond and placed in the position indicated by this manual.
- Before using the machine, make sure that all safety devices are installed and in good working conditions. In case of damage or shields, replace them immediately.
- It is absolutely forbidden to remove or alter safety devices and/or safety precautions
- Pay maximum attention to avoid any accidental contact with rotating parts of the machine.
- If the use of the machine is required at night or in conditions of reduced visibility, use the lighting system of the prime mover and possibly an auxiliary lighting system.

2. Safety



2.2 Operators

Qualified Operators

The operator is a person suited to the work and who is physically and psychologically able to withstand the demands connected with operating the equipment for its intended use. The operator must not allow anyone to approach the machine while it is working and must not allow external personnel to operate the machine or attachment.

He is to follow the given instructions in this manual and the machine operator's manual in order to obtain maximum performance, minimum consumption, and maximum safety for himself and for others.

The operator is responsible for scrupulously observing all the instructions given in this manual.

 **DANGER** 

AVOID SERIOUS INJURY OR DEATH

Operators must receive instructions before operating the machine. Untrained operators can cause serious injury or death.

For an operator to be qualified, he or she must not use drugs or alcoholic drinks which impair alertness or coordination while working. An operator who is taking prescription drugs must get medical advice to determine if he or she can safely operate a machine and the equipment.

For an operator to be qualified, he or she must have read and understood the instructions of this manual, he or she must make adequate preparation for the proper use of the machine, and he or she must hold a driving license.

In case of doubt regarding the use of the machine and/or the interpretation of this manual, the operator must contact either their dealer or Blue Diamond.

Operator Training

- Check the rules and regulations at your location. The rules may include an employer's work safety requirements. Regulations may apply to local driving requirements or use of a Slow Moving Vehicle (SMV) emblem. Regulations may identify a hazard such as a utility line.
- The new operator must start in an area without bystanders and use all the controls until he or she can operate the machine safely under all conditions of the work area.

Operator Safety

- Before starting, and during operation of the attachment, make sure there are no people or animals in the operation area; the machine can project material from the back with risks of serious injury or death.
- During operation, adjustment, maintenance, repairing, or transportation of the machine, the operator must always use appropriate Personal Protective Equipment (PPE) including but not limited to safety glasses, working gloves, dust-mask, safety helmet, and hearing protection.
- Do not operate the attachment or machine while wearing loose fitting clothing that can be entangled or caught in parts of the machine.
- Do not operate the implement when tired, not in good condition, or under the influence of alcohol or drugs.

2. Safety

2.3 Safety Guidelines

Operating Safety

- Read and follow instructions in this manual and the machine's Operator's Manual before operating.
- This equipment is dangerous to persons unfamiliar with its operation.
- Check for overhead and / or underground lines before operating equipment (if applicable).
- In addition to the design and configuration of equipment, hazard control and accident prevention are dependent upon the awareness, concern, prudence and proper training of personnel involved in the operation, transport, maintenance and storage of equipment.
- Check that the attachment is securely fastened to the machine.
- Make sure all the machine controls are in NEUTRAL before starting the machine.
- Operate the equipment only from the operator's position.
- Operate the equipment according to the Operator's Manual.
- When learning to operate the equipment, do it at a slow rate in an area clear of bystanders.
- DO NOT permit personnel to be in the work area when operating the equipment.
- The equipment must be used ONLY on approved machines.
- DO NOT modify the equipment in any way. Unauthorized modification may impair the function and / or safety and could affect the life of the equipment. Affect or void warranty too.
- DO NOT make any adjustments or repairs on the equipment while the machine is running.
- Keep shields and guards in place. Replace if damaged.
- NEVER run objects other than snow and ice through the snow blower.
- DO NOT operate equipment in poor visibility conditions such as fog, darkness, or any conditions that limit clear visibility less than 300 feet (100 m) in front of and to the sides of the equipment.
- When conditions make it necessary to slow ground speed, shift to a lower gear rather than reducing engine speed. The engine will maintain rated speed and keep the snow blower running at optimum speed.
- DO NOT operate in a work area that has not been inspected for foreign debris and obstacles.
- Remove any foreign objects and clearly mark any objects that cannot be removed.
- Wear safety glasses, gloves, hearing protection and other protective clothing when required.

2. Safety

Fire Prevention Safety

- Flammable debris (leaves, grass, etc.) must be removed regularly. If flammable debris is allowed to accumulate, it can cause a fire hazard. Clean often to avoid this accumulation.
- The equipment's hydraulic motor compartment must be inspected every day and cleaned if necessary to prevent fire hazards and overheating.
- All fuels, most lubricants, and some coolant mixtures are flammable. Flammable fluids that are leaking or spilled onto hot surfaces or onto electrical components can cause a fire.

Transporting Safety

- Comply with state and local laws governing highway safety and movement of machinery on public roads.
- Check local laws for all highway lighting and marking requirements.
- Always yield to oncoming traffic and move to the side of the road so any following traffic may pass.
- Never allow riders on either machine or equipment.
- If transporting the equipment on a truck or trailer, make sure the equipment is properly secured to the transport vehicle.

Hydraulic System

- Check hydraulic tubes, hoses and fittings for damage and leakage. Never use open flame or bare skin to check for leaks. Hydraulic tubes and hoses must be properly routed and have adequate support and secure clamps. Tighten or replace any parts that show leakage.
- Always clean fluid spills. Do not use gasoline or diesel fuel for cleaning parts. Use commercial nonflammable solvents.

Personal Protective Equipment

When operating the snow blower, be sure that you are dressed appropriate for the weather. Cold weather can be very dangerous. Be sure that your workclothes are rated properly for the temperature in addition to fitting the requirements below.



Proper Workclothes: To help ensure your safety as a designated operator wear proper workclothes including tight fitting clothes, protective gloves and shoes.



Hand Protection: To help ensure your safety as a designated operator wear protective gloves.



Protective Shoes: To help ensure your safety as a designated operator wear protective shoes.



Safety Helmet: To help ensure your safety as a designated operator wear a safety helmet.



Safety Helmet and Eye/Ear Protection: To help ensure your safety as a designated operator wear a safety helmet and eye/ear protection.

3. Operation

3.1 Pre-Operation Inspection

Before operating the snow blower for the first time and each time thereafter, use the following list as a guideline during equipment inspection.



WARNING



AVOID SERIOUS INJURY OR DEATH

- Disengage machine's auxiliary hydraulics, engage the machine's parking brake, stop the engine, and make sure all rotating components are completely stopped before connecting, disconnecting, adjusting, or cleaning equipment.
- Always keep shields and all guards in place when using the equipment.
- Disengage machine's auxiliary hydraulics for road travel.
- Keep hands, feet, and clothing away from rotating parts.

- Use only a machine of adequate power and weight to operate the snow blower.
- Fully clean the attachment. (See section X.X Cleaning the Attachment" on page XX.)
- Lubricate the attachment per the schedule outline in the Maintenance Section (See section X.X Grease Points on page XX.)
- Check the snow blower mounting plate for wear or damage.
- Check the fan, auger, and cutting edge for entangled debris, wear, or damage.
- Check that all shields and guards are in place.
- Check for loose bolts and tighten them if necessary.
- Check all welds on the attachment for cracks each time the attachment is removed from the machine.
- Check for damaged or missing safety decals. Replace if necessary.

- Inspect the machine's mounting frame. (See the machine's Operator's Manual for inspecting the mounting frame). Replace any parts that are damaged, bent, or missing. Keep all fasteners tight. Look for cracked welds.



WARNING



Leaking fluids under pressure can enter the skin and cause serious injury or death. Immediate medical attention is required. Wear goggles. Use cardboard to check for leaks.

- Check that the chute rotation gear is fully engaged and not worn. Adjust or repair as needed before operation.
 - Check that all wire harness connections are secure.
 - Check condition of all hydraulic components for leaks. Repair as required.
- NOTE:** Do not operate with hydraulic leaks.
- Verify that the snow blower is properly connected to the machine.

3. Operation

3.2 Attachment Inspection

Daily Inspection

NOTE: Inspect the attachment by performing a walk around daily before and after use. Use the following inspection checklist as a guideline.

Check the following items every 10 hours of operation:

	EVERY 10 HOURS
✓	Verify that the snow blower is properly connected to the machine.
✓	Check that all shields and guards are in place.
✓	Check for damaged or leaking hydraulic hoses or fitting. Replace if necessary.
✓	Check the snow blower mounting hardware for wear or damage. Inspect the pins and mount (on the attachment) for wear or damage. Repair or replace damaged parts if necessary.

Weekly Inspection

Check the following items every 40 hours of operation:

	EVERY 40 HOURS
✓	Check the cutting edge for wear or damage.
✓	Inspect the snow blower fan and auger for cracks, bends, or damage.
✓	Check the discharge chute and deflector for wear or damage.
✓	Check all bolts for tightness.

Replace any worn or damaged parts.

Monthly Inspection

	EVERY 10 HOURS
✓	Inspect the snow blower frame and all welds for cracks or damage.
✓	Check skid plates for wear.
✓	Check that all bolts are tight.
✓	Check for damaged or missing decals. Replace if necessary.

3.3 Machine Requirements

SNOW BLOWER MODEL	HYDRAULIC FLOW	LIFT CAPACITY
48"	8 – 25 GPM	420 lbs
54"	8 – 25 GPM	430 lbs
60"	8 – 25 GPM	440 lbs
63"	8 – 25 GPM	450 lbs

HYDRAULIC FLOW OPTIONS	
HYDRAULIC PACKAGE	SKID STEER REQUIREMENTS
8	7 – 9 GPM
12	10 – 13 GPM
15	14 – 18 GPM
20	19 – 25 GPM

3. Operation

3.3 Machine Requirements Cont'd

Machine Hydraulic Rating

! IMPORTANT !

The snow blower is rated for a specific hydraulic flow that should match your machine hydraulic capacity. Operating the snow blower at a higher than rated flow will over-speed the snow blower and may cause severe damage to snow blower components, and will void your product warranty.



Figure 2

NOTICE

**THIS MACHINE IS
RATED FOR
8 GPM**

**FAILURE TO OPERATE AT
RATED FLOW MAY:**

- RESULT IN POOR PERFORMANCE
- LEAD TO MECHANICAL FAILURE
- VOID MACHINE WARRANTY

NOTICE

**THIS MACHINE IS
RATED FOR
12 GPM**

**FAILURE TO OPERATE AT
RATED FLOW MAY:**

- RESULT IN POOR PERFORMANCE
- LEAD TO MECHANICAL FAILURE
- VOID MACHINE WARRANTY

NOTICE

**THIS MACHINE IS
RATED FOR
15 GPM**

**FAILURE TO OPERATE AT
RATED FLOW MAY:**

- RESULT IN POOR PERFORMANCE
- LEAD TO MECHANICAL FAILURE
- VOID MACHINE WARRANTY

NOTICE

**THIS MACHINE IS
RATED FOR
20 GPM**

**FAILURE TO OPERATE AT
RATED FLOW MAY:**

- RESULT IN POOR PERFORMANCE
- LEAD TO MECHANICAL FAILURE
- VOID MACHINE WARRANTY

Locate the snow blower hydraulic flow rating decal (Item 1) [Figure 2] and ensure that the machine is rated for the required flow. Set the operator controls to match the rated flow of the snow blower. Do not operate at flow setting higher than the rated flow. Do not use a machine that is not rated for the required snow blower hydraulic flow.

3. Operation

3.4 Attachment Installation

IMPORTANT



See the machine's Operator's Manual for detailed information on operating the loader.

Entering The Operator's Position

Use the attachment safety treads, handles and steps (on the machine) to enter the operator's position.

When in the operator's position, lower safety seat bar, start the engine and release the parking brake.

Leaving The Operator's Position

WARNING

AVOID SERIOUS INJURY OR DEATH

- Always park on a flat level surface.
- Lower lift arms and place attachment flat on the ground.
- Place all controls in **NEUTRAL**.
- Engage the park brake.
- Stop the engine and remove the key.
- Wait for all moving parts to stop.

SEE MACHINE'S OPERATOR'S MANUAL FOR ADDITIONAL INFORMATION.

Place all controls in neutral, engage the park brake, stop the engine and wait for all moving parts to stop. Leave the operator's position.

Connecting Attachment To The Machine

WARNING



CRUSH HAZARD

- Before moving the machine, look in all directions and make sure no bystanders, especially small children are in the work area. Do not allow anyone between the machine and attachment when approaching the attachment for connecting.
- Keep fingers and hands out of pinch points when connecting and disconnecting the attachment.

Before connecting to the attachment, inspect the machine's mounting plate. (See the machine's Operator's Manual for inspecting the mounting frame).

Enter the operator's position. (See "Entering The Operator's Position" on page 13.)

Drive the machine slowly forward, until the top edge of the machine's mounting plate is under the top flange of the attachment mounting frame.

Slowly tilt the machine's mounting plate back until the attachment mounting frame fully contacts the front of the machine's mounting plate.

Leave the operator's position. (See "Leaving The Operator's Position" on page 13.)

Stop the engine and engage the parking brake.

Leave the operator's position. (See "Leaving the Operator's Position" on page 13.)

Engage attachment locking levers / wedges (See the machine's Operator's Manual for detailed information.)

Visually inspect that the wedge pins are securely fastened into the snow blower mounting frame.

3. Operation

Connecting Attachment to the Machine Cont'd



WARNING



AVOID SERIOUS INJURY OR DEATH

The locking pins / wedges must extend through the holes in the attachment mounting frame. Failure to secure locking pins / wedges can allow attachment to come off.

SEE MACHINE'S OPERATOR'S MANUAL FOR ADDITIONAL INFORMATION.

Connecting Hydraulic Hoses



IMPORTANT



Thoroughly clean the quick couplers before making connections. Dirt can quickly damage the hydraulic system.

Remove dirt or debris from the male and female couplers. Visually inspect the couplers for corroding, cracking, damage, or excessive wear. Replace as needed.

Connect the attachment hydraulic hoses to the machine. Pull on each hose to verify full connection is made.

Disconnecting Hydraulic Hoses



WARNING



AVOID SERIOUS INJURY OR DEATH

Hydraulic fluid, tubes, fittings, and quick couplers can get hot during operation. Be careful when connecting and disconnecting hydraulic hoses.

Relieve auxiliary hydraulic pressure. (See the machine's Operator's Manual for correct procedure.)

Disconnect attachment hydraulic hoses from the machine.

Attachment Control Harness

Connecting Attachment Control Harness

Remove storage cap on the machine and snowblower control harness ends. Route and connect the snow blower's attachment control harness to the machine attachment control connector bulkhead. Secure harness to route with existing snowblower hoses.

Disconnecting Attachment Control Harness

Disconnect the snow blower attachment control harness from the attachment control connector bulkhead. Replace storage caps on the bulkhead and snow blower connector ends.

Disconnecting Attachment From the Machine

Relieve auxiliary hydraulic pressure. (See the machine's Operator's Manual for correct procedure.)

Park the machine and attachment on a flat level surface. Lower the attachment flat on the ground.

Leave the operator's position. See "Leaving the Operator's Position" on page 13.

Disconnect attachment hydraulic hoses from the machine.

Disengage locking pins / wedges. (See the machine's Operator's Manual for correct procedure.)

Enter the operator's position. See "Entering the Operator's Position" on page 13.

Slowly tilt the machine's mounting plate forward until the attachment mounting frame is free from the machine's mounting plate.

Drive the machine slowly backward, away from the attachment.

3. Operation

3.5 Operating the Attachment

Checking the Snow Blower Hydraulic Functions

NOTE: After installing the snow blower, test all snow blower functions before operating the snow blower in the work area.



WARNING



AVOID SERIOUS INJURY OR DEATH

- Never start the machine from outside the cab.
- Never operate the machine if any safety device is damaged, disconnected, or missing.
- Never exit the machine with the engine running.



WARNING



AVOID SERIOUS INJURY OR DEATH

While operating the machine:

- Always keep seat belt fastened.
- Safety seat bar lowered (if equipped).
- Always keep your feet on the pedals or footrests and hands on the controls.



IMPORTANT



It is the operator's responsibility to know which machine control operates each function of the attachment prior to operating the attachment in the work area.

Enter the machine. (See "Entering the Operator's Position" on page 13.)

Start the engine and release the parking brake.



IMPORTANT



When engaging or disengaging the snow blower hydraulics, the machine must be at idle. Hydraulic motor damage will occur if this procedure is not followed, voiding warranty.

Engage the machine's auxiliary hydraulics. (See the machine's Operation Manual for correct procedure.)

Raise the engine RPM.

Auger and Fan Rotation

Start auger / fan rotation. Allow the snow blower auger and fan to rotate for a short time (approximately one minute).

NOTE: When cold starting, allow hydraulic temperature to reach a minimum of 60°F.



IMPORTANT



The snow blower fan and auger motors require a break-in period prior to putting the snow blower into service. Hydraulic motor damage will occur if this procedure is not followed, voiding warranty.

If operating the snow blower for the first time, operate the fan and auger at a low speed for a break-in period of approximately 20 minutes. It is important to follow this procedure as break-in period may not have been reached during initial factory run-out.

Chute Rotation

Raise the engine RPM.

Rotate the discharge chute in both directions. The discharge chute should rotate freely.

Deflector Raise / Lower

Raise and lower the deflector multiple times. The deflector should move up and down freely.

Lower engine RPM.

Disengage the machine's auxiliary hydraulics.

Slightly raise the snow blower.

Exit the machine. (See "Leaving the Operator's Position" on page 13.)

Adjust rear skid pads to desired height. (See "Rear Skid Pad Adjustment" on page 23).

NOTE: All rear skid pads must be set to the same height.

3. Operation

3.5 Operating the Attachment Cont'd

Final Snow Blower Adjustments

Ensure pressure and return hydraulic lines and the snow blower control harness are both routed clear of any loader arm pinch points and are not dragging on the ground. Protect hose and harness from sharp edges on the machine.

Check the machine flow rating on page 11 and ensure machine settings are correct for proper hydraulic flow (See “Machine Requirements” on page 11.)

Set all machine control functions for optimum performance. (See “Machine Controls”)

Move the machine and snow blower to the work area.

Operation

Move the machine and snow blower to the work area.



WARNING



AVOID SERIOUS INJURY OR DEATH

Warnings on the machine and in the manuals are for your safety. Failure to obey warnings can cause serious injury or death.



WARNING



AVOID SERIOUS INJURY OR DEATH

- Check for overhead power lines and other overhead obstructions before operating the snow blower in a raised position.
- Keep the snow blower a minimum of 10 ft away from electrical power lines.



WARNING



AVOID SERIOUS INJURY OR DEATH

While operating the machine:

- Always keep seat belt fastened.
- Safety seat bar lowered (if equipped).
- Make sure that there are no personnel on the machine or in the area around the machine.
- Engage the park brake.
- Only operate the machine while sitting in the operator's position.
- Always keep your feet on the pedals or footrests and hands on the controls.
- Only operate the controls when the engine is running.



WARNING



THROWN OBJECTS CAN CAUSE SERIOUS INJURY OR DEATH

- Clear work area of all debris, such as rope, wire, cable or other materials that can wrap around auger causing entanglement and attachment damage.
- Never direct discharge toward bystanders, buildings, or other property. Debris can be thrown great distances.

Make sure the skid pads are adjusted to the same height (see “Rear Skid Pad Adjustment” on page 23).

Make certain snow blower setup is correct and ready for operation (see “Final Snow Blower Adjustments” on page 16).

Enter the machine (see “Entering the Operator's Position” on page 13).

Start the engine and release the parking brake.

Engage the machine's auxiliary hydraulics (see the machine's Operation Manual for correct procedure).

3. Operation

3.5 Operating the Attachment Cont'd

Operation Cont'd



When engaging or disengaging the snow blower hydraulics, the machine must be at idle. Hydraulic motor damage will occur if this procedure is not followed, voiding warranty.

Move the engine speed control to high RPM.
Rotate the discharge chute to the desired position.



AVOID SERIOUS INJURY OR DEATH

Never direct discharge toward bystanders, buildings, or other property. Debris can be thrown great distances.

NOTE: Do not position the discharge chute so snow is thrown towards bystanders, vehicles, buildings, livestock, or roadways.

Adjust the deflector to control the distance the snow is thrown.

Move the machine engine speed control to high RPM.

NOTE: Use the Full Flow (auxiliary hydraulics at 100%) and High Performance (full rated engine RPM) modes on the machine control settings. Ensure that the machine auxiliary flow controls are set to match the snow blower flow rating limits (see "Machine Requirements" on page 11).

Recommendations

Place the machine arms in the float position (if desired).

Using the tilt function of the machine, position the snow blower to the desired working position.

Position the snow blower on the cutting edge when removing snow from paved / finished surfaces.

Position the snow blower on the skid pad when removing snow from graveled / unfinished surfaces.

NOTE: The machine speed is determined by the depth and density of the snow.

Work and Travel Speed

Working ground speed will depend upon the depth and density of the snow. Adjust speed as needed to clear the work area.

NOTE: A definite pattern of operation is required to thoroughly clean the work area. The following patterns will aid the operator and avoid throwing snow in unwanted areas of the work area.

Left or Right Discharge

Working ground speed will depend upon the depth and density of the snow. Adjust speed as needed to clear the work area.

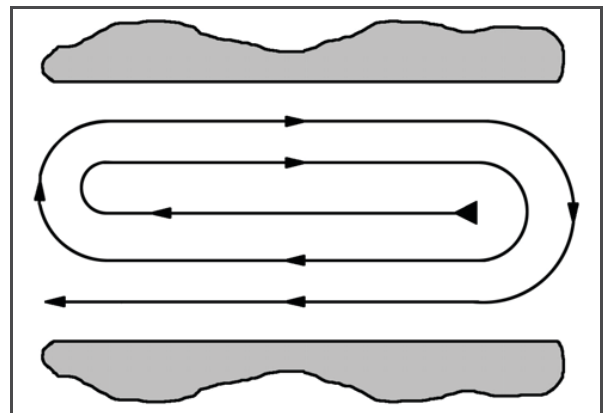

Figure 3

Where it is possible to throw the snow to the left and right sides of the work area, move the machine and snow blower to the center of the work area [Figure 3].

Move the machine and snow blower forward, from one end to the other, blowing snow to either side without changing the direction of the discharge chute [Figure 3].

3. Operation

3.5 Operating the Attachment Cont'd

Recommendations Cont'd

Single Sided Discharge

Working ground speed will depend upon the depth and density of the snow. Adjust speed as needed to clear the work area.

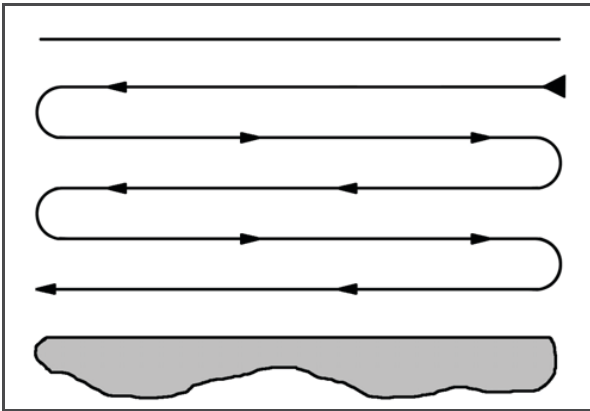

Figure 4

Where snow can only be thrown to one side, move the machine and snow blower to the opposite end of the work area, away from the area the snow will be thrown [Figure 4].

Move the machine and snow blower forward. At the end of the first path, rotate the discharge chute 180° to maintain direction the snow needs to be thrown. Rotate the discharge chute 180° at each end of the work area until desired amount of snow has been cleared [Figure 4].



DO NOT use the snow blower as a push bucket or push blade. Always have the auger and fan running when engaged in snow contact.

Clearing a Snow Bank

Working ground speed will depend upon the depth and density of the snow. Adjust speed as needed to clear the work area.



WARNING



AVOID SERIOUS INJURY OR DEATH

- Check for overhead power lines and other overhead obstructions before operating the snow blower in a raised position.
- Keep the snow blower a minimum of 10 ft away from electrical power lines.

If snow is deeper than the height of the snow blower housing, it is necessary to make multiple passes at different heights to clear the snow.

NOTE: Do not attempt to clear snow banks that are more than 6 feet in height.

Raise the snow blower to the desired height. Using the tilt function of the machine, position the snow blower parallel to the ground.

NOTE: Do not make a cut that is deeper than the height of the snow blower housing. Snow that pushes over the top of the snow blower housing can cause damage to hydraulic and electrical components.

Slowly drive forward until the front wheels / tracks of the machine contact the snow bank.

Back the machine up and adjust the blower to desired height and repeat procedure until the snow bank has been cleared or cut to desired height.

NOTE: Always allow auger and fan to clear of snow before changing the working height of the snow blower. Changing the height of the snow blower by moving the machine lift arms will slow the fan and auger speeds, which may cause the discharge chute to plug (see "Clearing a Plugged Snow Blower" on page 19).

3. Operation

3.5 Operating the Attachment Cont'd

Clearing a Plugged Snow Blower

Prevent Plugging the Snow Blower



Proper operation and use of the snow blower will prevent plugging the auger, fan, and discharge chute.

- Operating at too high of a travel speed for current conditions may overload the auger and slow the fan speed, causing snow to bridge and not fully clear the discharge chute.
- Using the loader arms while the snow blower is engaged in snow will also slow the fan speed, causing snow to bridge and not fully clear the discharge chute. Let the auger and fan clear of snow before changing the working height of the snow blower.
- Operating at too deep of a cut allows snow to pass over the top of the snow blower housing. This snow will accumulate on the snow blower housing and can cause damage to hydraulic and electrical components.
- To stop blowing snow, stop forward travel and reverse direction for a short distance while leaving the snow blower at full speed and the same working height. Lower the machine RPM and stop the snow blower only after the snow blower has cleared of snow.
- NEVER run objects other than snow and ice through the snow blower.
- Travel at a slow speed and watch for objects buried in the snow.
- Let the auger break ice and snow into smaller pieces. Too large a piece of ice or snow will plug the auger, fan, and discharge chute.

NOTE: Large objects that are run through the snow blower will damage the auger, fan, and discharge chute.

Unplug the Snow Blower



WARNING



AVOID SERIOUS INJURY OR DEATH

Before operating or servicing system: read and understand the machine's owners manual. Follow the warnings and instructions in the manual when making repairs, adjustments, or servicing. Check for correct function after adjustments, repairs, or service. Untrained operators and failure to follow instructions can cause injury or death.



WARNING



AVOID SERIOUS INJURY OR DEATH

When Clearing a Plugged Snow Blower

- Never unplug a snow blower with the machine engine running!
- Never reach into the snow blower with your hands or feet to try and clear material.
- Do not raise the snow blower off the ground or work under the snow blower.
- Do not bounce the machine lift arms or bang the snow blower against another object to try and dislodge material.
- Verify that all tools have been removed from the snow blower before starting the fan and auger.

If the snow blower fan or auger is jammed with a foreign object, the hydraulics may be ran in reverse for a short period to try and dislodge the foreign object.

In the event of a plugged snow blower or foreign object that will not release with reverse hydraulic flow, stop forward travel, slow engine RPM, disengage auxiliary hydraulics, and remove the machine and snow blower from the work area.

Lower snow blower to the ground, stop the engine, set the parking brake, and exit the machine.

Use a shovel, bar, or piece of wood to remove material from the auger, fan, fan housing, and/or discharge chute. Never use your hands or feet to try and clear material.

3. Operation

3.5 Operating the Attachment Cont'd

Clearing a Plugged Snow Blower Cont'd

Unplug the Snow Blower Cont'd

Once the lodged material has been cleared, inspect the snow blower for damage to the auger, fan, fan housing, and/or discharge chute components. Replace any maintenance access panels removed to unplug and inspect the snow blower.

Repair or replace any damaged components before operating.

Enter the machine (see "Entering the Operator's Position" on page 11).

Start the machine and engage the machine auxiliary hydraulics at low engine RPM.

Check all snow blower functions for proper operation prior to returning to the work area.

Stopping the Snow Blower



CAUTION



TO STOP BLOWING SNOW

- Stop forward travel and reverse direction for a short distance while leaving the snow blower at full speed and at the same working height.
- Never shut off the snow blower with the auger and fan full of snow.
- Always allow auger and fan to clear of snow before changing the working height of the snow blower or shutting down the machine.

When the work area has been cleared, stop forward travel and reverse direction for a short distance while leaving the snow blower at full speed and at the same working height. Allow the snow blower auger and fan to completely clear of snow.

Rotate the chute to a center position and lower the deflector to the lowest position.

Move the engine speed control to low rpm and disengage the machine's auxiliary hydraulics. (See machine's operation manual for correct procedure).

Move the machine and snow blower from the work area. Park the machine and snow blower in a heated area if the snow blower will not be used again in the near future. Lower the machine lift arms and put the snow blower on the ground, tipped slightly forward to allow snow melt to drain from the auger, fan and fan housing.

Stop the engine, set the parking brake and exit the machine. (See "Leaving The Operator's Position" on page 11.)

Clear the snow blower of accumulated snow to limit snow melt and possible freezing of snow blower auger, fan, fan housing and other components.

3. Operation

3.5 Operating the Attachment Cont'd

Snow Blower Removal

NOTE: Rear skid pads must be fully retracted before removing the snow blower from the machine.

Before removing the snow blower from the machine, fully retract all rear skid pads.

NOTE: Put the snow blower on planks or blocks before removing the snow blower from the machine to prevent the snow blower from settling or sinking in soft / wet ground.

Lower the lift arms and put the snow blower flat on the ground.

Stop the engine and release auxiliary hydraulic pressure. (See machine's operations manual for correct operation.)

Exit the machine. (See "Leaving The Operator's Position" on page 11.)

Disconnect attachment hydraulic hoses from the machine.

Disengage locking pins / wedges. (See the machine's Operator's Manual for correct procedure.)

Disconnect the attachment control harness.

Enter the operator's position. (See "Entering The Operator's Position" on page 13.)

Slowly tilt the machine's mounting plate forward until the attachment mounting frame is free from the machine's mounting plate.

Drive the machine slowly backward, away from the attachment.



WARNING



AVOID SERIOUS INJURY OR DEATH

Before you exit the machine:

- Lower the lift arms, put the attachment flat on the ground.
- Stop the engine and engage the parking brake.
- Always keep your feet on the pedals or footrests and your hands on the controls.
- Move all controls until they are LOCKED or in the NEUTRAL position.

SEE THE MACHINE'S OPERATION MANUAL FOR MORE INFORMATION.

4. Maintenance

4.1 Service Schedule

Grease Points

! IMPORTANT !

Fluid such as hydraulic fluid, coolants, grease, etc. must be disposed of in an environmentally safe manner. Some regulations require that certain spills and leaks on the ground must be cleaned in a specific manner. See local, state and federal regulations for the correct disposal.

! WARNING !

AVOID SERIOUS INJURY OR DEATH

Always turn off and lockout power before servicing the snow blower.

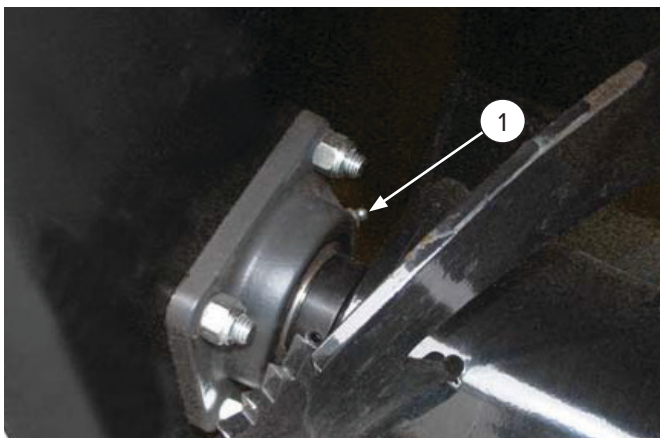

Figure 5

Grease the auger bearing (Item 1) [Figure 5] every 10 hours of operation.

Every 40 Hours:

- Check the chute rotate gear for correct alignment and wear or damage.
- Check the hydraulic hoses – routing and abrasion.
- Check the control harnesses – routing and abrasion.

! IMPORTANT !

Inspect all hydraulic hoses and wiring for wear and abrasion. Make sure hoses and wiring is secured and does not pinch or rub on sharp edges of the snow blower frame.

4.2 Cutting Edge Replacement

! WARNING !

AVOID SERIOUS INJURY OR DEATH

Wear safety glasses to prevent eye injury when any of the following conditions exist:

- When fluids are under pressure.
 - Flying debris or loose material is present.
 - Engine is running.
 - Tools are being used.
1. Park the machine on a level surface with the snow blower properly attached.
 2. Lower the snow blower's skid shoes onto two equal blocks approximately 2 to 3 inches in height and capable of sufficiently supporting the unit's weight.
 3. Engage the parking brake.
 4. Shut off the machine's engine, remove the starter key, wait for all moving parts to come to a stop, and relieve all pressure in the hydraulic lines.

4. Maintenance

4.2 Cutting Edge Replacement Cont'd

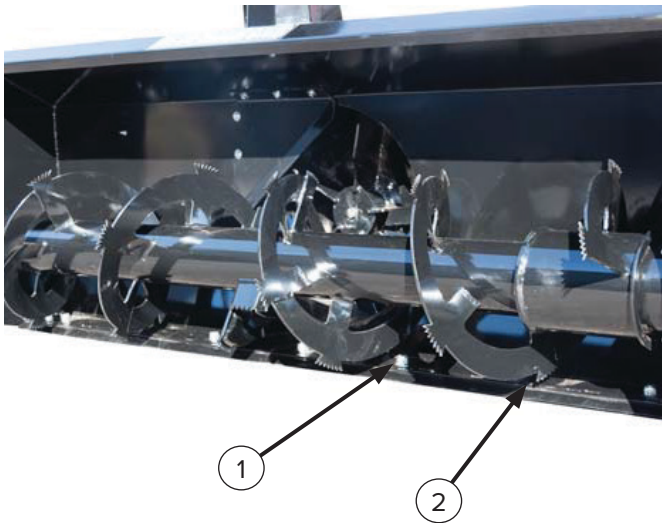



Figure 6

5. Remove all fasteners (Item 1) except the fasteners at each end of the cutting edge (Item 2) [Figure 6].
6. Remove one fastener at the end of the cutting edge and lower the cutting edge to the work surface. Then remove the remaining fastener.
7. Properly dispose of the old cutting edge and install a new cutting edge by reversing the steps listed here.

4.3 Rear Skid Pad Replacement

 **WARNING** 

AVOID SERIOUS INJURY OR DEATH
Securely block up the snow blower before working underneath.

1. Park the machine on a level surface with the snow blower properly attached.
2. Lower the snow blower's frame onto two equal blocks approximately 8" in height and capable of sufficiently supporting the unit's weight.
3. Engage the parking brake.

4. Shut off the machine's engine, remove the starter key, wait for all moving parts to come to a stop, and relieve all pressure in the hydraulic lines.

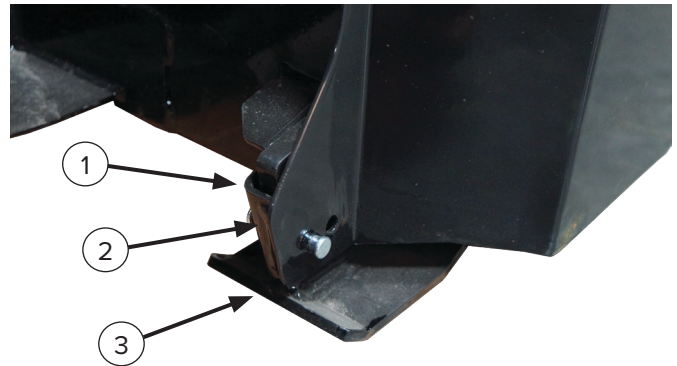

Figure 7

5. Remove the retaining pin (Item 1), pin (Item 2), and the skid pad (Item 3) [Figure 7].
6. Properly dispose of the old skid pad and install a new skid pad by reversing the steps listed here.

4.4 Rear Skid Pad Adjustment

Remove the retaining pin (Item 1) and pin (Item 2) then adjust the skid pad (Item 3) [Figure 7] to the desired height and install pin and retaining pin.

4. Maintenance

4.5 Chute Rotation Gear

Chute Rotation Gear

Check chute rotation and drive gears for proper alignment and that all hardware is secure.

NOTE: The chute rotation gears do not require any lubrication.

Check the gears for wear or damage. Repair or replace worn or damaged parts.

Chute Rotation Gear Adjustment

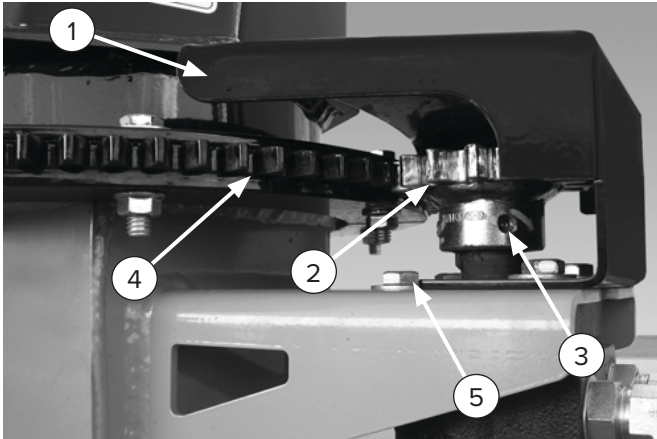

Figure 8

1. Remove chute rotate gear cover (Item 1) [Figure 8].
2. To adjust the drive gear (Item 2) alignment (height), loosen the drive gear set screws (Item 3), adjust height of drive gear, re-tighten set screws. Use loctite® on set screws. Drive gear (Item 2) should be centered on rotation gear (Item 4) [Figure 8].
3. To adjust the gear engagement (backlash), loosen motor mount bolts (Item 5) [Figure 8], adjust motor forward or backward to fully engage drive gear into rotation gears and tighten motor mount bolts (use loctite® on motor mount bolts).
4. Reinstall the chute rotate gear cover (Item 1) [Figure 8].

NOTE: Make certain chute rotate gear cover is replaced. Adjust cover so the rotation gear stop tab will not hit the cover.

Chute Rotation Gear Replacement

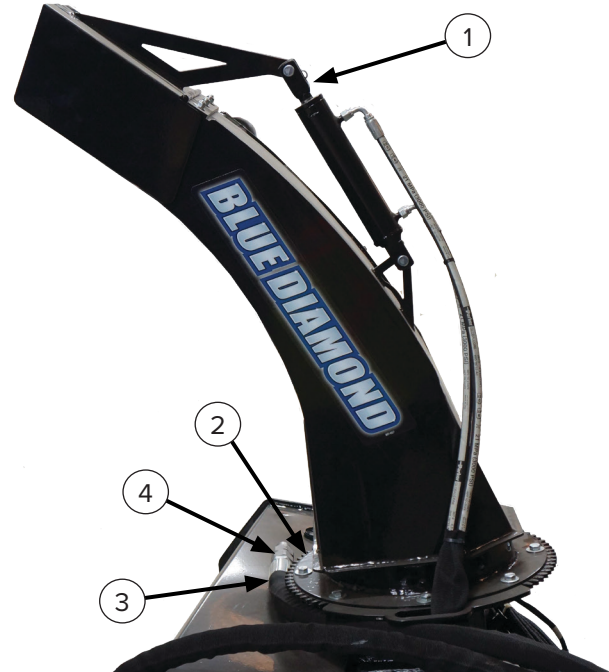

Figure 9

1. Remove the chute rotate gear cover (Item 1) [Figure 8].
2. Place a strap under the cylinder top clevis (Item 1) [Figure 9] and secure to a proper lifting device. Use lifting device and strap of adequate size (chute weight approx. 60 lbs).
3. Remove retainer hardware (Item 2) and retainer rings (Item 3) [Figure 9].
4. Loosen motor mount bolts (Item 5) [Figure 8] if needed to move drive gear.
5. Lift chute slightly and remove chute rotate gear (Item 4) [Figure 9] from top frame mount ring.
6. Replace the chute rotate gear around the top frame mount ring.
7. Set chute back down on top frame mount ring.
8. Reassemble hardware for chute rotate gear and retainer rings. Ensure that chute rotate gear is clocked so the stop tab (center) is 90° from the chute opening (opposite side of the chute rotate motor).

4. Maintenance

4.5 Chute Rotation Gear Cont'd

9. Remove hoist from discharge chute.
10. Install the chute rotate gear cover (Item 1) [Figure 8].

Check chute rotation gears for proper mesh and alignment. (See "Chute Rotate Gear Adjustment" on page 24).

Chute Drive Gear Replacement

1. To replace chute rotate drive gear (Item 2) [Figure 8], remove chute rotate gear cover (Item 1) [Figure 8].
2. Loosen drive gear set screws (Item 3) [Figure 8] and remove drive gear (Item 2) [Figure 8].
3. Replace drive gear at the desired height and backlash (see "Chute Rotation Gear Adjustment" on page 24) and tighten set screws. Use loctite® on set screws.
4. Install the chute rotate gear cover (Item 1) [Figure 8].

4.6 Cleaning the Attachment

Park the machine and attachment on a flat level surface. Lower the attachment flat on the ground.

Stop the engine.

Leave the operator's position. See "Leaving The Operator's Position" on page 13.

Disconnect attachment hydraulic hoses from the machine.

Enter the operator's position. See "Entering The Operator's Position" on page 13.

Slowly raise the machine's lift arms, while tilting the snow blower forward (down) until the front of the snow blower contacts the ground.

Stop the engine, engage parking brake and leave the operator's position. See "Leaving The Operator's Position" on page 13.

Use water or air pressure to clean debris from the snow blower.

Be careful when removing any obstructions that are wrapped around auger(s).

4. Maintenance

4.7 Troubleshooting

PROBLEM	CAUSE	SOLUTION
Snow blower does not operate	Skid steer main relief valve set too low.	Adjust main relief valve to correct setting.
	Skid steer fluid reservoir is too low.	Add hydraulic fluid to the fluid reservoir on the machine.
	Skid steer hydraulic pump faulty.	Check flow of hydraulic pump. Repair or replace as needed.
	Attachment control wire harness damaged or not connected properly to valve block.	Check connections, repair or replace wire harness.
	Damaged quick couplers.	Replace quick couplers.
	Auxiliary hydraulics not engaged.	Engage auxiliary hydraulics.
	Machine hydraulics engaged wrong direction.	Pressurize opposite line for correct blower rotation. Do Not reverse pressure couplers.
	Fan or auger has blockage or is frozen.	Remove debris from fan or auger. Thaw ice from fan and auger.
Chute does not rotate.	Faulty hydraulic motor or valve coil.	Repair or replace.
	Machine hydraulics not engaged.	Engage machine hydraulics.
	Machine control harness not connected or damaged wires.	Repair or replace.
Deflector does not adjust.	Faulty hydraulic motor or valve coil.	Repair or replace.
	Machine hydraulics not engaged.	Engage machine hydraulics.
	Machine control harness not connected or damaged wires.	Repair or replace.
Snow blower cuts too low.	Skid shoes out of adjustment.	Raise or lower skid shoes as needed.
	Snow blower tilted too low.	Adjust machines lift and tilt controls.
Snow blower leaving snow behind.	Cutting edge worn or damaged.	Replace the cutting edge.
	Snow blower tilted too far forward.	Adjust machines lift and tilt controls.
	Snow pads out of adjustment.	Raise or lower skid pads as needed.

4. Maintenance

4.7 Troubleshooting Cont'd

PROBLEM	CAUSE	SOLUTION
Snow Blower Poor Performance.	The hose from the pump to the motor is crimped or pinched.	Check for pinched areas and straighten the hose to allow fluid to flow freely.
	Solenoid valves may not be opening completely as a result from debris in the valve.	Remove the cartridge valves and soak in a petroleum based solvent to remove the build up. Clean cartridge valves with an air hose to finish removing any build up. See Figure 10 on page 28.
	The hydraulic fluid may be low.	Check the hydraulic oil level.
	Solenoid valves may not be operating with correct input voltage.	Check for 12V signal at valve coils.
	Engine RPM too slow.	Raise engine RPM.
	Machine's adjustable auxiliary flow rates are too low.	Adjust the machine's auxiliary flow rates to match snow blower rating. Adjust the machine to 3000 PSI (max) pressure. Enable machine high performance mode setting (engine speed max rpm).
	Excess return back pressure.	Service the machine return hydraulics system.
Snow blower is plugged.	Overloading snow blower.	Reduce travel speed. Reduce cut width.
	Stopping auger or fan.	Remove blower from snow before stopping auger and fan. Reverse direction without using lift arms to remove snow blower from snow.
	Using machine lift arms while running snow blower.	Reverse direction to remove snow blower from snow before adjusting blower working height.
Fan hits housing.	Fan is damaged.	Repair or replace fan paddles.
	Fan housing is damaged.	Repair or replace fan housing.
	Fan Motor mount bolts are loose.	Check fan motor mount bolts, tighten or replace as needed.

4. Maintenance

4.8 Hydraulic Manifold

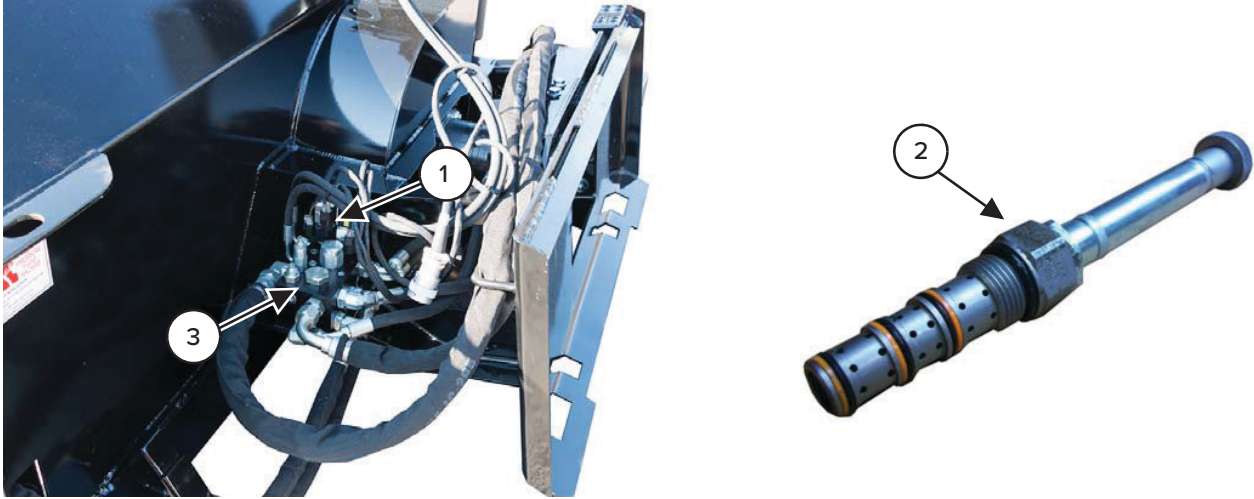

Figure 10

Remove solenoid valve(s) (Item 1) and the cartridge valve(s) (Item 2) from the hydraulic manifold (Item 3) [Figure 10]. Soak the cartridge valve(s) in a petroleum based solvent to remove the build up. Clean cartridge with an air hose to finish removing any build up.

NOTE: Place coils/valves in the correct position, as they are specific to each auxiliary function. Service only one coil/valve at a time to avoid incorrect installation.

! IMPORTANT !

DO NOT adjust hydraulic valves for flow or pressure. Field adjustment of hydraulic valves will damage hydraulic and mechanical components, voiding warranty.

Skid Steer Snow Blower Standard Operating Speeds and Pressures

	NO LOAD	STANDARD LOAD
Fan Speed (RPM)	550-850	500-800
Fan Pressure (PSI)	1200	2900-3000
Auger Speed (RPM)	132-216	125-200
Auger Pressure (PSI)	800	1100-1300

4. Maintenance

4.9 Hose Routing Table

Blower Hydraulic Plumbing

	219348 7-18 GPM VALVE	219366 19-25 GPM VALVE	
FUNCTION	END 1		END 2
Main Pressure	Valve P	Valve P	Male Coupler (loader arm female coupler)
Main Return	Valve T	Valve T	Female Coupler (loader arm female coupler)
Fan Pressure	Valve A	Valve M1A	Fan Motor A
Fan Return	Valve B	Valve M1B	Fan Motor B
Auger Pressure	Valve M1	Valve M2A	Auger Motor A
Auger Return	Valve M2	Valve M2B	Auger Motor B
Chute Rotate Left	Valve B1 (valve top port)	Valve A2 (valve top port)	Chute Rotate Motor A
Chute Rotate Right	Valve A1 (valve bottom port)	Valve B2 (valve bottom port)	Chute Rotate Motor B
Deflector Up	Valve A2 (valve bottom port)	Valve B1 (valve bottom port)	Deflector Cylinder Rod End
Deflector Down	Valve B2 (valve top port)	Valve A1 (valve top port)	Deflector Cylinder Base End
Fan Case Drain	(ref CD - not used)	DR	Fan Motor DR

4. Maintenance

4.10 Hydraulic Manifold Circuits & Connections

VALVE CIRCUIT	UPPER COIL CONNECTIONS	LOWER COIL CONNECTIONS	FUNCTION
1	C24 / Blue	C23 / Green	Chute Rotate Right / Left
2	C25 / Brown	C26 / Yellow	Deflector Up / Down

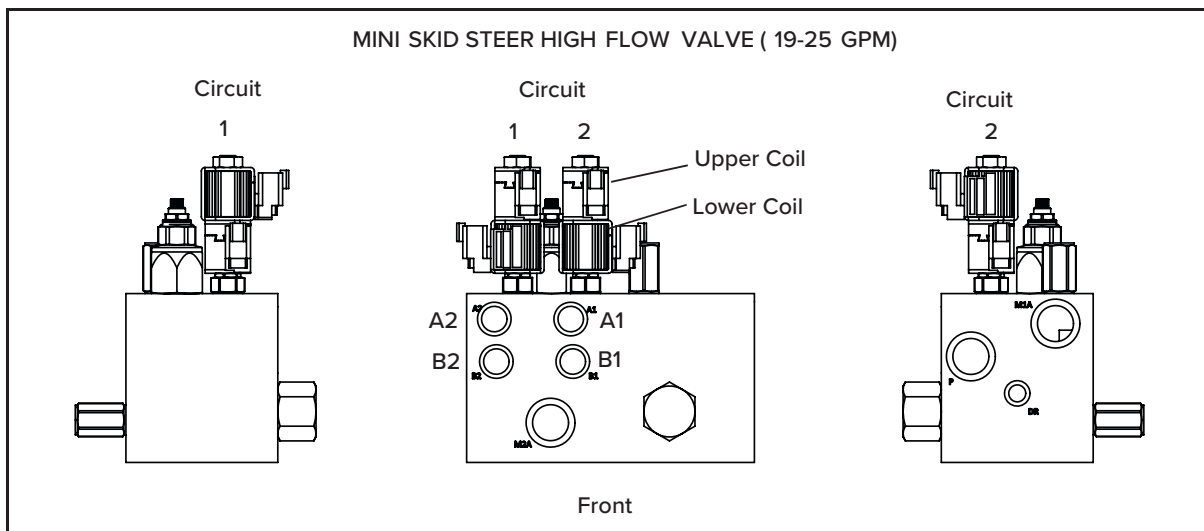
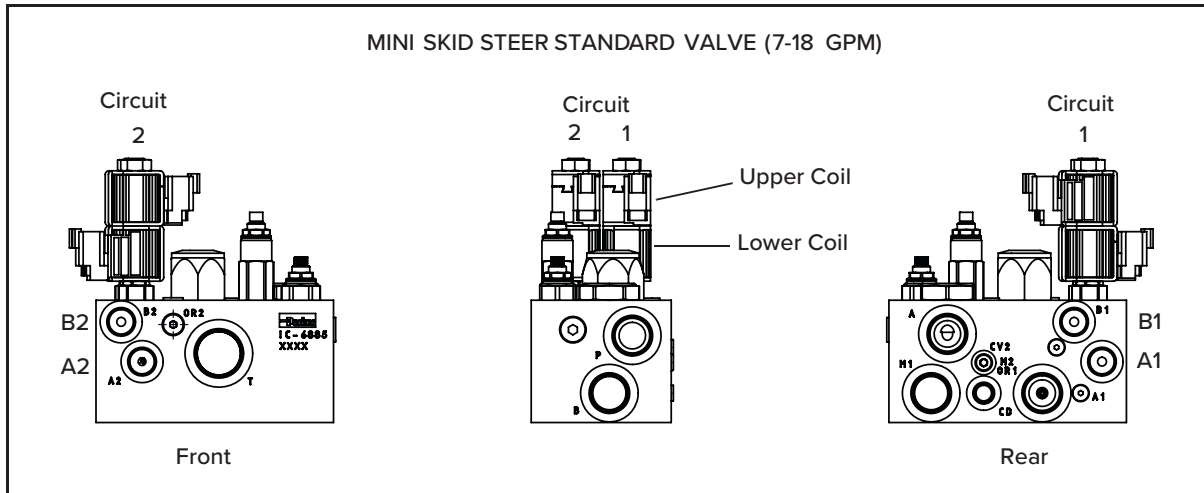

NOTE: Manifold Circuit Coil Terminations: Upper coil energizes bottom port
Lower coil energizes top port

Wiring Connector Tables

STANDARD BLOWER HARNESS		
CONNECTOR	CONNECT TO	FUNCTION
C18	Machine Bulkhead	—
C23 (Green)	#1 Lower Coil	Chute Left
C24 (Blue)	#1 Upper Coil	Chute Right
C25 (Brown)	#2 Upper Coil	Deflector Up
C26 (Yellow)	#2 Lower Coil	Deflector Down

5. Parts

5.1 Hydraulic Motor Selection (48", 54", 60", & 63")

SKID LOADER FLOW RATE	FAN MOTOR	AUGER MOTOR
7 — 9	219022	219019
10 — 13	219023	219019
14 — 18	219024	219020
19 — 25	219025	219021

Standard Flow Hydraulics

Snow blowers equipped with a motor package for 7 — 18 GPM will have a standard flow valve with fan and auger motors to match flow rate, and 4-blade fan hub to match small frame fan motors. Standard valves are for use with 12V machines with maximum 3000 PSI operating pressure and maximum of 25 GPM flow.

High Flow Hydraulics

Snow blowers equipped with a motor package for 19 — 25 GPM will have a high flow valve, with fan and auger motors to match flow rate and 4-blade fan hub to match large frame fan motors.

5.2 Attachment Control Harness Options

PART NUMBER	DESCRIPTION
119205	Universal Control Pendant: Pulls power from the skid steer battery
119210	Harness, Deere E-Series: Fits John Deere E-Series. Must have 14-pin connector on skid steer. Uses skid steer controls.
119225	Harness, CAT D-Series: Fits CAT D-Series with 14-pin connector on skid steer. Uses skid steer controls.
119215	Harness, 14 Pin Generic: Fits most other makes/models newer than 1995. Must have 14-pin connector on skid steer. Uses skid steer controls.

5. Parts

5.3 Main Components (48", 54", 60", & 63")

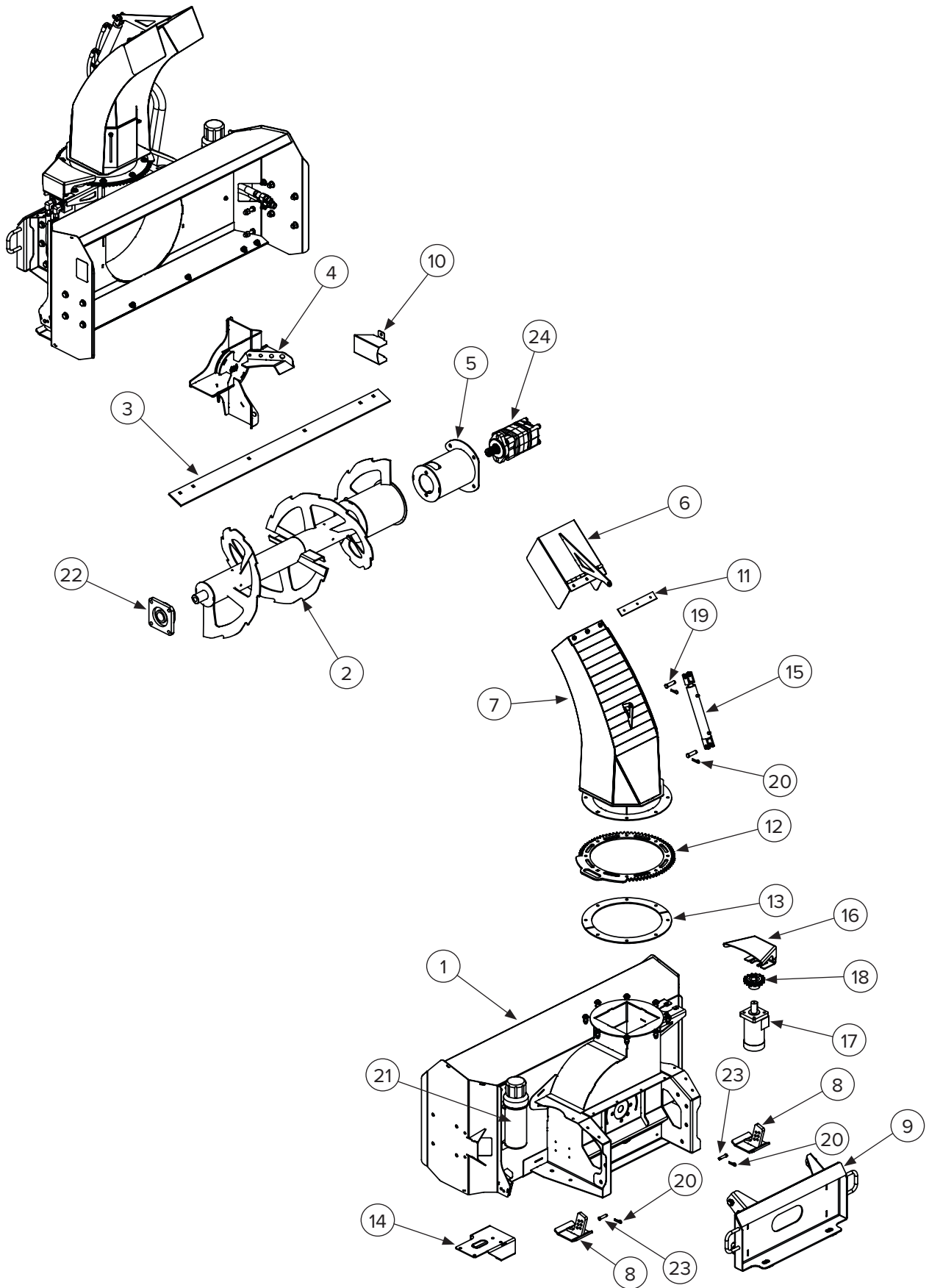

5. Parts

5.3 Main Components (48", 54", 60", & 63") Cont'd

ITEM	PART NUMBER	DESCRIPTION	QTY
1	—	Blower Shell Weldment	1
2	219026	48" Auger Weldment	1
	219028	54" Auger Weldment	
	219030	60" Auger Weldment	
	219032	63" Auger Weldment	
3	219027	48" Cutting Edge	1
	219029	54" Cutting Edge	
	219031	60" Cutting Edge	
	219033	63" Cutting Edge	
4	219000	Fan Weldment, 18"	1
5	219001	Housing Weldment, Auger Mount	1
6	219002	Deflector Weldment	1
7	219003	Spout Weldment, UTV Blower	1
8	219004	Skid Show Weldment	2
9	219015	Mini Universal Quick Attach Weldment	1
	219016	Skid Steer Quick Attach Weldment	
	219044	Bobcat MT Quick Attach Weldment	
10	219005	Auger Hose Cover, Inner	1
11	219006	Hinge Cover	1
12	219007	Rotation Gear, Small Spout	1
13	219008	Retainer Ring, Small Spout, LGTWT	1
14	219009	Valve Mount, Bolt On	1
15	219336	Hyd Cyl, 1.5" Bore X 5" ST	1
16	219337	Spout Gear Cover	1
17	219341	Hydraulic Motor, Spout	1
18	219342	Gear, 15T, 1" Bore	1
19	219344	Pin, Clevis 1/2" X 1-1/2 UI, Stl Zn	2
20	219345	Hairpin Cotter, 0.093 X 1-5/8, Zn	4
21	219346	Operator Manual Canister	1
22	219347	Bearing, 1-1/2", 4 Bolt, Cast	1
23	219013	Pin, Clevis 3/8 X 1-1/4 UI, Zinc	2
24	219019	Auger Hyd Motor 8 GPM / 12 GPM	1
	219020	Auger Hyd Motor 15 GPM / 20 GPM	

5. Parts

5.4 Hydraulic Components (7 – 18 GPM)

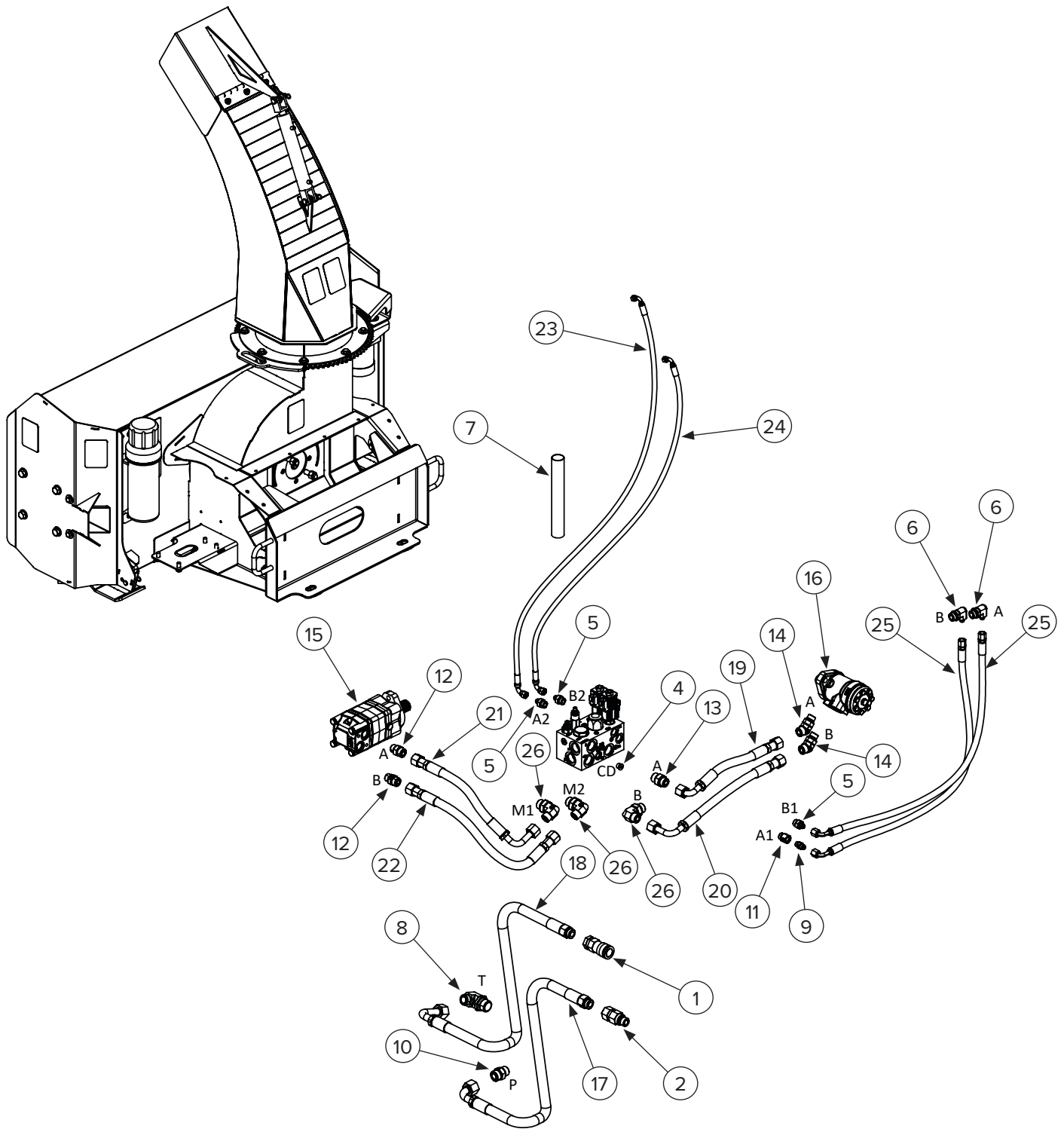

5. Parts

5.4 Hydraulic Components (7 – 18 GPM) Cont'd

ITEM	PART NUMBER	DESCRIPTION	QTY
1	—	Female HYD, Coupler, 1/2"	1
2	—	Male HYD, Coupler, 1/2"	1
3	219348	Manifold, Skid Steer	1
4	2196011	Counter Sunk Allen Plug	1
5	295010-M06JIC-M08ORB	HYD. Fitting, 6MJ-8MB STR	3
6	295030-M10ORB-M06JIC	HYD. Fitting, 6MJ-10MB90	2
7	219493	Hose Wrap Sleeve, 130 X 10.0	1
8	295030-M12FS-M16ORB	HYD Fitting, 12MFS-16MB90	1
9	298010-M06JIC-M06ORB	HYD Fitting, 6MJ-6MB. STR	1
10	295010-M12FS-M12ORB	HYD Fitting, 12MF-12MB, STR	1
11	295010-M08ORB-F06ORB	HYD Fitting, 8MB-6FOR, STR	1
12	295010-M10FS-M10ORB	HYD Fitting, 10MF-10MB, STR	2
13	295010-M10FS-M12ORB	HYD Fitting, 10MF-12MB, STR	1
14	295020-M10FS-M10ORB	HYD Fitting, 10MF-10MB, 45	2
15	219019	Auger Hyd Motor 8 GPM / 12 GPM	1
	219020	Auger Hyd Motor 15 GPM	
16	219022	Fan HYD Motor 8 GPM	1
	219023	Fan Hyd Motor 12 GPM	
	219024	Fan Hyd Motor 15 GPM	
17	In Hose Kit	Hose, Main Press, 12R12X63, 12MB-12FFX90	1
18	In Hose Kit	Hose, Main Ret, 12R12X68, 12MB-12FFX90L	1
19	In Hose Kit	Hose, Fan, 10R12 X 14, 10FFX-10FFX90S	
20	In Hose Kit	Hose, Fan Ret, 10R17 X 18,10FFX-10FFX90L	1
21	In Hose Kit	Auger Pressure Hose	1
22	In Hose Kit	Auger Return Hose	1
23	In Hose Kit	Hose, DEF-A, 4R17X69, 4FJX90S-6FJX90S	1
24	In Hose Kit	Hose, DEF-B, 4R17 X 62, 4FJX90S-6FJX90S	1
25	In Hose Kit	Hose, Rotate, 6R17 X 41, 6FJX-6FJX90S	2
26	295030-M10FS-M12ORB	HYD Fitting, 10MF-12MB, 90	3
NS	219014	Hose Kit for 48" & 54"	1
NS	219052	Hose Kit for 60" & 63"	1

5. Parts

5.5 Hydraulic Components (19 – 25 GPM)

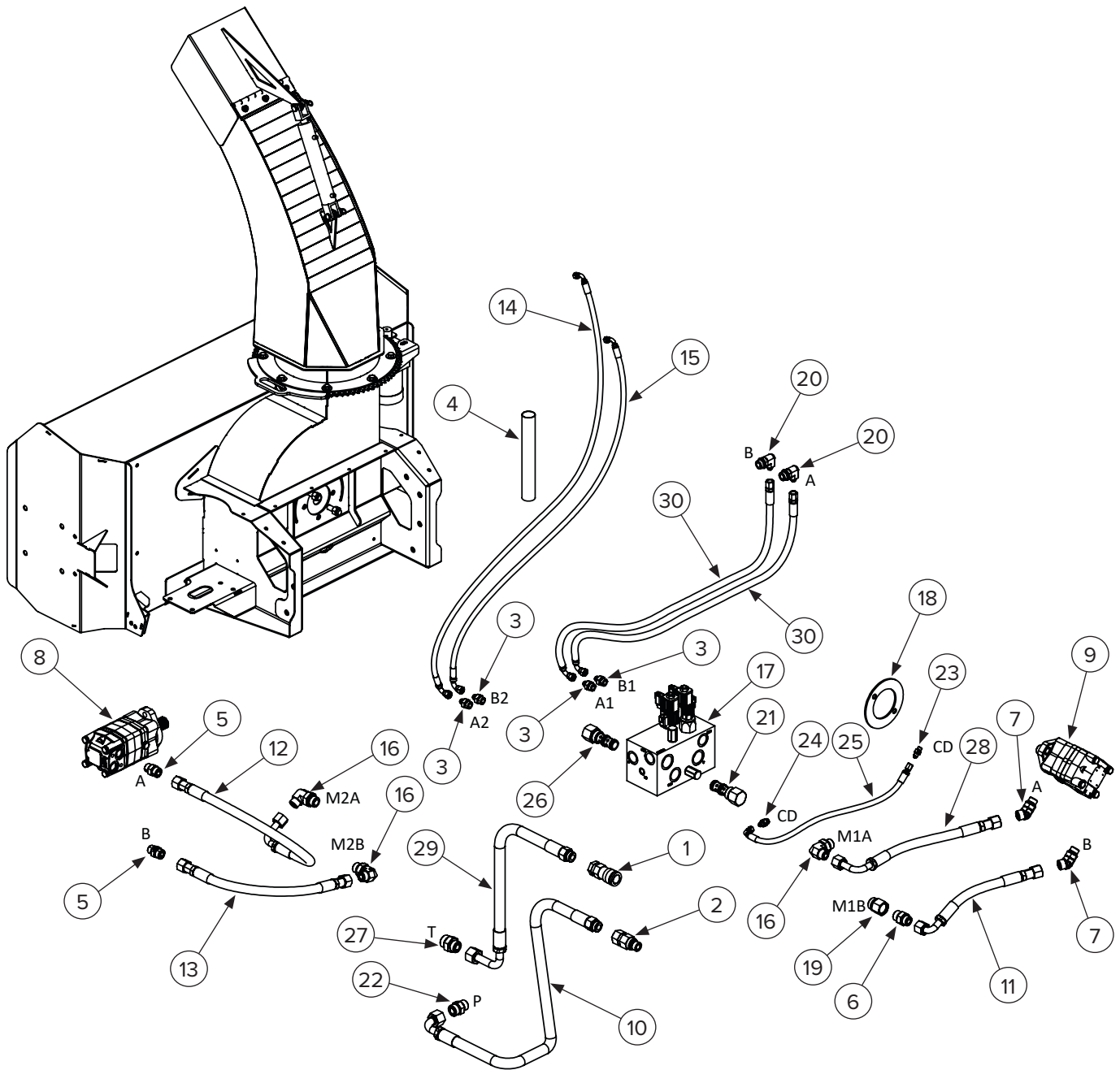

5. Parts

5.5 Hydraulic Components (19 – 25 GPM) Cont'd

ITEM	PART NUMBER	DESCRIPTION	QTY
1	—	Female HYD. Coupler, 1/2"	1
2	—	Male HYD. Coupler, 1/2"	1
3	295010-M06JIC-M08ORB	HYD. Fitting, 6MJ-8MB, STR	4
4	295010-M06JIC-M08ORB	Hose Wrap Sleeve, 130 X 10.0	1
5	295010-M10FS-M10ORB	HYD Fitting, 10MF-10MB, STR	2
6	295010-M10FS-M12ORB	HYD Fitting, 10MF-12MB, STR	1
7	295020-M10FS-M10ORB	HYD Fitting, 10MF-10MB, 45	2
8	219020	Auger HYD Motor, 20 GPM	1
9	219025	HYD Fan Motor, 20 GPM	1
10	In Hose Kit	Hose, Main Press, 12R12X63, 12MB-12FFX90	1
11	In Hose Kit	Hose, Fan, 10R12 X 14, 10FFX-10FFX90S	1
12	In Hose Kit	Auger Pressure Hose	1
	In Hose Kit		
13	In Hose Kit	Auger Return Hose	1
	In Hose Kit		
14	In Hose Kit	Hose, DEF-A, 4R17X69, 4FJX90S-6FJX90S	1
15	In Hose Kit	Hose, DEF-B, 4R17 X 62, 4FJX90S-6FJX90S	1
16	In Hose Kit	HYD Fitting, 10MF-12MB, 90	3
17	219366	Skid Steer High Flow Manifold	1
18	219047	Spacer, Fan Motor	1
19	295010-M14JIC-F12ORB	HYD Fitting, 14MB-12FOR STR	1
20	296030-M10ORB-M06JIC	HYD Fitting, 6MJ-10MB90	2
21	219380	Flow Regulator Cartridge, 25 GPM	1
22	295010-M12FS-M12ORB	HYD Fitting, 12MF-12MB, STR	1
23	295010-M04JIC-M04ORB	HYD Fitting, 4MJ-4MB STR	1
24	295010-M04JIC-M06ORB	HYD Fitting, 4MJ-6MB STR	1
25	219494	HYD Hose, 4R3 X 27, 4FJX-4FJX90S	1
26	219048	Flow Regulator Cartridge, 16 GPM	1
27	295010-M12FS-M16ORB	HYD Fitting, 12MF-16MB STR	1
28	219049	Hose, Fan, 10R12 X 19,10FFX-10FFX90L	1
29	219050	Hose, Main RET, 12R12X46, 12MB-12FFX90L	1
30	219051	Hose, Rotate, 6R17 X 45, 6FJX-6FJX90S	2
NS	219014	Hose Kit for 48" & 54"	1
NS	219052	Hose Kit for 60" & 63"	1

5. Parts

5.6 Decal Identification

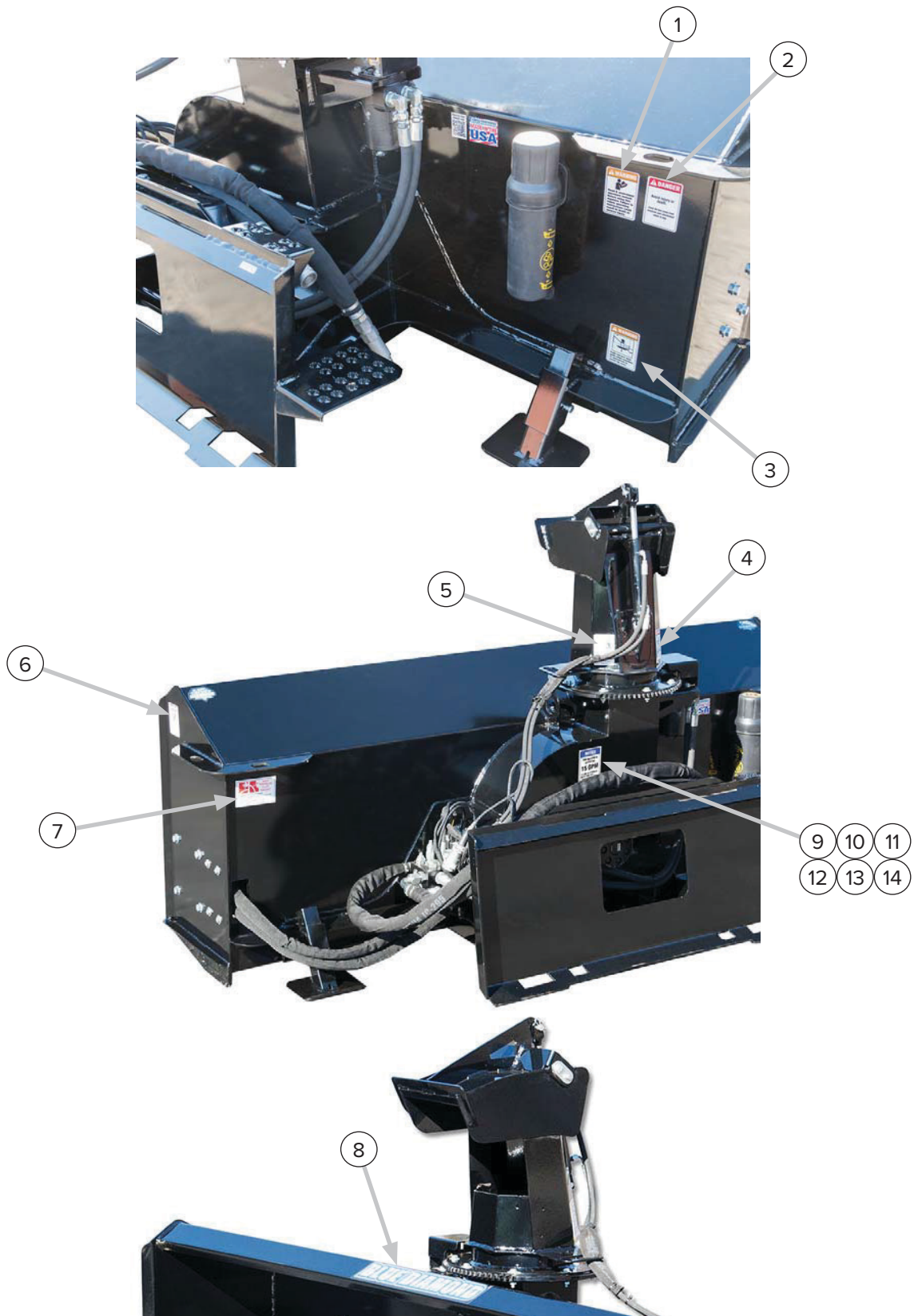

5. Parts

5.6 Decal Identification Cont'd

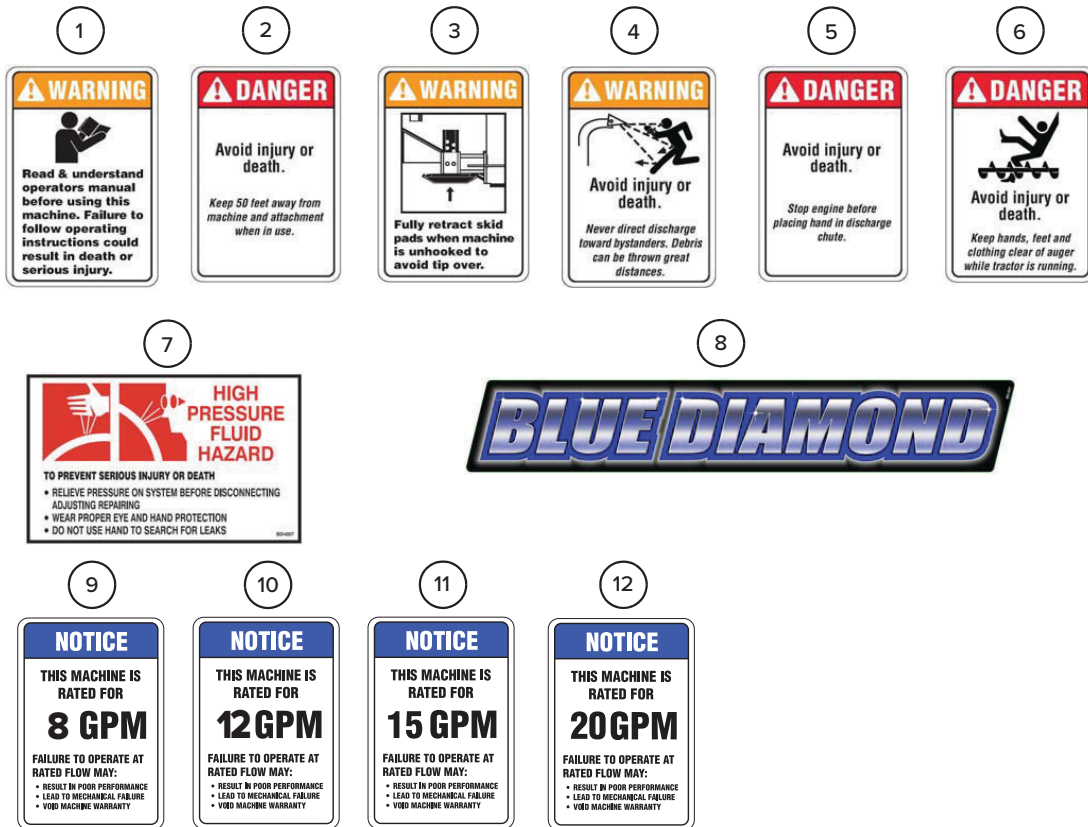

ITEM	PART NUMBER	DESCRIPTION	QTY
1	219395	Warning: Read Manual	1
2	219392	Danger: 50" Away	1
3	219394	Warning: Retract Skid Pads	2
4	219393	Warning: Direct Discharge Chute Away	1
5	219390	Danger: Hand in Discharge Chute	1
6	219391	Danger: Auger Running	1
7	219382	High Pressure Fluid Hazard	1
8	219383	Blue Diamond	1
9	219017	Decal, 8 GPM	1
10	219018	Decal, 12 GPM	1
11	219388	Decal, 15 GPM	1
12	219384	Decal, 20 GPM	1

5. Parts

5.7 Standard Blower Control Harness

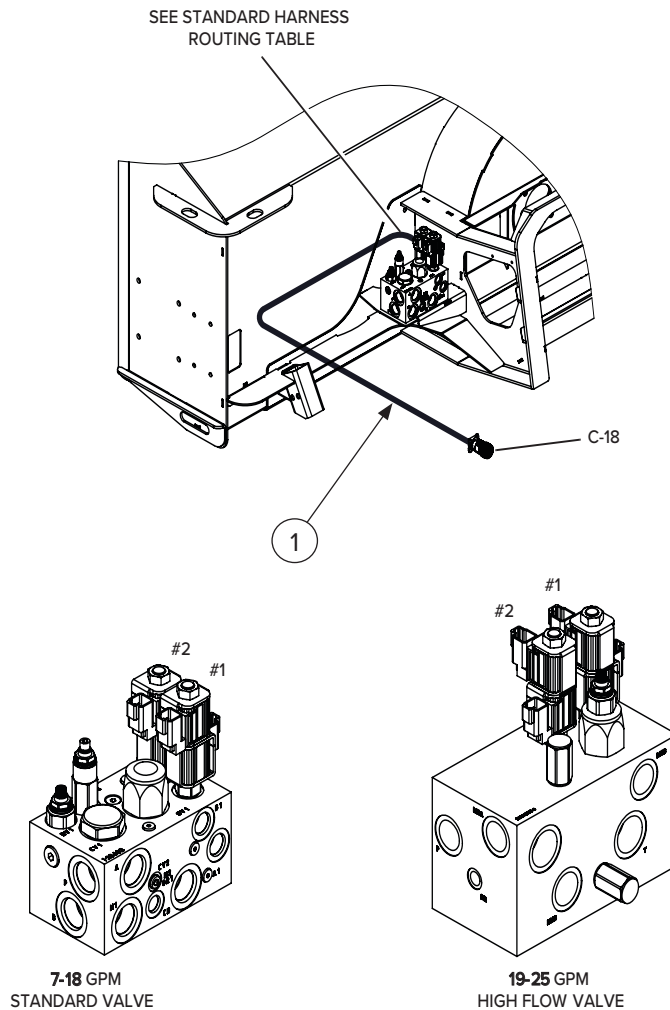

STANDARD BLOWER CONTROL HARNESS OPTION

ITEM	PART NUMBER	DESCRIPTION
1	119205	Universal Control Pendant: Pulls power from the skid steer battery
	119210	Harness, Deere E-Series: Fits John Deere E-Series. Must have 14-pin connector on skid steer. Uses skid steer controls.
	119225	Harness, CAT D-Series: Fits CAT D-Series with 14-pin connector on skid steer. Uses skid steer controls.
	119115	Harness, 14 Pin Generic: Fits most other makes/models newer than 1995. Must have 14-pin connector on skid steer. Uses skid steer controls.

STANDARD BLOWER CONTROL HARNESS ROUTING TABLE

CONNECTOR	CONNECT TO	FUNCTION
C18	Machine Bulkhead	—
C23 (Green)	#1 Lower Coil	Chute Left
C24 (Blue)	#1 Upper Coil	Chute Right
C25 (Brown)	#2 Upper Coil	Deflector Up
C26 (Yellow)	#2 Lower Coil	Deflector Down

6. Specifications

6.1 Attachment Specifications

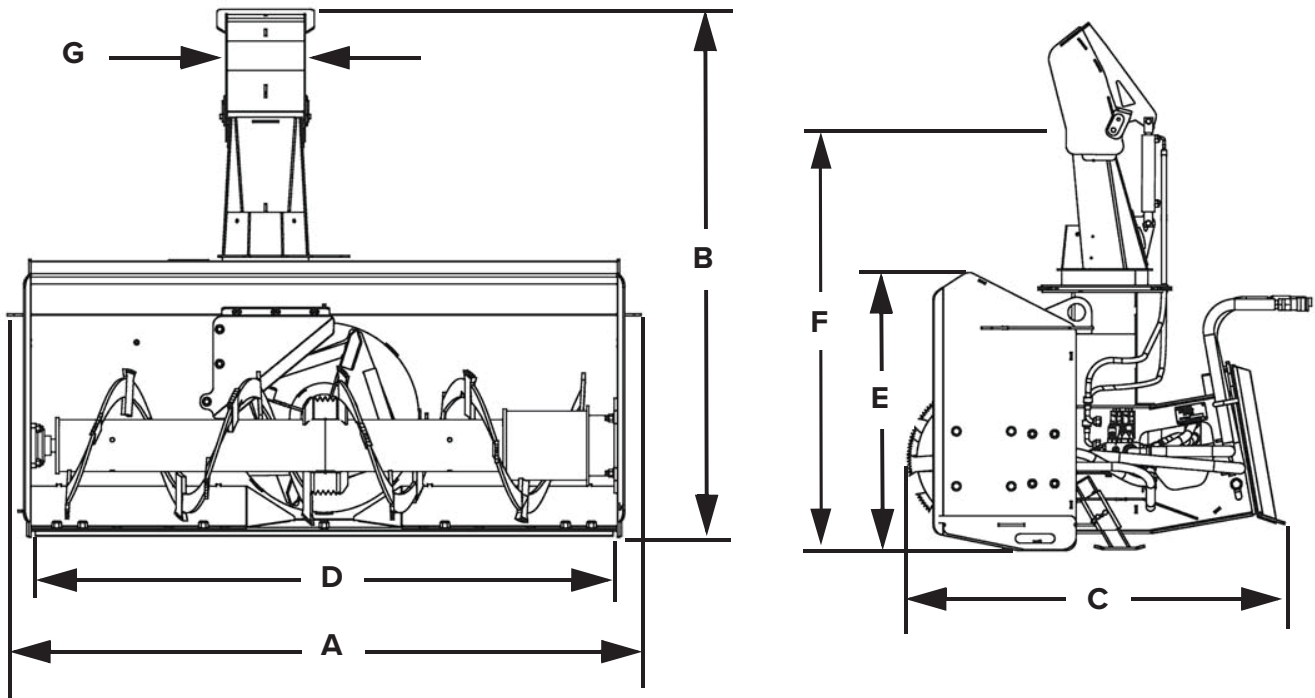

DESCRIPTION	48"	54"	60"	63"
Overall Width (A)	49.2"	55.2"	61.2"	64.2"
Overall Height (B)	58.3"			
Overall Depth (C)	35.3"			
Cutting Width (D)	48"	54"	60"	63"
Housing Height (E)	23.3"			
Discharge Height (F)	52.4"			
Chute Width (G)	8.13"			
Weight (approx.)	420 lb	430 lb	440 lb	450 lb
Fan	18"			
Fan Depth	6.75"			

6. Specifications

6.2 Torque Specifications

Standard Hardware and Lock Nuts

BOLT TYPE	SAE GRADE 5		SAE GRADE 8		LOCK NUTS			
	Nominal Size	Plated or Unplated Silver	Plated W/ ZnCr Gold	Plated or Unplated Silver	Plated W/ ZnCr Gold	Plated or Unplated Silver	Plated W/ ZnCr Gold	W/ Grade 5 Bolt
1/4	55 in / lb (6.2 N•m)	72 in / lb (8.1 N•m)	86 in / lb (9.7 N•m)	112 in / lb (12.6 N•m)	121 in / lb (13.6 N•m)	157 in / lb (17.7 N•m)	61 in / lb (6.9 N•m)	86 in / lb (9.8 N•m)
5/16	115 in / lb (13 N•m)	149 in / lb (17 N•m)	178 in / lb (20 N•m)	229 in / lb (26 N•m)	250 in / lb (28 N•m)	325 in / lb (37 N•m)	125 in / lb (14 N•m)	176 in / lb (20 N•m)
3/8	17 ft / lb (23 N•m)	22 ft / lb (30 N•m)	26 ft / lb (35 N•m)	34 ft / lb (46 N•m)	37 ft / lb (50 N•m)	48 ft / lb (65 N•m)	19 ft / lb (26 N•m)	26 ft / lb (35 N•m)
7/16	27 ft / lb (37 N•m)	35 ft / lb (47 N•m)	42 ft / lb (57 N•m)	54 ft / lb (73 N•m)	59 ft / lb (80 N•m)	77 ft / lb (104 N•m)	30 ft / lb (41 N•m)	42 ft / lb (57 N•m)
1/2	42 ft / lb (57 N•m)	54 ft / lb (73 N•m)	64 ft / lb (87 N•m)	83 ft / lb (113 N•m)	91 ft / lb (123 N•m)	117 ft / lb (159 N•m)	45 ft / lb (61 N•m)	64 ft / lb (88 N•m)
9/16	60 ft / lb (81 N•m)	77 ft / lb (104 N•m)	92 ft / lb (125 N•m)	120 ft / lb (163 N•m)	130 ft / lb (176 N•m)	169 ft / lb (229 N•m)	65 ft / lb (88 N•m)	92 ft / lb (125 N•m)
5/8	83 ft / lb (112 N•m)	107 ft / lb (145 N•m)	128 ft / lb (174 N•m)	165 ft / lb (224 N•m)	180 ft / lb (244 N•m)	233 ft / lb (316 N•m)	90 ft / lb (122 N•m)	127 ft / lb (172 N•m)
3/4	146 ft / lb (198 N•m)	189 ft / lb (256 N•m)	226 ft / lb (306 N•m)	293 ft / lb (397 N•m)	319 ft / lb (432 N•m)	413 ft / lb (560 N•m)	160 ft / lb (217 N•m)	226 ft / lb (306 N•m)
7/8	142 ft / lb (193 N•m)	183 ft / lb (248 N•m)	365 ft / lb (495 N•m)	473 ft / lb (641 N•m)	515 ft / lb (698 N•m)	667 ft / lb (904 N•m)	258 ft / lb (350 N•m)	364 ft / lb (494 N•m)
1	213 ft / lb (289 N•m)	275 ft / lb (373 N•m)	547 ft / lb (742 N•m)	708 ft / lb (960 N•m)	773 ft / lb (1048 N•m)	1000 ft / lb (1356 N•m)	386 ft / lb (523 N•m)	545 ft / lb (739 N•m)



Warranty

MANUFACTURER'S LIMITED WARRANTY

BLUE DIAMOND® ATTACHMENTS, a manufacturer of quality attachments, warrants new BLUE DIAMOND® ATTACHMENTS products and/or attachments at the time of delivery to the original purchaser, to be free from defects in material and workmanship when properly set up and operated in accordance with the recommendations set forth by BLUE DIAMOND® ATTACHMENTS, LLC.

BLUE DIAMOND® ATTACHMENTS liability for any defect with respect to accepted goods shall be limited to repairing the goods at a BLUE DIAMOND® ATTACHMENTS designated location or at an authorized dealer location, or replacing them, as BLUE DIAMOND® ATTACHMENTS shall elect. The above shall be in accordance with BLUE DIAMOND® ATTACHMENTS warranty adjustment policies. BLUE DIAMOND® ATTACHMENTS obligation shall terminate twelve (12) months for the Mini Snow Blower after the delivery of the goods to original purchaser.

This warranty shall not apply to any machine or attachment which shall have been repaired or altered outside the BLUE DIAMOND® ATTACHMENTS factory or authorized BLUE DIAMOND® ATTACHMENTS dealership or in any way so as in BLUE DIAMOND® ATTACHMENTS judgment, to affect its stability or reliability, nor which has been subject to misuse, negligence or accident beyond the company recommended machine rated capacity.

WARRANTY CLAIM

To submit a warranty claim, a claim must be filed with BLUE DIAMOND® ATTACHMENTS before work is performed. The BLUE DIAMOND® PRODUCT SUPPORT TEAM will advise repairs and applicable parts exchanges. Tampering with the failed part may void the warranty. This warranty does not include freight or delivery charges incurred when returning machinery for servicing. Dealer mileage, service calls, and pickup/delivery charges are the customers' responsibility.

EXCLUSIONS OF WARRANTY

Except as otherwise expressly stated herein, BLUE DIAMOND® ATTACHMENTS makes no representation or warranty of any kind, expressed or implied, AND MAKES NO WARRANTY OF MERCHANTABILITY IN RESPECT TO ITS MACHINERY AND/OR ATTACHMENTS ARE FIT FOR ANY PARTICULAR PURPOSE. BLUE DIAMOND® ATTACHMENTS shall not be liable for incidental or consequential damages for any breach or warranty, including but not limited to inconvenience, rental of replacement equipment, loss of profits or other commercial loss. Upon purchase, the buyer assumes all liability for all personal injury and property resulting from the handling, possession, or use of the goods by the buyer.

No agent, employee, or representative of BLUE DIAMOND® ATTACHMENTS has any authority to bind BLUE DIAMOND® ATTACHMENTS to any affirmation, representation, or warranty concerning its machinery and/or attachments except as specifically set forth herein.

This warranty policy supersedes any previous documents.

NOTE: Blue Diamond® Attachments is a trademark of BLUE DIAMOND® ATTACHMENTS



QUALITY | DEPENDABILITY | INTEGRITY

Blue Diamond® Attachments
4512 Anderson Road, Knoxville, TN 37918
888-376-7027