

Rototiller - Light Duty

Operation and Maintenance Manual

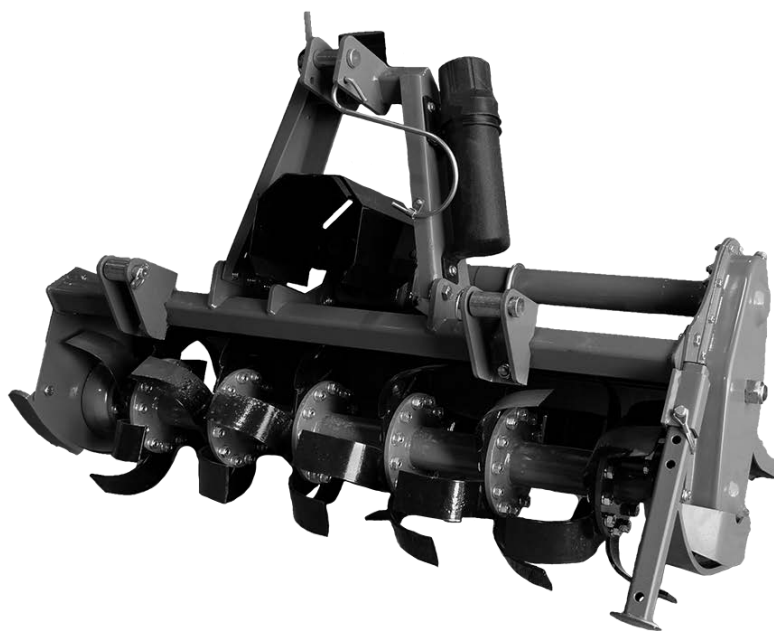

429010 - 4 ft Rototiller



*Register your
WARRANTY
within 30 days
of purchase*



888-376-7027 | BlueDiamondAttachments.com

Blue Diamond® Attachments



BD-092

Contents

- 1. ABOUT THIS MANUAL 1**
- 2. INTRODUCTION 1**
 - 2.1. TILLER IDENTIFICATION 1
 - 2.2. INTENDED USE 1
 - 2.3. MAIN PARTSDESCRIPTION 2
 - 2.4. TILLER SPECIFICATIONS 3
- 3. SAFETY 4**
 - 3.1. GENERAL SAFETY INSTRUCTION 4
 - 3.2. EQUIPMENT SAFETY INSTRUCTIONS 5
 - 3.3. OPERATING SAFETY INSTRUCTIONS 6
 - 3.4. TRANSPORTING SAFETY INSTRUCTIONS 7
 - 3.5. MAINTENANCE SAFETY INSTRUCTIONS 8
 - 3.6. STORAGE SAFETY INSTRUCTIONS 8
 - 3.7. SAFETY LABELS 9
- 4. SET UP 14**
 - 4.1. LOWER HITCHES POSITIONING 14
 - 4.2. CONNECTING TO THE TRACTOR 15
 - 4.3. DRIVELINE INSTALLATION 16
 - 4.4. TRACTOR-TILLER STABIUTY 17
- 5. OPERATING 18**
 - 5.1. START UP 18
 - 5.2. OPERATING INSTRUCTIONS 19
 - 5.3. ADJUSTMENTS 20
 - 5.4. STOPPING AND DISCONNECTION 22
 - 5.5. TRASPORTING 23
- 6. MAINTENANCE 24**
 - 6.1. BLADES REPLACEMENT 24
 - 6.2. GEARBOX LUBRICATION 25
 - 6.3. SIDE CASE LUBRICATION 26
 - 6.4. BEARING HOUSING LUBRICATION 27
 - 6.5. DRIVESHAFT MAINTENANCE 27
- 7. STORAGE 29**
- 8. SCRAPPING 29**
- 9. TROUBLESHOOTING 29**
- 10. TORQUE VALUES TABLE 31**
- 11. WARRANTY 32**
- 12. SPARE PARTS 32**
- 13. EC DECLARATION OF CONFORMITY (For CE Machines only) 32**

Owner Information

Thank you for your decision to purchase a Blue Diamond Rototiller. To ensure maximum performance of your equipment, it is mandatory that you thoroughly study the

Operator's Manual and follow the recommendations. Proper operation and maintenance are essential to maximize equipment life and prevent personal injury.

Operate and maintain this equipment in a safe manner and in accordance with all applicable local, state, and federal codes, regulations and /or laws. Follow all on-product labeling and instructions.

Make sure that all personnel have read this Operator's Manual and thoroughly understand safe and correct operating, installation and maintenance procedures.

Blue Diamond is continually working to improve its products. Blue Diamond reserves the right to make any improvements or changes as deemed practical and possible without incurring any responsibility or obligation to make any changes or additions to equipment sold previously.

Although great care has been taken to ensure the accuracy of this publication, Blue Diamond makes no warranty or guarantee of any kind, written or expressed, implied or otherwise with regard to the information contained within this manual. Blue Diamond assumes no responsibility for any errors that may appear in this manual and shall not be liable under any circumstances for incidental, consequential or punitive damages in connection with, or arising from the use of this manual.

Keep this manual available for frequent reference. All new operators or owners must review the manual before using the equipment and annually thereafter. Contact your Blue Diamond Attachments Dealer for assistance, information, or additional copies of the manual. Contact www.bluediamondattachments.com or call 888-376-7027 for a complete list of dealers in your area.

Serial Number Location

Please record attachment information in the space provided for future reference.

Model Number: _____

Serial Number: _____

Dealer Name: _____

Dealer Number: _____

Date of Purchase: _____

The serial number plate (is located on right side, just forward of the attachment mounting plate.

Always use your serial number when requesting information or when ordering parts.

NOTE: The directions left, right, front and rear, as mentioned throughout this manual, are as viewed from the operator's position.

1. ABOUT THIS MANUAL

The operator must read the manual for a correct understanding of the hazards that may present when operating the tiller, as well as for obtain optimum performance from the machine.

The manual is part of the machine, it must be kept in good condition and remain with the machine even in case of resale, until its demolition. In case of loss or damage, request a new copy to the Manufacturer or your Dealer.

The information, descriptions and illustrations in this manual describes the state of the product at the time of its publication, and may not reflect the product in the future.

The Manufacturer reserve the right to make design improvements or changes in specifications without incurring in any obligation to install them on units previously sold.

Text, illustrations and drawings of this manual cannot be disclosed or transmitted, in whole or in part, to third parties without the written permission of the Manufacturer. All rights are reserved.

2. INTRODUCTION

2.1. TILLER IDENTIFICATION

Each tiller has a plate for unique identification. Any request for assistance or information regarding the machine must be directed to the Manufacturer or Dealer always referring to the model and serial number as shown on the nameplate affixed to the machine:

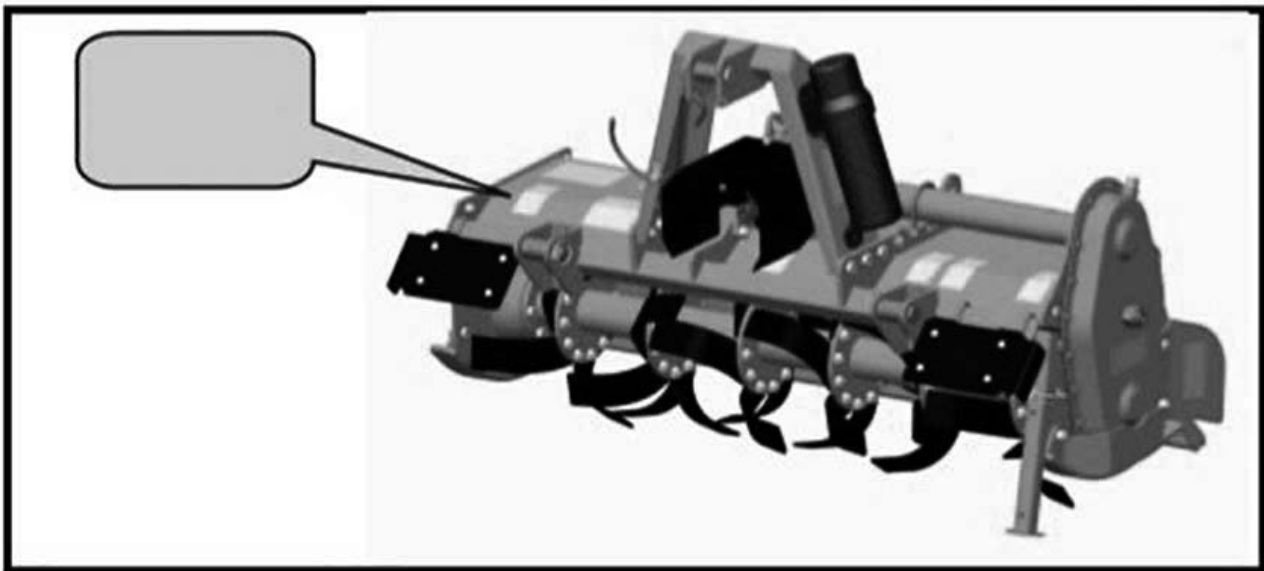

2.2. INTENDED USE

The U-series tillers are designed to be used uniquely for horticultural, agricultural, or commercial applications, to till soil for seedbed and planting preparation.

They are designed to be mounted on tractors equipped with hydraulic lift and universal three point hitch that can support the implement weight, and driven by the power of the tractor through the PTOdriveshaft.

The tractors used to operate the U-series tillers must have the following requirements:

Hitch Category: 3-point Cat. I standard, Compatible Quick Hitch I cat. ASAE
 PTO: 540 RPM, 6-spline, 1 3/8 Z6
 Horsepower: As per given in Technical Specification Sheet

⚠ DANGER

Any use of the machine other than the intended use is non-intended use, and is to be considered as unauthorized and dangerous. The manufacturer assumes no liability for damage resulting from non-intended use.

2.3 MAIN PARTSDESCRIPTION

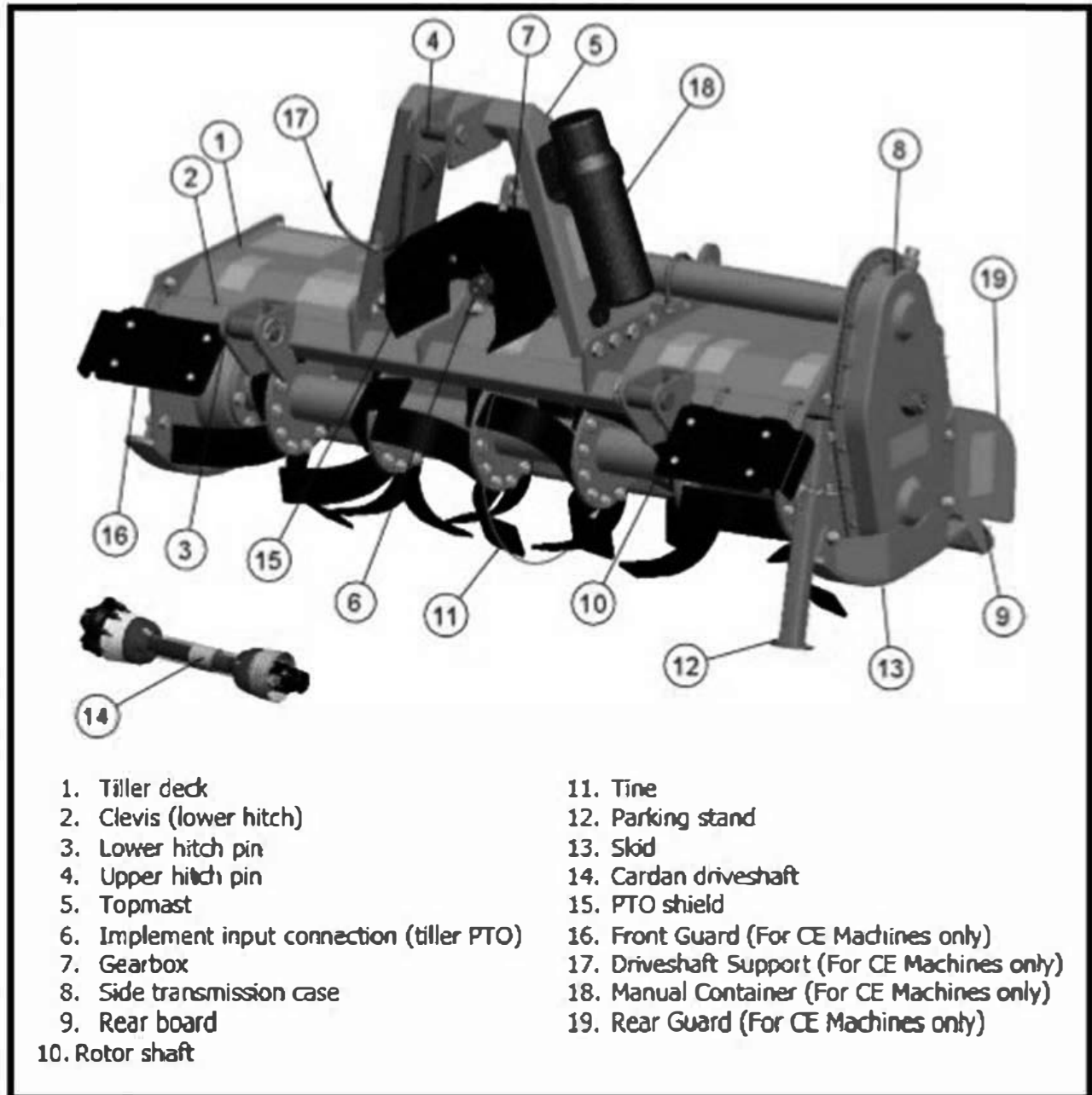

NOTE

Unless otherwise indicated, images shown in this manual refer to the tiller model wise.

2.4. TILLER SPECIFICATIONS

		TILLER MODEL		
				429010
Overall dimensions	mm			1340 x 805 x 600
Tilling width	in			48" 122
Recommended Tractor HP range	HP			20-35
3-point Hitch type	-			Cat. I, Compatible Quick Hitch I cat. ASAE
Frame off-set	in			4" or NIL*
Number of Flanges on Rotor	No.			6
Number of tines per Flange	No.			36
PTO Input speed	rpm			540
Rotor Shaft Speed	rpm @540			245
Standard Tine Construction	-			curved
Transmission type	-			gear
Max Working depth	cm			16
Rotor tube diameter	mm			70
Rotor Swing Diameter	mm			375
Driveline safety device				slip clutch
Weight (driveline excluded)	lbs			399
	Kg.			181

3. SAFETY

Proper use of equipment, a strict observance of the safety messages listed below and application of all reasonable practices to avoid any risks, prevents accidents or injury, allows the machine working better and longer, and minimize the failures. The manufacturer assumes no liability for any damage resulting from not applying the behavioral rules indicated into the manual.

3.1. GENERAL SAFETY INSTRUCTION

DANGER

The machine must be used only by authorized and well trained operators. The operator must have read and understood the instructions of this manual, it must make adequate preparation for the proper use of the machine and must hold a driving license. In case of doubt about the use of the machine and/or the interpretation of this manual, the operator must contact the Manufacturer or the Dealer.

WARNING

The manual must always remain with the machine. In case of loss or damage, request a new copy to the Manufacturer or your Dealer.

WARNING

Follow strictly the rules prescribed by the safety pictograms applied to the machine.

WARNING

Be sure that all safety pictograms are legible. If pictograms are worn, they must be replaced with others obtained from the Manufacturer, and placed in the position indicated by this manual.

DANGER

Before using the machine, make sure that all safety devices are installed and in good working conditions. In case of damages of shields, replace them immediately.

DANGER

Is absolutely forbidden to remove or alter safety devices.

DANGER

Before starting, and during operation of the tiller, make sure there are no people or animals in the operation area: the machine can project material from the back, with risks of serious injury or death.

DANGER

Pay maximum attention to avoid any accidental contact with rotating parts of the machine.

DANGER

During operation, adjustment, maintenance, repairing or transportation of the machine, the operator must always use appropriate Personal Protective Equipment (PPE).

DANGER

Do not operate the implement while wearing loose fitting clothing that can give rise to entanglement in parts of the machine.

 **DANGER**

Do not operate the implement when tired, not in good condition or under the influence of alcohol or drugs.

 **CAUTION**

If the use of the machine is required at night or in conditions of reduced visibility, use the lighting system of the tractor and possibly an auxiliary lighting system.

3.2. EQUIPMENT SAFETY INSTRUCTIONS

 **WARNING**

Use the tiller for its intended purpose only. Improper use can damage the tiller and cause serious injury to persons, animals, or death.

 **DANGER**

The machine should be used by a single operator driving the tractor.

 **WARNING**

Any unauthorized modification of the machine may cause problems in safety and relieves the Manufacturer from any liability for damages or injuries that may result to operators, third parties and objects.

 **WARNING**

Before using the machine, familiarize yourself with its controls and its working capacity.

 **WARNING**

Do not leave the tiller unattended with tractor engine running.

 **WARNING**

Do not operate tiller on too muddy, sandy or rocky soils.

 **WARNING**

Keep the machine clean from debris and foreign objects which may damage functioning or cause injury.

 **WARNING**

Do not use the machine if the category of the connecting pins of the tiller does not match that of the tractor hitch system.

 **WARNING**

Do not use the machine with missing bolts, screws, pins or safety pins.

 **WARNING**

Never use the machine to transport or lift people, animals or objects.

 **WARNING**

Make certain, by adding front ballast, that at least 20% of the total weight (tractor, implement and ballast) is on the front axle of the tractor, to ensure stability.

⚠ WARNING

Before engaging the tractor PTO, make sure the tractor PTO speed is set as required for the tiller (540 rpm). Do not over speed PTO or machine breakage may result.

⚠ DANGER

Do not operate the tiller if the driveshaft is damaged. The driveshaft could be subject to breakage during operation, causing serious injury or death. Remove the driveshaft and replace it with an undamaged.

3.3. OPERATING SAFETY INSTRUCTIONS

⚠ WARNING

Before using the machine, be sure to have cleared the operating area from obstacles (stones, branches, debris, etc...). Mark all the obstacles that cannot be eliminated (e.g. by means flags).

⚠ DANGER

Never engage the tractor PTO in the presence of people close to the driveshaft. The body, hair or clothing of a person can get caught in rotating parts, causing serious injury or death.

⚠ DANGER

Before engaging the PTO and during all operations, make sure that no person or animal is in immediate area of action of the machine. Never use the tiller if people are in his working area.

⚠ DANGER

It's absolutely forbidden to stand near the tiller with moving parts.

⚠ WARNING

The operator must operate tiller lifting/lowering only from the driving seat of the tractor. Do not perform lifting maneuvers on side or behind the tractor.

⚠ WARNING

Before making changes in direction, turns or going in reverse, slightly lift the tiller from the ground after disengaging the power take-off, to avoid damage to the machine.

⚠ DANGER

In presence of steep slopes (greater than 15 degrees) the tilling action may cause instability of the tractor, with risk of tipping and consequent serious injury or death hazard. Consult the manual for the tractor to determine the maximum slope that the tractor is able to deal with.

⚠ DANGER

Always disengage the PTO before raising the tiller, and never engage the PTO with the tiller in the raised position. The machine might throw objects at high speed, causing serious injury or death.

⚠ WARNING

Never leave the driver's seat when the tractor is turned on. Before leaving the tractor, lower the tiller to the ground, disengage the PTO, insert the parking brake, stop engine and remove the key from the control panel.

⚠ DANGER

The PTO shields of tractor and implement side, the driveshaft shielding and the driveshaft retaining chains must be properly installed and in good condition, to avoid risk of entanglement with serious injury or death.

⚠ DANGER

Before engaging the PTO of the tractor, always make sure that the drive shaft is mounted in the correct direction, and that its clamping elements are properly connected both to tractor side and to tiller side.

⚠ WARNING

Stop operating immediately if blades strike a foreign object. Repair all damage and make certain rotor and blades are in good condition before resuming operation.

⚠ WARNING

Always disengage the tractor PTO when the driveshaft exceed an angle of 10 degrees up or down while operating. An excessive angle with driveshaft rotating can break the driveshaft and cause flying projectiles.

⚠ CAUTION

Avoid clutch's overheating caused by too long or frequent slipping of the clutch, since it can damage the clutch components. Before checking slip clutch, make sure it has cooled. Clutch could be extremely hot and cause severe burn.

⚠ CAUTION

Prolonged use of the tiller can cause overheating of the gearbox. Do not touch the gearbox during use and immediately after, it could be extremely hot and cause severe burn.

⚠ WARNING

All adjustment operations on the tiller must be performed by qualified and trained operators, with the tractor engine off, the PTO disengaged, the tiller lowered to the ground or on security stands, the ignition key off and the parking brake set.

3.4. TRANSPORTING SAFETY INSTRUCTIONS

⚠ WARNING

Before transporting, determine the stopping characteristics of the tractor and implement.

⚠ WARNING

Transport only at speeds where you can maintain control of the equipment.

⚠ WARNING

When driving on roads, the implement must be in transport position adequately raised from the road surface, with tractor lifting hydraulics locked so that the tiller cannot be lowered accidentally.

⚠ DANGER

The implement may be wider than the tractor. Pay attention during transporting to persons, animals or obstacles exposed.

⚠ WARNING

When turning, use extreme care and reduce tractor speed.

⚠ WARNING

Do not operate the tractor with weak or faulty brakes or worn tires.

⚠ CAUTION

Always use tractor lighting system and auxiliary lighting system for an adequate warning to operators of other vehicles, especially when transporting at night or in conditions of reduced visibility.

⚠ DANGER

In case of tiller lifting, make sure that the lifting device chosen is suitable to perform the operation safely, and use only the lifting points prescribed on tiller.

3.5. MAINTENANCE SAFETY INSTRUCTIONS

⚠ WARNING

All maintenance and repairing operations must be performed by qualified and trained operators, with the tractor engine off, the PTO disengaged, the tiller lowered to the ground or on security stands, the ignition key off and the parking brake set.

⚠ WARNING

Perform repairs and replacements necessary to the machine using only original spare parts provided by the manufacturer or your dealer.

⚠ DANGER

Perform maintenance operations always using appropriate Personal Protective Equipment (protective eye glasses, hard hat, hearing protection, safety shoes, overall and work gloves, filter mask).

⚠ CAUTION

Before any maintenance operation, make sure that the parts which may become hot during use (friction clutch, gear box...) have cooled.

⚠ WARN4435G

Do not perform repairs that you do not know. Always follow the manual instructions and in case of doubt contact the Manufacturer or your dealer.

⚠ DANGER

Do not swallow fuels or lubricants. In case of accidental contact with eyes, rinse well with water and consult a doctor.

3.6. STORAGE SAFETY INSTRUCTIONS

⚠ WARNING

Never leave the tractor unattended with the tiller in lifted position. Accidental operation of lifting lever or a hydraulic failure may cause sudden drop of unit with injury or death by crushing.

⚠ DANGER

Following operation, or before unhooking the tiller, stop the tractor, set the brakes, disengage the PTO, lower the attached tiller to the ground, shut off the engine, remove the ignition key and wait for all moving parts to stop.

⚠ WARNING

Make sure all parked machines are on a hard, level surface and engage all safety devices.

⚠ CAUTION

Place support blocks under tiller as needed to prevent unit from tipping over onto a child and/or an adult. A tiller that tips over can result in injury or death.

⚠ CAUTION

Store the unit in an area away from human activity.

3.7. SAFETY LABELS

The safety labels applied on the machine give fundamental information for using the machine safely.





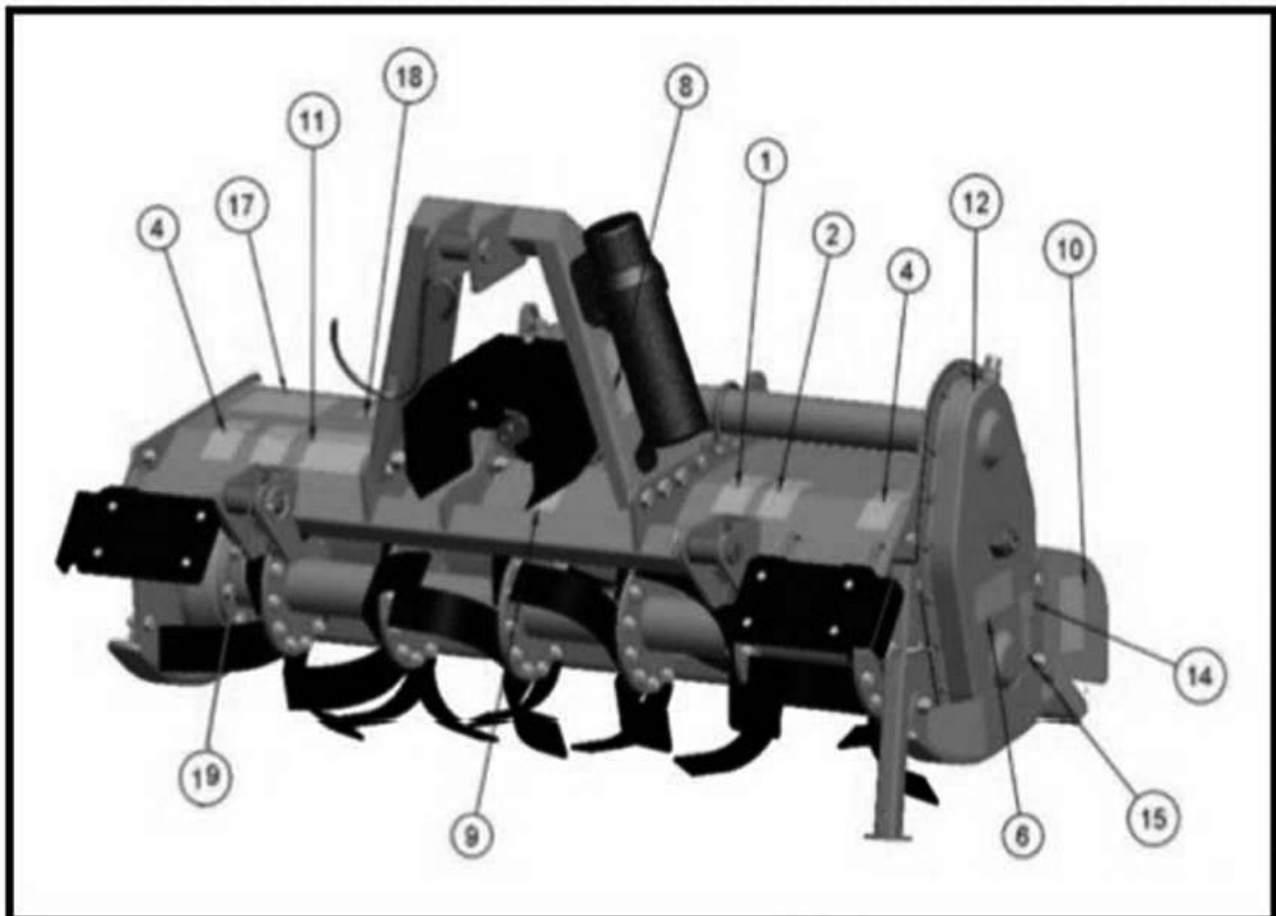

Make sure safety labels are in good conditions. If pictograms are worn, they must be replaced with others obtained from the manufacturer and placed in the position indicated by this manual.

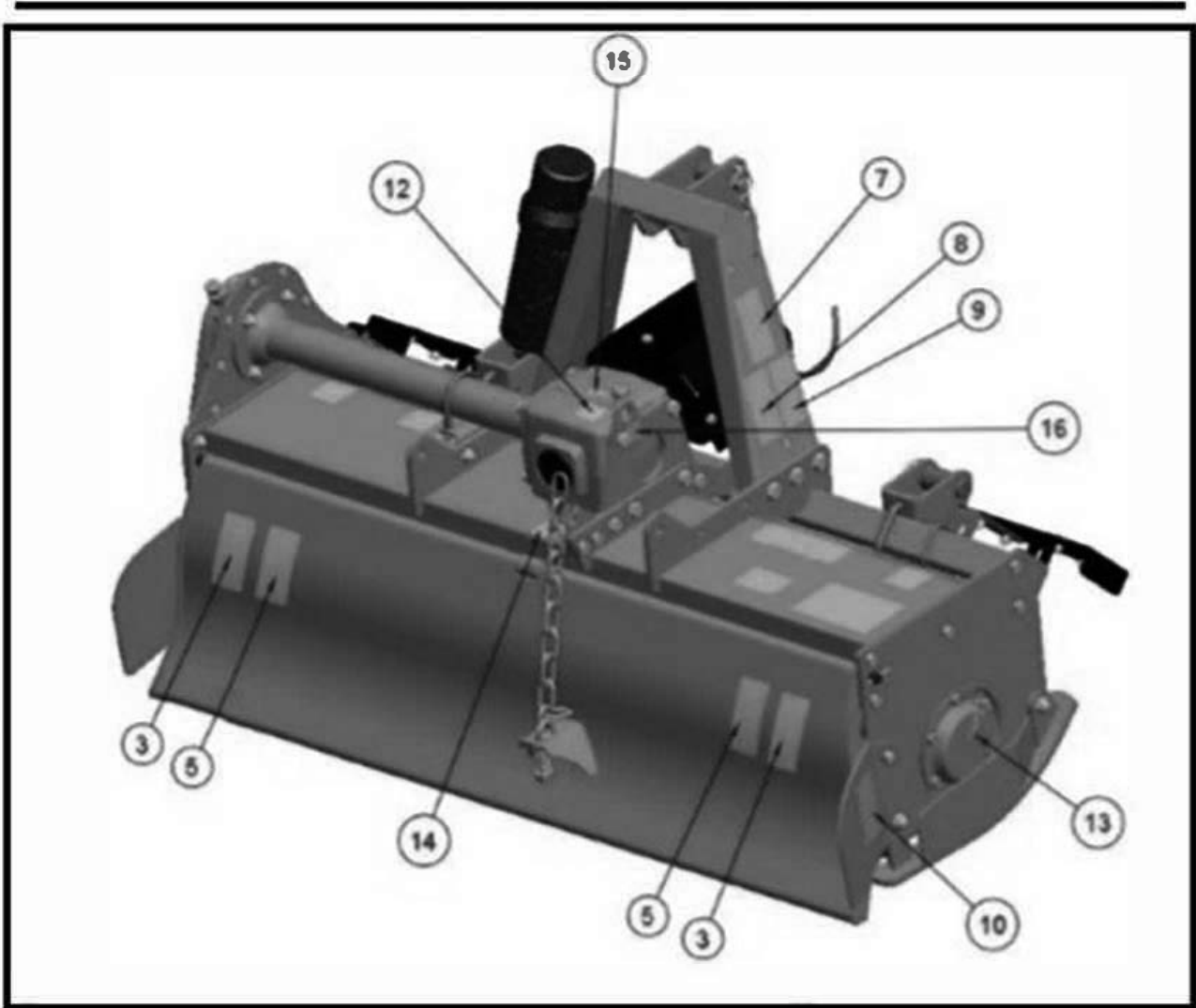





Make sure the safety labels are legible. If necessary, wipe them by a cloth, with soap and water.





Safety Labels position and description



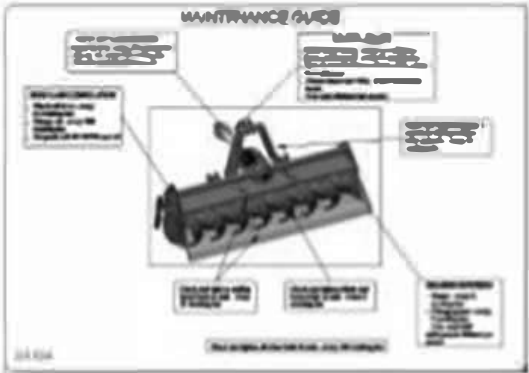

Sr. NO.	SPARE CODE	DESCRIPTION	DECAIS
1	D1090	WARNING: ALWAYS READ THE OPERATOR MANUAL	
2	D1038	MAINTENANCE: TURN OFF TRACTOR & REMOVE KEY	
3	D1095	THROWN OR FLYING OBJECTS HAZARD	
4	D1096	ROTATING KNIVES, LOWER LIMBS HAZARD	
5	D1078	HAND HAZARD	
6	D1079	ROTATING GEARS	

7	D1097	CRUSHING HAZARD BY LINK LIFTING	
8	D1098	IMPLEMENT INPUT DRIVELINE	
9	D1099	TRACTOR PTO RPM & ROTATION DIRECTION	
10	D1122	FINGERS/HANDS CRUSHING HAZARD	
11	D1082	SAFETY EQUIPMENT	
12	D1007	OIL FILLING PLUG – NEW	
13	D1008	GREASE – NEW	

14	D1009	OIL DRAIN PLUG	
15	D1006	MAINTAIN OIL LEVEL	
16	D1083	LIFTING HOOK JOINT	
17	D1104	MAINTENANCE GUIDE	
18	D1108	CE LOGO (For CE Machines only)	
19	D1092	DO NOT RIDE ON PLATFORM, KEEP DISTANCE	

4. SET UP

The tiller is delivered fully assembled and equipped with a driveshaft with torque limiter (clutch discs) and related operating manual.

When the machine is delivered, check that there is no damage to the tiller or driveshaft. In case of damage or missing parts immediately notify the manufacturer or your dealer.

4.1 LOWER HITCHES POSITIONING

The U-series tillers are designed to be mounted on tractors equipped with:

- 3-point Hitch Category I (ISO 730 standard);
- Quick Hitch Category I (ASABE Standard).

The position of the lower hitches must be adjusted accordingly.

If the tractor is equipped with a Quick Hitch Category I (ASABE Standard), verify that the lower devises show the pins oriented up (see figure), so that the distance between upper and the lower pins is 15" (381 mm), as required from the standard.

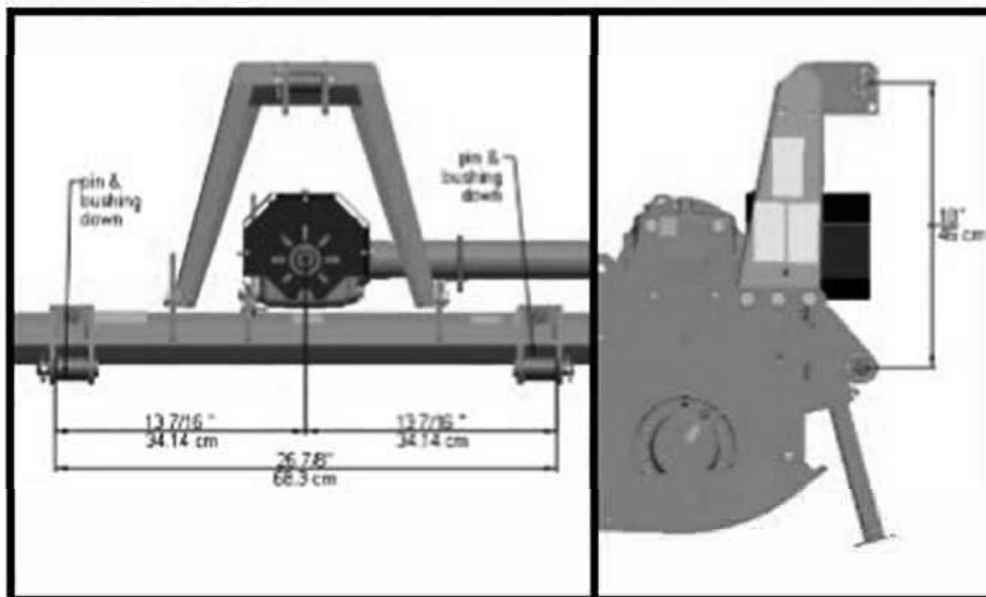

If this not occurs, proceed as follows for each of the two devises::

- remove the U-bolt and the devis from the square tube;
- invert the devis orientation and reposition it on the square tube at distance of 13 7/16" from the center of tiller PTO. At the end of the operation the lower devises should be positioned symmetrically respect to tiller PTO, at distance of 26 7/8" (683 mm);
- re-tighten the U-bolt, referring to the tightening table of this manual.

If the tractor is equipped with a 3-point Hitch Category I (ISO 730 standard), verify that the lower devises show the pins oriented down (opposite than figure above), so that the distance between upper and the lower pins is 18" (460 mm approx), as required from the standard.

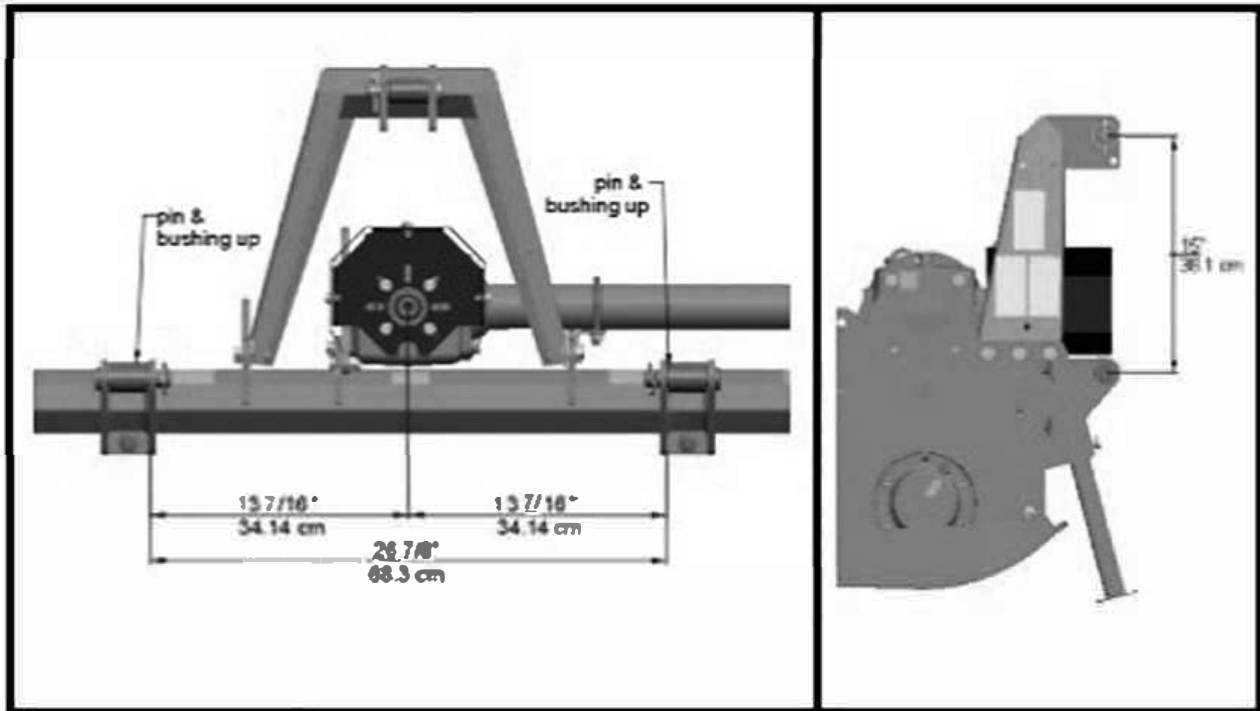

If this not occurs, proceed as follows for each of the two devises:

- remove the U-bolt and the devis from the square tube;
- invert the devis orientation and reposition it on the square tube at distance of 13 7/16" from the center of tiller PTO. At the end of the operation the lower clevises should be positioned symmetrically respect to tiller PTO, at distance of 26 7/8" (683 mm);
- re-tighten the U-bolt, referring to the tightening table of this manual;
- remove from upper and lower pins the bushings provided for coupling with Quick Hitch, through the extraction of elastic pins. Replace the elastic pins when finished. Store the bushings for possible future use.

4.2 CONNECTING TO THE TRACTOR

To connect the tiller to the tractor the operator must do the following:

- drive the tractor in reverse, up to align the rear lifting arms to lower hitches of the tiller in parking;
- set the tractor's parking brake, stop engine, remove the ignition key and get off the tractor;
- connect the lifting arms of the tractor to the lower hitches of the tiller, through the use of the pins and the relative safety split pins;
- raise the tiller until PTOs of tractor and machine are at the same height, then adjust the 3-point top link so that the front of the machine is leveled to the back (the axis of the tiller PTO must be parallel to the ground), in order to limit stress transmitted to the tiller through the cardan shaft;
- make sure that left side of the tiller is leveled with the right, by adjusting the tractor lifting arms, then lock the arms to prevent swinging that could compromise the stability of tractor and machine;

-
- finally adjust the parking stand, placing it at the highest point by means of the related elastic pin.

4.3 DRIVELINE INSTALLATION

Before installing the driveshaft, the operator must read the manuals of driveshaft and tractor, checking in particular that rpm and direction of rotation of the tractor PTO match those of the tiller.

If the direction of rotation of the PTO tractor does not match that of the tiller, contact the manufacturer or your dealer.

To connect the driveshaft to the tractor and implement, the operator must:

- park tractor and tiller on a flat surface, with parking brake set, engine off, and ignition key removed;
- check that safety devices of driveshaft, tiller and tractor are in good condition, otherwise provide for their replacement;
- remove the PTO shield of the tiller through the fixing screws;
- position the driveshaft with clutch turned towards the implement side;
- insert the clutch hub on the tiller PTO, then ensure its tightening onto shaft through its fastener;
- replace the PTO shield of the tiller through the fixing screws;
- insert the driveshaft yoke on the tractor PTO, then ensure its tightening onto shaft through its fastener;
- hook to the tractor and tiller the two retaining chains of the the driveline shielding, to prevent shielding rotation during functioning of the machine.

Driveline Length Check

Before operating the tiller, ensure that the size of driveshaft is adequate. The driveshaft supplied with the machine has a standard length, therefore it may need an adaptation of the length, depending of the tractor which the tiller is combined.

The length of the driveshaft must be such to:

- avoid bottom out of the transmission tubes, when the driveshaft is in compressed position (when tiller is raised up off the ground);
- Ensure an overlapping of the transmission tubes enough to transmit the torque required, when the driveshaft is in max extension (when tiller is in its lowest position in the ground).

When the driveshaft is at its minimum length (max compressed position), there must be at least a 2 cm of distance between the ends of each transmission tube and the yokes side.

When the driveshaft is at its maximum operational extension, there must be an overlap between the tubes profiles of 15 cm at least.

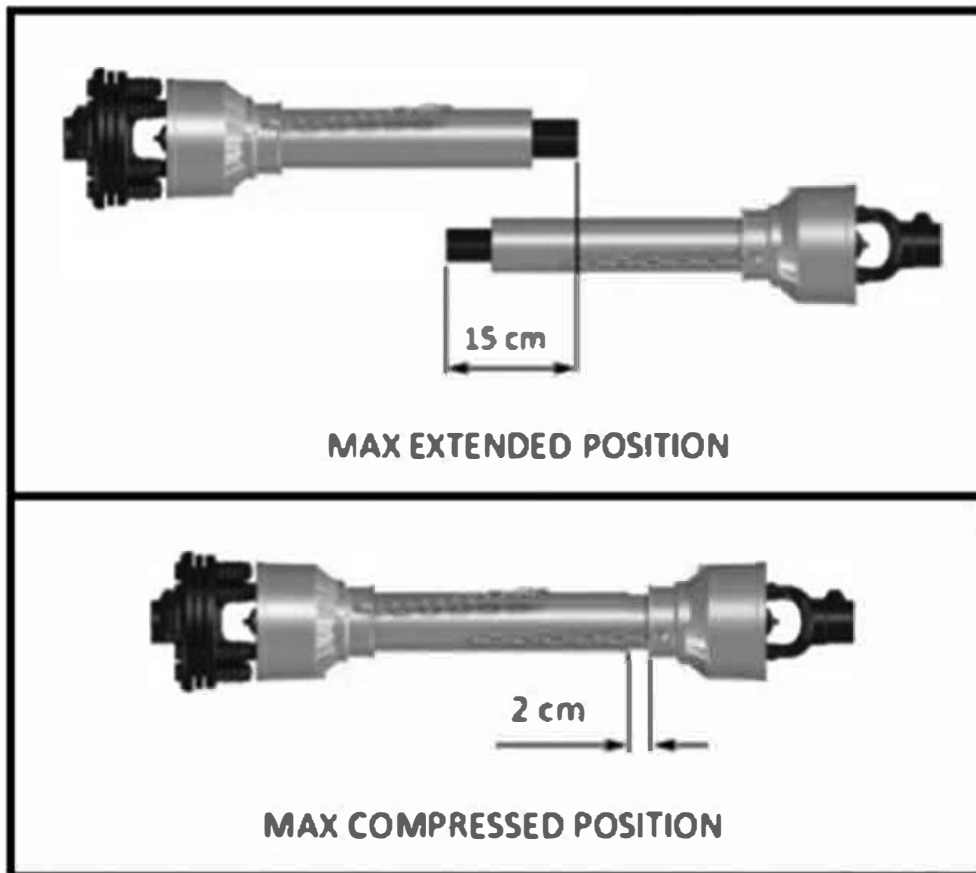

A driveshaft too long may cause structural damages to the tractor and machine. If the driveshaft is too long, it may be adapted by removing it and shortening the tubes according to the instructions provided by the manufacturer in its use and maintenance manual.

A driveshaft too short can cause disengage of the tubes during operation, with severe hazard for the operator and structural damage to the tractor and machine. If the driveshaft is too short, it must be replaced with a longer one. In this case contact the manufacturer or your dealer.

IMPORTANT

- before operating the tiller the first time, make sure that the driveshaft is lubricated in accordance with how indicated in the instruction booklet;
- before operating the tiller the first time, and after long periods of inactivity, make sure that the driveline clutch has run a short "run in" in accordance with what indicated in the instruction manual of the manufacturer, removing the possible oxidation of the components that may compromise the correct slipping during the usage (see also section "Maintenance");
- always engage the tractor PTO at low rpm to minimize the effect of the peak torque on the driveline and the machine.

4.4 TRACTOR-TILLER STABILITY

The weight of the machine modifies the stability of the system tractor-tiller, resulting in loss of steering control and braking.

The front axle of the tractor should always be loaded with at least 20% of the overall weight of the system tractor-tiller.



Check the lifting capacity and stability of the tractor and, if necessary, applying the front ballast. To determine the appropriate characteristics of the ballast, refer to the manual of the tractor.

5. OPERATING

Before operate the tiller, make sure you have read and understood the operating manuals of the tiller, tractor and PTO shaft, and followed what is described in the section "Set Up".

DANGER

During operation, adjustment, maintenance, repairing or transportation of the machine, the operator must always use appropriate Personal Protective Equipment (PPE).

Before starting work, ensure that all machine guards are in good conditions and fully functional.

During operation, the machine can throw material from the back: prevent people and animals to approach the operational area.

5.1 START UP

Before the start up and before each use, perform the following pre-operation inspections and service of the implement:

- check that the tiller has not damaged functional parts and has all mechanical parts in good condition. Repair and / or replace the damaged parts;
- check that the tiller has no missing parts (pins, safety pins, plugs oil ...). Restore the missing parts;
- check that all guards and safety devices have no damages and are properly positioned. Repair and / or replace the damaged shielding, restore the correct position;
- verify that the PTO driveshaft is properly installed (see section: Connection of the drive shaft);
- check that the driveshaft clutch is in good condition, and that its components are not subject to "sticking" (see section: Maintenance / Driveline);
- check the presence of lubricant in all greasing points of the tiller (driveshaft, supports...) (see sect. Maintenance / Driveline and Maintenance / Support rotor);
- check for oil leaks from the gearbox or the transmission side cover. Identify the reason of loss, then repair and / or replace the damaged components;
- check the correct oil level in the gearbox and in transmission side box (see section maintenance);
- check that blades are not excessively worn and the relating hardware is correctly tightened (see sect. Maintenance);
- check that all the tiller hardware is properly tightened. Refer to the tightening table in the manual for proper torque values;
- check that all safety decals are correctly positioned, in good condition and legible. Replace any damaged decals;
- check that there is no constraints that may prevent the movement of equipment. Remove any constraint.

Before the start up and before each use, make the following checks on the operating area identified for tillage:

- check that area is clear of foreign objects (rocks, branches or debris). Remove any obstacle and visibly highlight obstacles that cannot be eliminated (e.g. by means flags);
- make sure in the working area exposed there are no people or animals;
- make sure the soil to be worked is not too grassy, muddy, sandy or rocky.

WARNING

Before conducting the above inspections and service, make sure the tractor engine is off, all rotation parts are completely stopped and the tractor is in park with the parking brake engaged. Make sure the tiller is resting on the ground or securely blocked up and the tractor lifting hydraulics locked.

Once all the checks above have been done, start tractor and the tiller as follows:

- start the tractor and engage the tractor PTO at low rpm, making sure that the tiller is NOT in the raised position but close to the ground, then increase speed engine until to 540 rpm;
- lower the tiller on the ground and simultaneously start driving the tractor at low speed. Subsequently increase the ground speed depending on ground conditions;
- If the environmental temperature is very cold, it's recommended to wait a few minutes with the PTO of the tractor at low rate before lowering the tiller completely on the ground;
- drive for a while operating the tiller, then stop the tractor to check the quality of the work performed. If you need to get off the tractor, lift the tiller just out of the ground, reduce engine speed and disengage PTO, set the parking brake, stop engine and remove the ignition key;

If the working depth and/or soil texture are not as desired, correct them by adjusting the skids and/or the rear cover (see section Adjustments).

5.2 OPERATING INSTRUCTIONS

During operations:/ OPERATE ACCORDING TO FOLLOWING INTRUCTION

- always keep the tractor engine at rpm rate ensuring to the tiller the right power required for the use;
- always keep a tractor speed adequate to conditions of the soil to be worked (from 2 to 10 km / h approx.). Reduce speed in the case of hard or stony soils;
- choose a driving pattern that provides the maximum pass length and minimizes turning;
- when working in the hills, if you can do "climbing" in the sense of the slope, in any case do not work along the hillsides, making the steps from top to bottom to reduce the terrace. Where possible always try to «work up» the slope. If this is not possible avoid hoeing along the contours of the hill and hoe up and down the slope to avoid a terracing effect;
- always perform changes and reverse of direction with PTO disengaged and the tiller slightly lifted from the ground to avoid damage to the machine;
- periodically check for foreign objects wrapped around the rotor shaft and remove them, after disengaging PTO, turning off tractor engine, and removing ignition key;
- if the blades strike a foreign object, or in case of prolonged intervention of the clutch due to an object wedged into the rotor, stop operating immediately, idle the engine speed and disengage the PTO. Wait for stopping of all rotating parts, then raise the implement and proceed to removing the object, after stopped the tractor, set the parking brake, stopped engine and removed the ignition key. Repair any damages immediately, and make sure rotor and blades are in good condition before restarting operation;

- avoid friction clutch overheating caused by too long or too frequent slipping of the clutch, since this can damage the friction plates and clutch parts.

Typical problems that may occur operating the tiller are described into Troubleshooting section, together with their solutions.

5.3 ADJUSTMENTS

⚠ WARNING

All adjustment operations must be performed with the tractor engine off, the PTO disengaged, the tiller lowered to the ground or on security stands, the parking brake set and the ignition key off.

LOWER CLEAVISES ADJUSTMENT

It is possible to adjust the lower hitch position loosening the bolts 1 (see picture) and sliding the device 2. Tighten the bolts after making any adjustment required.

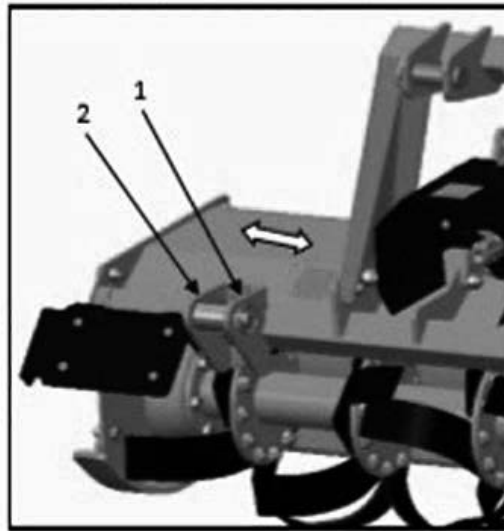

FRICITION CLUTCH ADJUSTMENT

The PTO driveshaft and friction clutch are designed to transmit adequate power to the tiller.

The clutch preserves the machine from overloads, through the slipping of friction discs, and limits the max torque transmissible to a calibrated value set at factory. It is recommended, therefore, to leave unchanged this value to avoid damages to the machine or to driveshaft.

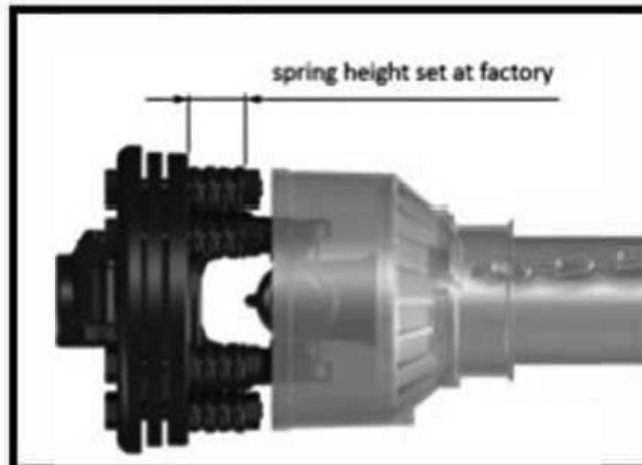

An adjustment can be done, however, when the clutch slipping is too frequent, which means that the calibration is too low.

In this case, the tightening of nuts over the compressed springs will give an increase in torque transmissible.

On the contrary, a loosening of the nuts over the springs will give a decrease in torque transmissible.

IMPORTANT

For details about clutch adjustment, refer to the user manual of the manufacturer of the driveshaft installed.

The manufacturer is not liable for damages resulting from a wrong modification of the clutch calibration.

NOTE

Excessive tightening of the springs can prevent the clutch from slipping and to protect the machine from overload.

Make sure that the height of all the compressed springs is equal to prevent clutch malfunctioning.

SKIDS ADJUSTMENT

The working depth of the tiller is determined by the position of the side skids: it may be increased by raising the skids, and decreased by lowered them. It's important that both skids are adjusted at the same height.

To adjust the working depth, perform the following steps:

- lift the machine, put it safely on security stands, then switch the tractor engine off, disengage PTO, set parking brake and off the ignition key;
- loosen the in the front of the skid (bolt 1 - see picture);
- unscrew and remove the bolt on the rear of the skid (bolt 2 - see picture);
- adjust the height of the skid through the holes, as desired;
- reinstall the bolt 2 (refer to the tightening table of this manual for proper torque values);
- tighten the bolt 1 (refer to the tightening table of this manual for proper torque value).

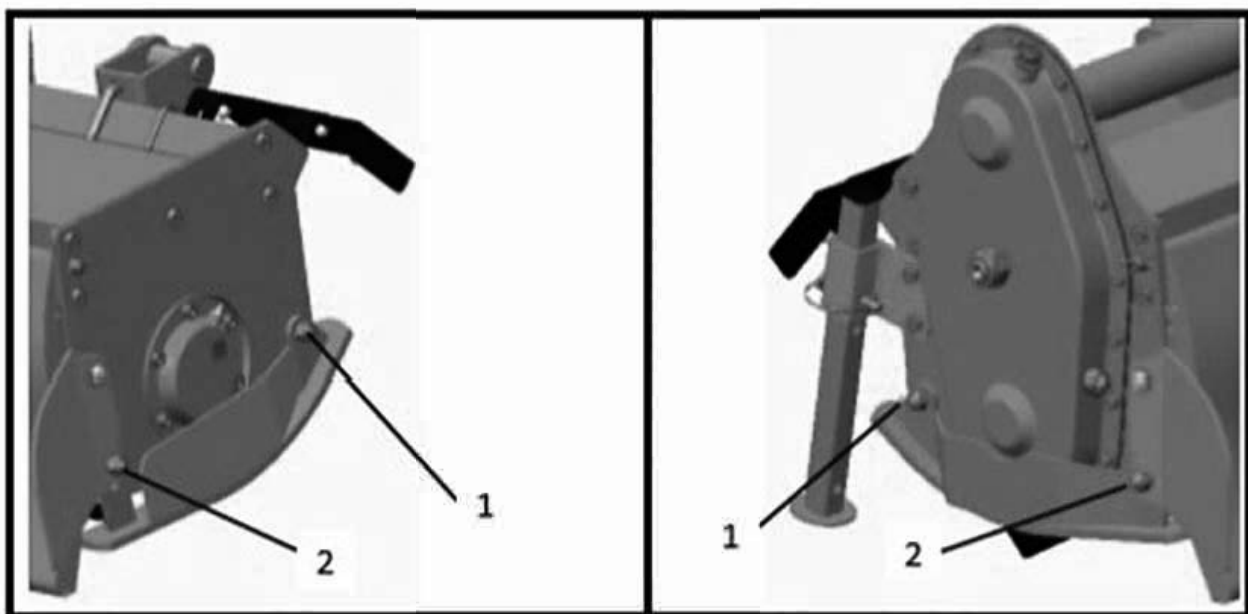

When finished, verify that both skids are at same level, and check if the front of the tiller is leveled to the back, when lowered to the ground. Adjust with the 3-point top link if necessary.

REAR BOARD ADJUSTMENT

The U-Series tillers are equipped with a rear board with chain.

The position of the rear board is adjustable by varying the number of chain links included between distance XY, which remain tensioned under the weight of the board (i.e. links between the rear board U-bolt 1 and the slot of the frame 2).

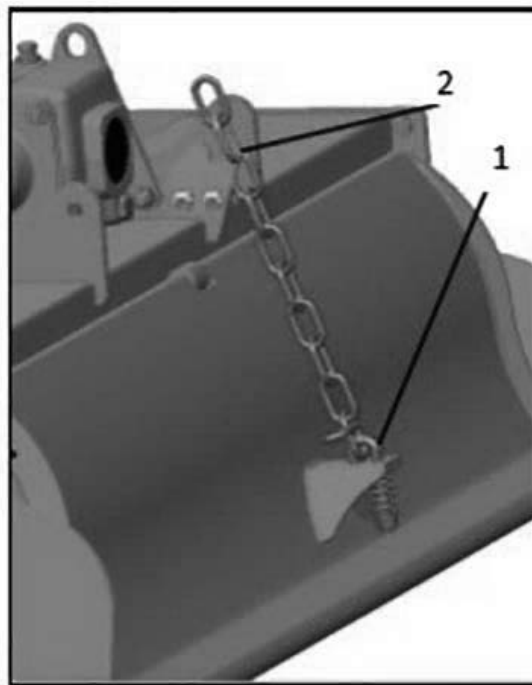

- to raise the rear board, reduce the number of chain links in tension. This operation, together with the increase of the tractor ground speed, allows to have a coarser soil texture;
- to lower the rear board, increase the number of chain links in tension. This operation, together with the reduction of the ground speed, allows to have a finer soil texture.

⚠ WARNING

To avoid the risk of crushing or cutting of fingers, raise or lower the rear board only from the lower edge, not from the sides.

5.4 STOPPING AND DISCONNECTION

To stop the tiller at the end of a working session:

- bring the tractor to a complete stop;
- place the transmission in park or neutral;
- reduce the engine speed, then disengage the PTO;
- wait for stopping of all rotating parts;
- lower the implement to the ground;

-
- set the parking brake;
 - shut down the engine and remove the key before exiting the tractor;
 - do the cleaning and maintenance required to make the machine ready for later use (see Section Maintenance).

 WARNING

Never leave the tractor unattended with the implement in the lifted position.

To disconnect the tiller from the tractor (e.g. to make a change of implement):

- adjust the skids to their lowest position (see Section Adjustments);
- adjust the parking stand to the lowest position, through the use of relative retaining pin;
- park the tractor on a dry and level surface;
- reduce the engine speed, then disengage PTO;
- wait for stopping of all rotating parts;
- lower the implement to the ground;
- set the parking brake;
- shut down the engine and remove the key before exiting the tractor;
- place safety blocks under tiller to prevent unit from tipping over onto a child and/or an adult. A tiller that tips over can result in injury or death;
- disconnect the driveline from the tractor PTO and rest it on the provided support of the tiller;
- disconnect the top link and rear lifting arms of the tractor from the tiller hitches;
- check the tiller stability. If needed, place additional safety blocks;
- get on the tractor, start the engine and move away from the tiller slowly;
- make sure the tiller remains stored in a protected area, to prevent that unauthorized personnel can approach it.

Before a long term storage (e.g. at seasonal end), do cleaning and maintenance operations as specified in Sections MAINTENANCE and STORAGE.

5.5 TRASPORTING

To set the tiller for transportation, perform the following steps:

- idle tractor engine, disengage tractor PTO, and wait for stopping of all rotating parts;
- lift the tiller until the transport position, making sure the driveline transmission tubes does not contact tractor or tiller. A minimum gap of 2 cm should be leaved between the tubes and tractor and tiller (see also Section Driveline installation);
- lock the tractor lifting hydraulics, turn off the engine, set the parking brake, remove ignition key and get off the tractor;
- adjust the parking stand to the highest position, through the use of relative retaining pin, to prevent its possible damage during transport.

When driving on public roads, follow strictly all local laws and traffic regulations.

 WARNING

When driving on public roads, reduce your speed, be aware of traffic around you and proceed in such a way that faster moving vehicles may pass you safely.

6 MAINTENANCE

Proper and regular maintenance ensures a long life of the equipment, avoids failures and saves time and repair costs.

Periodic inspections and maintenance operations described in this section must be performed by operator in the times and terms prescribed. Failure to comply with maintenance prescriptions can compromise the functioning and duration of the machine, and consequently invalidate the warranty.

The frequency of maintenance indicated refers to normal conditions of use: it must be intensified in severe operating conditions (frequent stops and starts, prolonged winter season etc ...).

Repairs, maintenance and modifications other than those mentioned in this paragraph should NOT be performed without consulting the manufacturer or your dealer. Manufacturer, as the case, may give the authorization to proceed with the repair together with all necessary instructions.

Wrong or inappropriate repairs or maintenance may generate abnormal operating conditions, equipment damage and generate risks for the operator.

WARNING

For safety reasons, all maintenance operations must be performed with tractor PTO disengaged, tiller stopped and completely lowered to the ground or onto support blocks, parking brake set, tractor engine shut off, and ignition key removed.

IMPORTANT

Respect the environment. Store or dispose of unused chemicals as specified by the chemical manufacturer.

6.1 BLADES REPLACEMENT

Frequently check the wear condition of blades through visual inspection. The wear of blades is very variable depending on the type of soil.

Replacement of the blades is necessary when the operator notices increase of power absorption during tilling, or when the blade dimension is significantly reduced compared to the original.

The use of the machine with blades in bad condition compromises the quality of work.

Before perform replacement of the blades:

- idle tractor engine, set the parking brake, disengage tractor PTO, and wait for all moving parts to come to a complete stop;
- place the tiller slightly lifted from the ground on safety blocks or mechanical stands;
- lock the control lever of the hydraulic lift of the tractor;
- turn off the tractor and remove the key.

To perform the replacement of blades:

- remove the two bolts and washers clamping the blade to the rotor flange, then remove the blade;
- position the new blade exactly instead of the worn blade, then tighten the bolts, referring to the tightening table of this manual for proper torque values. Be sure to install the blade with cutting edge in front of the direction of rotation;
- repeat the same procedure for all the other blades.

At the end of the replacement, make sure the blades have the right helical arrangement, as shown in the figure:

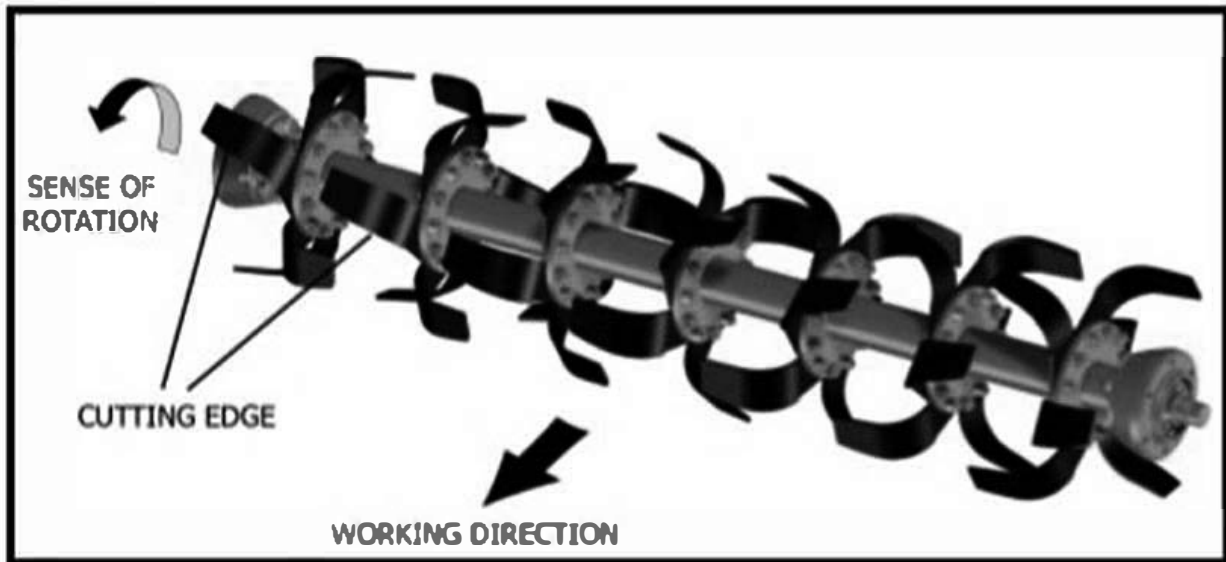

Periodically check the tightness of screws and nuts, and tighten if necessary.

IMPORTANT

Remove and install one blade at a time to ensure blades are correctly oriented when installed.
Replace worn blades only with original parts.

CAUTION

Worn tines may be very sharp!

6.2 GEARBOX LUBRICATION

Lubricant: HP 85W140 (API GL4)

Check the oil level every 50 hours, making sure the oil mark left on the dipstick of the filling plug (top of gearbox) is located between the two reference marks (minimum and maximum).

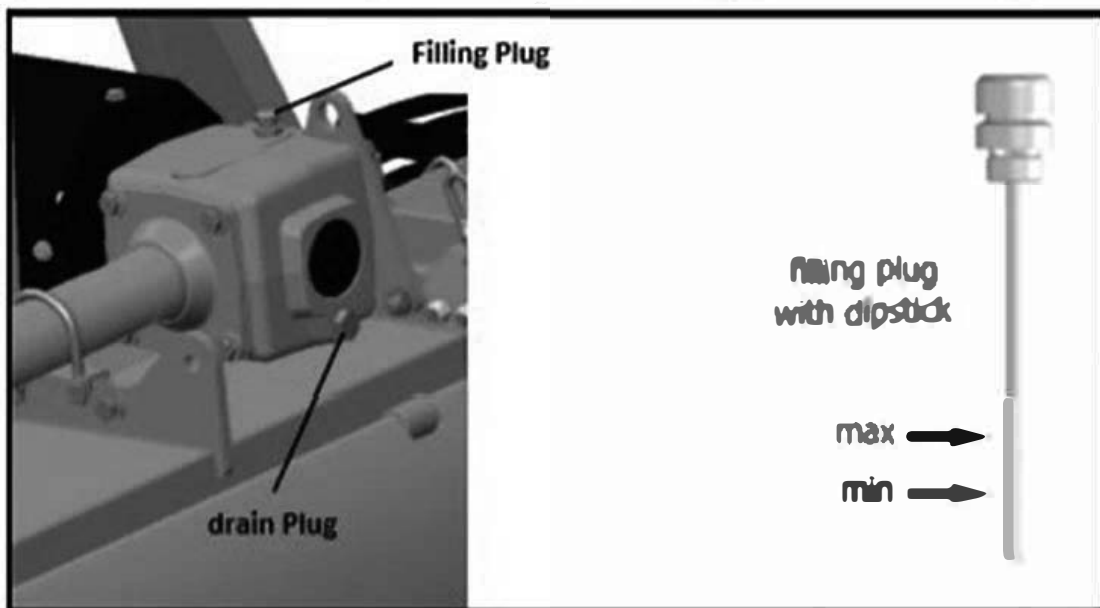

If the sign is below the minimum, fill up oil till restore the correct level.

The oil change must be performed:

- after the first 50 working hours;
- each 500 working hours.

To make the oil change:

- place a tank under the oil drain plug (bottom of gearbox);
- unscrew the oil drain plug and drain oil completely into the tank;
- retighten the drain plug;
- unscrew the oil filling plug;
- fill up oil till restoring the correct level (between the two reference dipstick marks);
- retighten the filling plug;
- dispose the discharged oil into containers for used oil.

⚠ CAUTION

Before touching the gearbox wait until it has cooled sufficiently.

IMPORTANT

Frequently check possible oil leaks from tiller through visual inspection, and in case of leakage provide immediately proper maintenance.

Avoid oil leaks on the ground when restoring oil level or making oil change.

6.3 SIDE CASE LUBRICATION

Lubricant: HP 85W140 (API GL4)

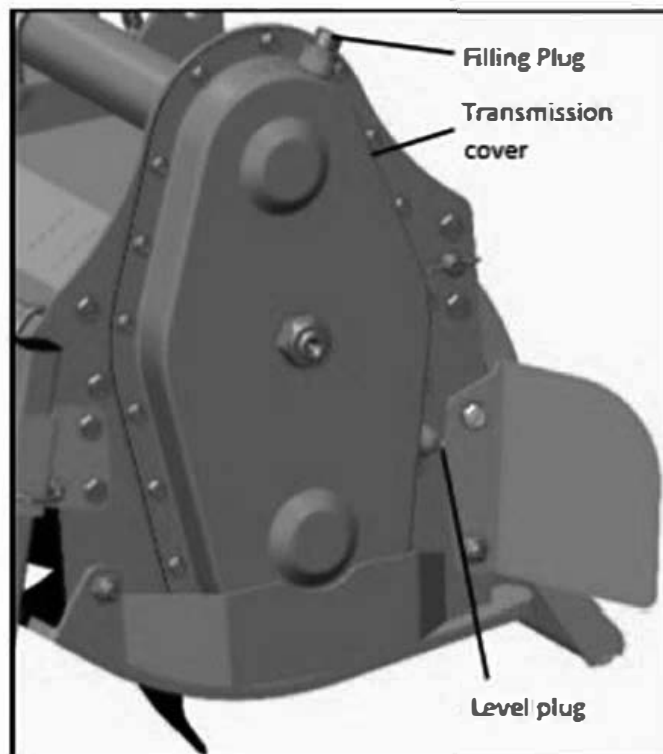

Check the oil level every 50 hours, making sure it reaches the level plug on the transmission cover.

If the oil is below this level, fill up oil till restore the level.

The oil change must be performed every 500 working hours.

To make the oil change:

- remove the skid from the transmission side;
- place a tank under the oil level plug;
- unscrew the oil level plug and drain completely the oil into the tank;
- retighten the level plug;
- unscrew the oil filling plug (top of transmission cover);
- fill up oil till restoring the correct level (until level plug);
- retighten the filling plug;
- replace the side skid;
- dispose the discharged oil into containers for used oil.

6.4 BEARING HOUSING LUBRICATION

Lubricant: SAE multi-purpose lithium-type grease

Grease the rotor hub supports every 8 working, through a suitable grease gun.

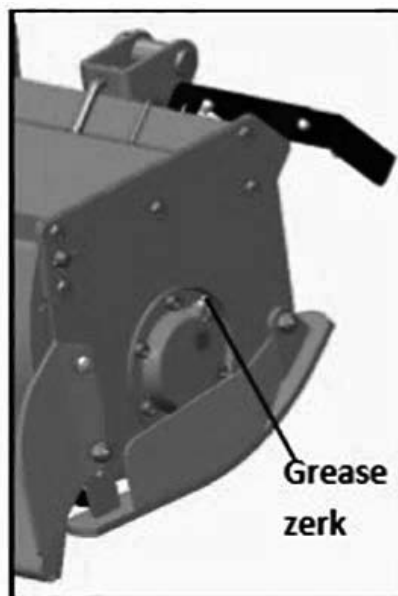

IMPORTANT

Make sure to clean the fitting zerk before using grease gun.

Do not let excess grease collect on or around parts, particularly when operating in sandy areas.

6.5 DRIVESHAFT MAINTENANCE

Lubricant: SAE multi-purpose lithium-type grease

Grease crosses, sliding parts of protective shielding and driveshaft transmission tubes.

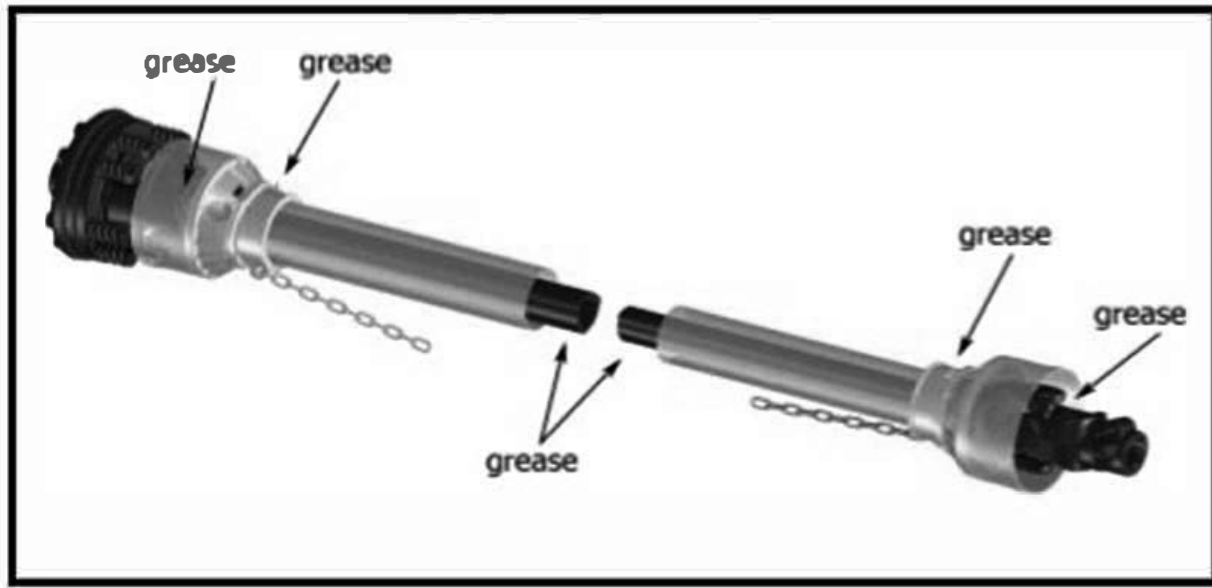

IMPORTANT

For details about maintenance and lubrication of the driveshaft, refer to the user manual of the driveshaft manufacturer.

Driveshaft clutch:

Exposition to the elements of tiller and driveshaft, or a long period of inactivity, generally results in oxidation of some clutch components, and creates "sticking" effect on the clutch.

Consequently, the torque required to the slippage of the clutch increases considerable respect to the value set at factory, and this may be cause of driveshaft breakage during operation, or damage to the tractor or implement.

To avoid it, before re-using the tiller, operator must perform a short "run-in" of the clutch, as follows:

- take note of the height of the compressed springs;
- loosen the bolts that compress the springs;
- connect the tiller to the tractor (see section Connecting to the tractor);
- connect the driveshaft (see section Driveline installation);
- start the tractor and engage PTO for few seconds, in order to cause slippage and separation of the parts "sticked" of the clutch;
- turn off the tractor, remove key and wait for all components are stopped before dismounting from tractor;
- retighten the bolts restoring the original springs position on the driveshaft.

NOTE

For replacement of the driveshaft service parts (e.g. friction discs), refer to the user manual of the driveshaft manufacturer.

7 STORAGE

Before leaving the tiller unused for a long time, it's necessary to perform following tasks to preserve the appearance and functionality of the machine, and to make easier the restart at later use:

- park the tiller on a flat surface, in a place dry and protected from exposition to the elements, possibly with storage temperature between 0 and 50 ° C (see Section Stopping and disconnection);
- thoroughly clean the machine, removing from the rotor all residues due to tillage, in order to avoid damage from grass and stagnant water;
- inspect carefully the machine, checking for worn and/or damaged parts. Perform immediately all repairs and/or replacements needed, in order to make the machine ready for restarting;
- in case of abrasion of painted surfaces, provide restoring the surface protection through touch-up paint to prevent rust;
- make sure the safety decals are in their original positions, intact and legible. When required, replace the decals immediately;
- lubricate properly all grease points, and restore the oil levels as indicated in the maintenance Section. Use protective oil to coat the exposed mechanical components and to protect them against rust.

If the tiller driveshaft is equipped with a friction clutch, it is suggested to take note of the height of the compressed springs and loosen the bolts that compress the springs, to prevent the discs from "sticking" effect due to moisture, that may cause the clutch failure at restart of the activities (see also Driveshaft maintenance).

Before restart the operations, restore the original height of the springs.

8 SCRAPPING

In case of scrapping, the machine must be disposed in appropriate and authorized sites, according to local legislation.

Before scrapping, separate plastic parts from rubber parts, aluminum, steel, etc.

Recover and dispose any exhausted oils to authorized centers for oil collecting.

9 TROUBLESHOOTING

PROBLEM	POSSIBLE CAUSE	POSSIBLE SOLUTION
Gearbox/transmission case noise noticeable and constant	Low oil level. Worn gears.	Add oil to the gearbox/transmission case. Replace gears
Intermittent noise from tiller	Loose blades. Gear tooth damaged.	Tighten blades hardware Replace damaged gear
Noise and/or vibration from tiller	Blades worn or damaged. Bearings damaged.	Replace blades. Replace bearings.

	the front of the tiller is not leveled to the back. Rotor damaged. Hard soil.	Adjust 3-point top link of tractor making tiller PTO parallel to the ground. Repair/replace rotor Reduce ground speed
Driveline vibration	Worn driveshaft. Machine lifted too high. Debris wrapped on rotor.	Replace driveshaft. Lower machine and readjust tractor lift stop. Remove debris.
Rotor stops turning	Slip clutch slipping. Broken chain in chain box.	Reduce load to tiller or adjust slip clutch. Repair broken link.
Machine skip or leaves crop residue	Badly worn blades. Slip clutch slipping. Ground speed too fast for conditions.	Replace worn blades. Adjust slip clutch or reduce load. Reduce ground speed .
Smoke and/or hot smell from tiller	Debris wrapped around in blades and/or rotor. Low oil level in gearbox. Slip clutch slipping.	Remove debris. Add oil Reduce load to machine or adjust slip clutch.
Gearbox overheating	Low oil level. Hard soil.	Add oil. Reduce ground speed.
Blades wear frequently	Muddy or sandy soil.	Reduce ground speed.
Blades break frequently	Stony soil.	Reduce ground speed.
Oil leaking from gearbox/ transmission case	Gearbox/transmission case overfilled. Loose filling/drain plug. Damaged breather plug. Damaged seals.	Drain to proper level. Tighten filling/drain plug. Replace breather plug. Replace seals.
Tillage depth insufficient	Tiller is carried by tractor. Tractor has insufficient power. Skids need adjusting. Blades worn or bent. Blades incorrectly installed. Debris entangled in blades and/or rotor.	Lower tractor 3-point arms. Increase PTO speed Adjust skids. Replace blades. Install tines correctly. Clear rotor and/or blades
Soil texture too coarse	Rear board too high. PTO speed too slow. Ground speed too fast.	Lower rear board. Increase PTO speed. Reduce ground speed.
Soil texture too fine	Rear board too low. Ground speed too slow.	Raise rear board Increase ground speed.
Tillerchoking up with soil	Blades worn or bent. Blades incorrectly installed. Rear board too low.	Replace blades. Install tines correctly. Raise rear board.

	Soil too wet.	Wait until soil dries.
Tiller skipping on ground or leaving crop residue	Blades incorrectly installed (wrong helical arrangement, cutting edge in wrong direction...) Debris entangled in blades and/or rotor. Ground speed too fast. Soil too hard.	Install blades correctly (replace right helical arrangement, position cutting edge in front of rotation direction...) Clear rotor and/or blades. Reduce ground speed. Reduce ground speed and make tilling in more steps.
Tillage not uniform	Blades worn or damaged. Skids not aligned. Tiller left side not leveled with right side.	Replace blades. Align skids. Adjust tractor 3-point arms.
Too load required to tractor	Excessive working depth . Excessive PTO speed.	Lower skids. Reduce PTO speed.

10. TORQUE VALUES TABLE

Check frequently tiller hardware to make sure that screws and bolts are tightened according to torque values listed in following table:

	8.8 GRADE	10.9 GRADE
BOLT SIZE (METRIC)	Nm	Nm
M6	10-11	14-15
M8	25-27	34-36
M10	51-54	69-73
M12	91-97	122-129
M14	137-147	185-196
M16	224-240	302-320
M18	300-321	403-428
M20	440-472	593-630

Note: The parts/material that are not covered by this warranty are as follows:

1. Blades
2. Universal joint cross
3. Paint
4. Bearings
5. Rubber parts
6. Gaskets
7. Fasteners
8. Fabrication
9. Chains & sprockets
10. Tires

12. SPARE PARTS

All repairs and replacements on the machine must be performed only by using original spare parts, which must be obtained / provided from the manufacturer or your dealer.

This section contains the information needed to identify the parts of U-series tillers that may be ordered to manufacturer.

When request spare parts to manufacturer, always give following indications:

- type of machine;
- tiller serial number;
- description and p/number of the spare parts;
- quantities.

NOTE

For identification of p/numbers and description of safety decals refer to the Section Safety labels.

For identification of p/numbers and description of PTO driveline parts, refer to the manual of the driveshaft manufacturer.

The Manufacturer reserves the right to substitute a required part with an equivalent part, if applicable.

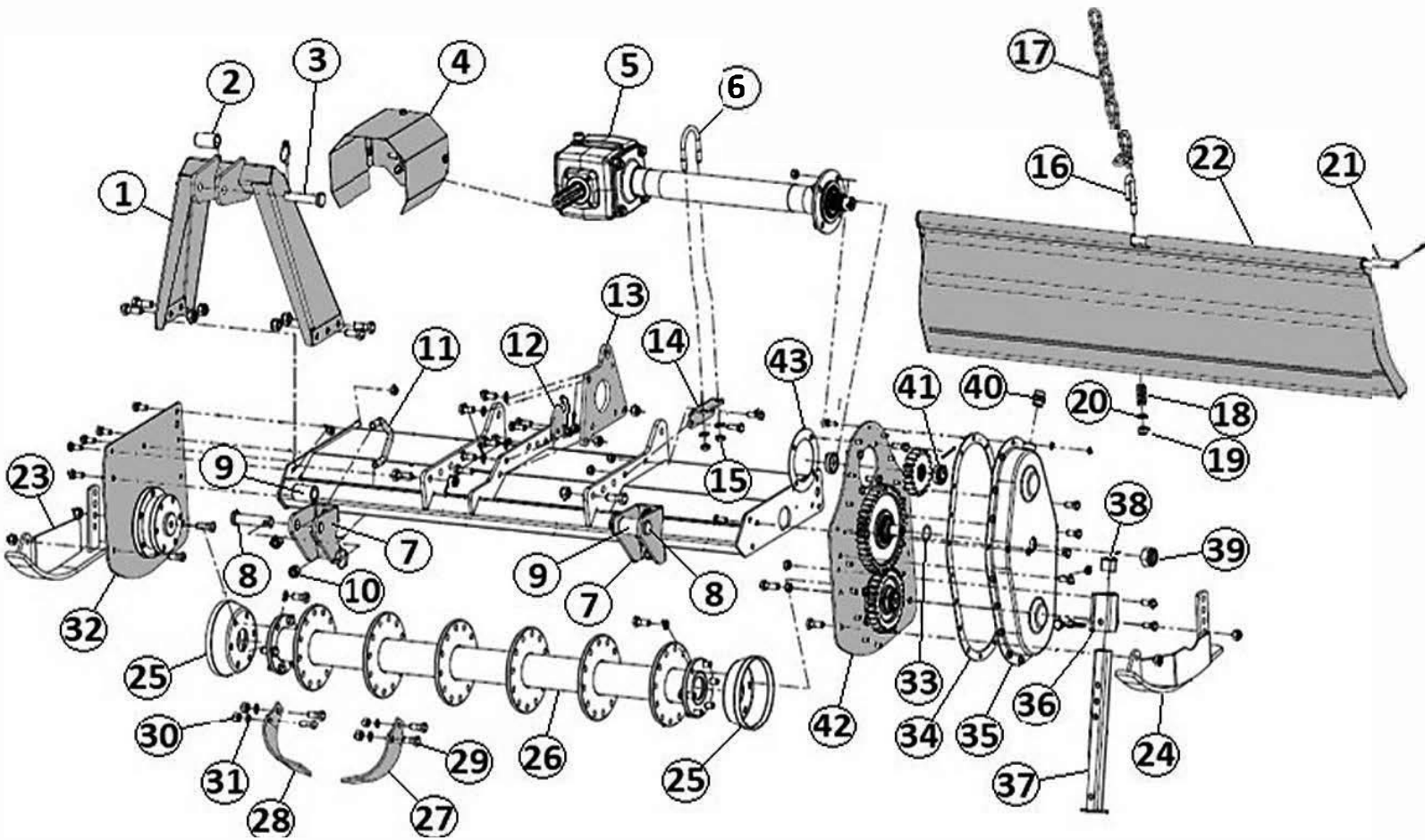

Item	Part #	Description	QTY
1	SK14239	TOP MAST	1
2	SK14038	TOP LINK BUSHING	1
3	SK14037	TOP HITCH PIN CAT-I	1
4	SK14172	PTO SHIELD	1
5	SK10211	TOP GEARBOX (48" Tiller)	1
	SK14079	TOP GEARBOX (60" Tiller)	1
6	SK14008	U-BOLT M10	1
7	SK14011	LOWER HITCH BRACKET	2
8	SK14015	LOWER HITCH PIN CAT-I	2
9	SK14016	LOWER HITCH BUSHING	2
10	SK1574	NYLOCK NUT M14 X 2	4
11	SK14014	V-BOLT M14	2
12	SK14258	CHAIN LIFT HOOK	1
13	SK14042	GEARBOX MOUNTING PLATE	1
14	SK14027	SHAFT MOUNTING PLATE	1
15	SK17272	HEX NUT M10 X 1.5	2
16	SK14004	J-BOLT M12	1
17	SK14073	TAILGATE LIFT CHAIN	1
18	SK14005	J-BOLT SPRING	1
19	SK8126	PLAIN WASHER 12mm	1
20	SK1209	NYLOCK NUT M12 X 1.75	1
21	SK10210	TAILGATE ROD (48" Tiller)	1
	SK14050	TAILGATE ROD (60" Tiller)	1
22	SK14272	TAILGATE (48" Tiller)	1
	SK14003	TAILGATE (60" Tiller)	1

Item	Part #	Description	QTY
23	SK14010	RH SKID SHOE	1
24	SK14009	LH SKID SHOE	1
25	SK14020	DUST COVER	2
26	SK10209	ROTOR (48" Tiller)	1
	SK14002	ROTOR (60" Tiller)	1
27	SK14041	LH "C" TINE (48" Tiller)	18
	SK14041	LH "C" TINE (60" Tiller)	21
28	SK14040	RH "C" TINE (48" Tiller)	18
	SK14040	RH "C" TINE (60" Tiller)	21
29	SK14324	HEX BOLT M12 X 1.25 X 30	A/R
30	SK14336	HEX NUT M12 X 1.25	A/R
31	SK14339	LOCK WASHER 12mm	A/R
32	SK14078	RH SIDE PLATE ASSY	1
33	SK14131	O-RING M30 X 3.50	1
34	SK14030	SIDE COVER GASKET	1
35	SK14007	SIDE COVER	1
36	SK14012	STAND MOUNTING BRACKET	1
37	SK14013	STAND	1
38	SK14266	SQ. PLASTIC CAP 32mm	1
39	SK14065	NYLOCK NUT M24 X 2	1
40	SK14310	BREATHER PLUG 1/2"	1
41	SK8032	CASTLE NUT 28mm	1
42	SK14077	LH SIDE PLATE ASSY	1
43	SK14031	FLANGE GASKET	1

TOP GEARBOX COMPONENTS

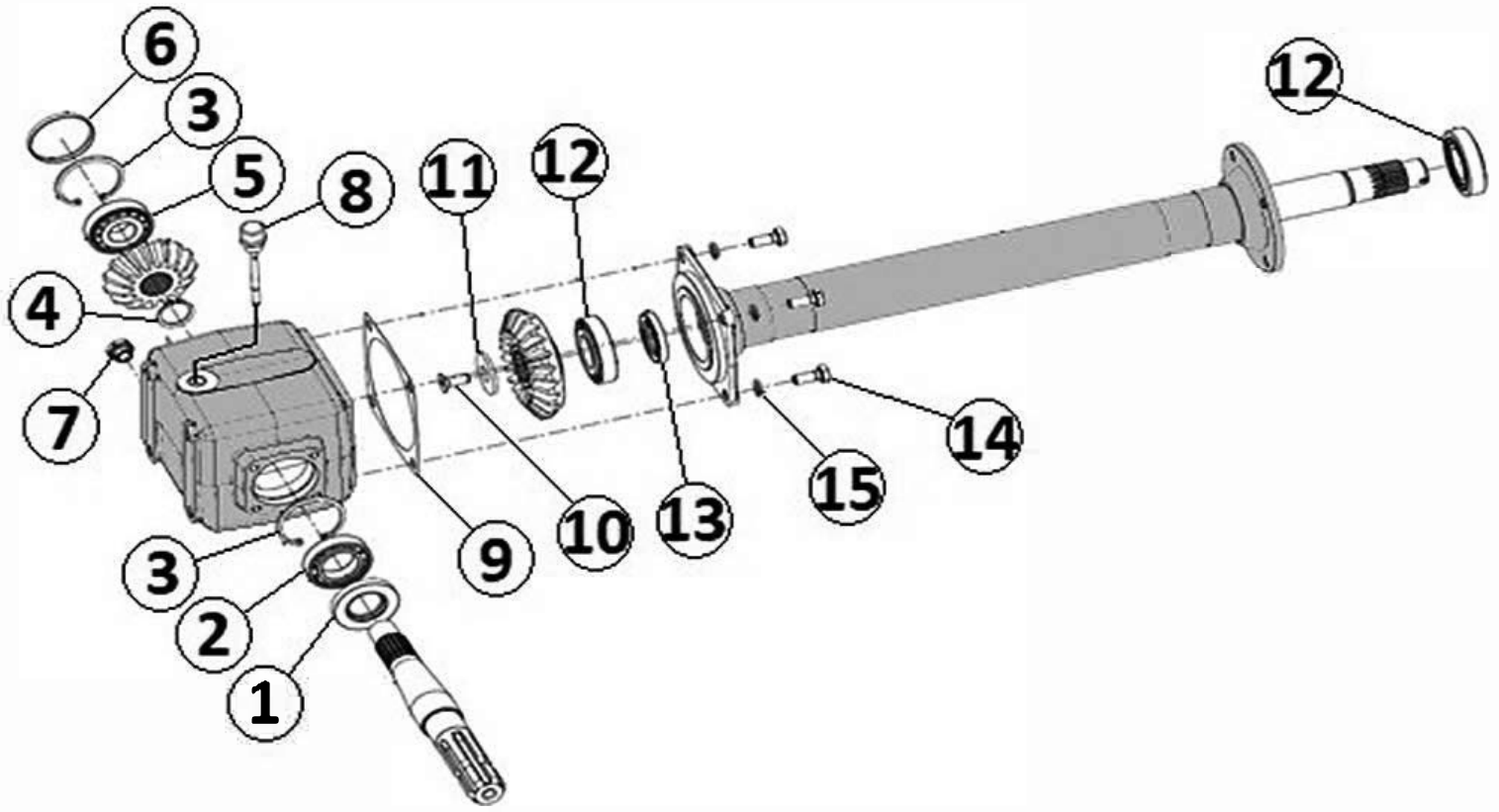

	PART #	DESCRIPTION	Qty
1	SK14057	INPUT OIL SEAL 35 X 62 X 10	1
2	SK14054	BEARING 6007	1
3	SK8120	CIRCLIP INTERNAL 62mm	2
4	SK11058	CIRCLIP EXTERNAL 30mm	1
5	SK14053	BEARING 30305	1
6	SK14075	OIL SEAL PLUG 62 X 7	1
7	SK14312	DRAIN PLUG 3/8"	1
8	SK14317	DIPSTICK BREATHER M16 X 1.5 X 90	1
9	SK14044	FLANGE GASKET	1
10	SK14058	CSK BOLT M10 X 1.5 X 25	1
11	SK14049	CROWN WASHER	1
12	SK1003	BEARING 30207	2
13	SK14056	OIL SEAL 35 X 55 X 8	1
14	SK17270	HEX BOLT M10 X 1.5 X 25 (8.8)	4
15	SK1304	LOCK WASHER 10mm	4
	SK10211	TOP GEARBOX (48" TILLER)	1
	SK14079	TOP GEARBOX (60" TILLER)	1

RH SIDE PLATE COMPONENTS

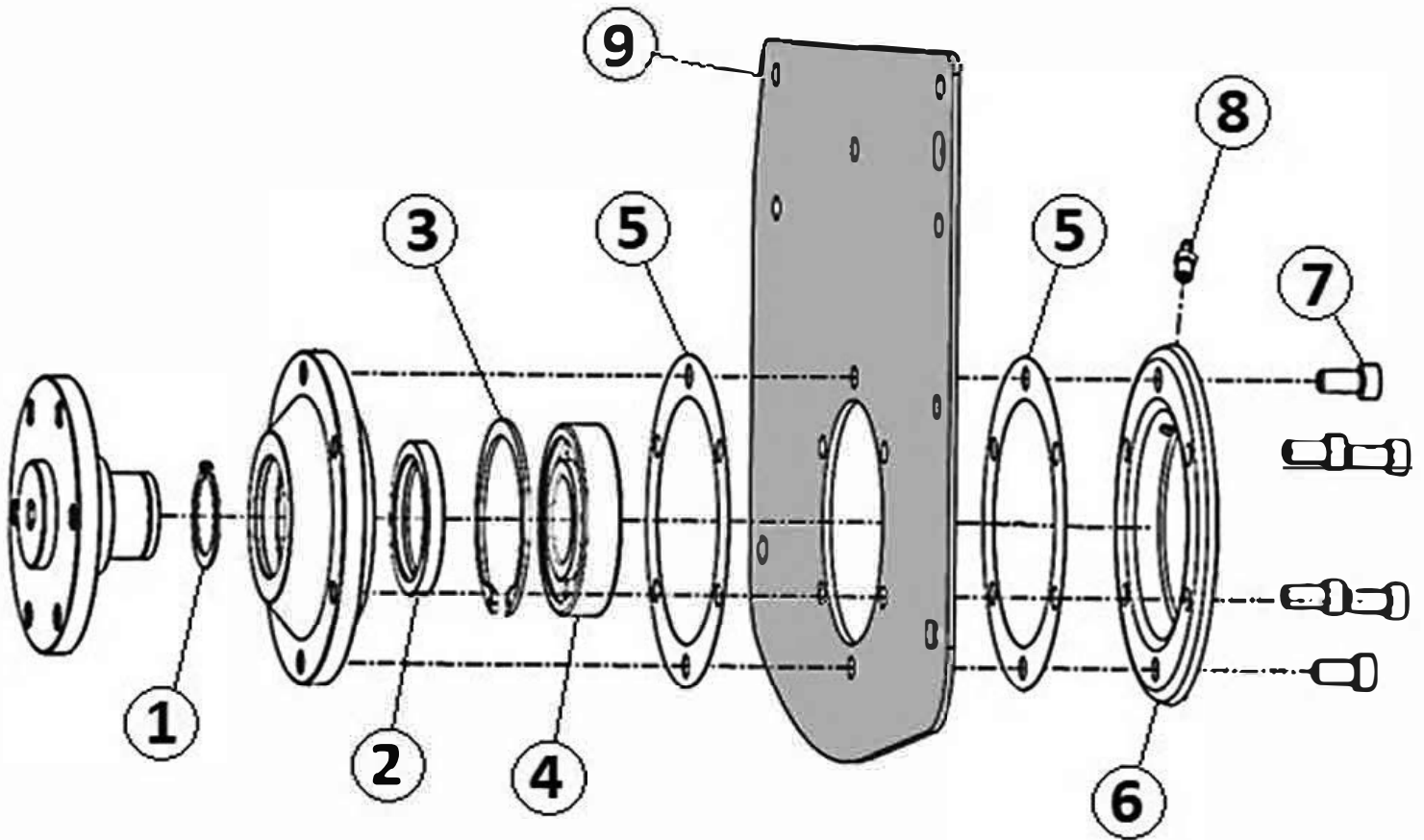

	PART #	DESCRIPTION	Qty
1	SK8027	CIRCLIP EXTERNAL 40mm	1
2	SK14051	OIL SEAL 55 X 72 X 10	1
3	SK3027	CIRCLIP INTERNAL 90mm	1
4	SK8036	BEARING 6308	1
5	SK14018	END COVER GASKET	2
6	SK14256	END COVER	1
7	SK2833	ALLEN BOLT M10 X 1.5 X 25	6
8	SK1253	1/8 GREASE ZERK 7.5mm	1
9	SK14078	COMPLETE SIDE PLATE ASSY	1

LH SIDE PLATE COMPONENTS

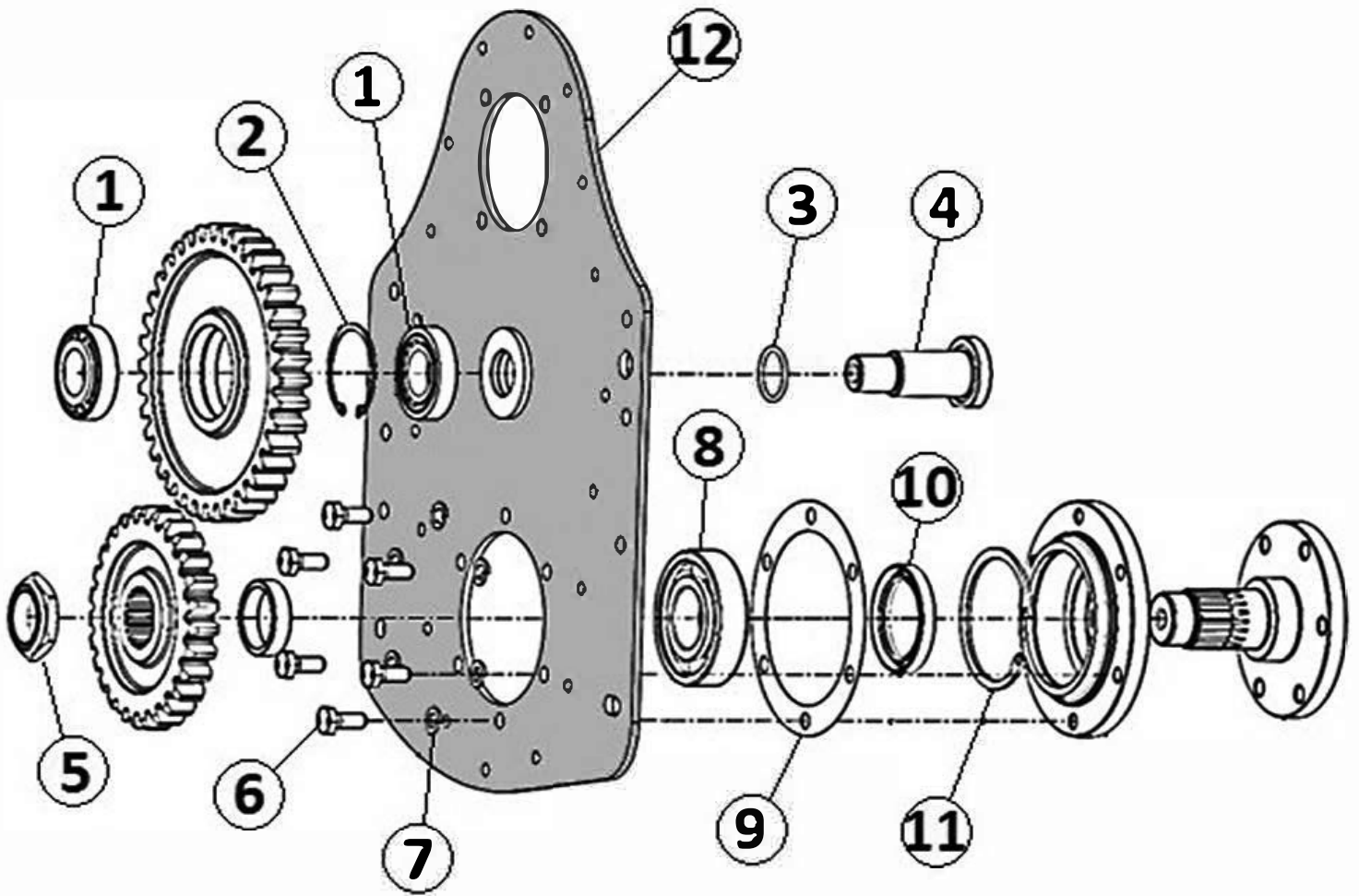

	PART #	DESCRIPTION	Qty
1	SK14055	BEARING 30206	2
2	SK8120	CIRCLIP INTERNAL 62mm	1
3	SK14131	O-RING M30 X 3.50	1
4	SK14025	STUB SHAFT	1
5	SK1449	NYLOCK NUT M35 X 1.5	1
6	SK17270	HEX BOLT M10 X 1.5 X 25 (8.8)	6
7	SK1304	LOCK WASHER 10mm	6
8	SK8036	BEARING 6308	1
9	SK14018	END COVER GASKET	1
10	SK14051	OIL SEAL 55 X 72 X 10	1
11	SK3027	CIRCLIP INTERNAL 90mm	1
12	SK14077	COMPLETE LH END PLATE ASSY	1

SLIPCLUTCH DRIVELINE COMPONENTS FITS 4' - 5' - 6' TILLER

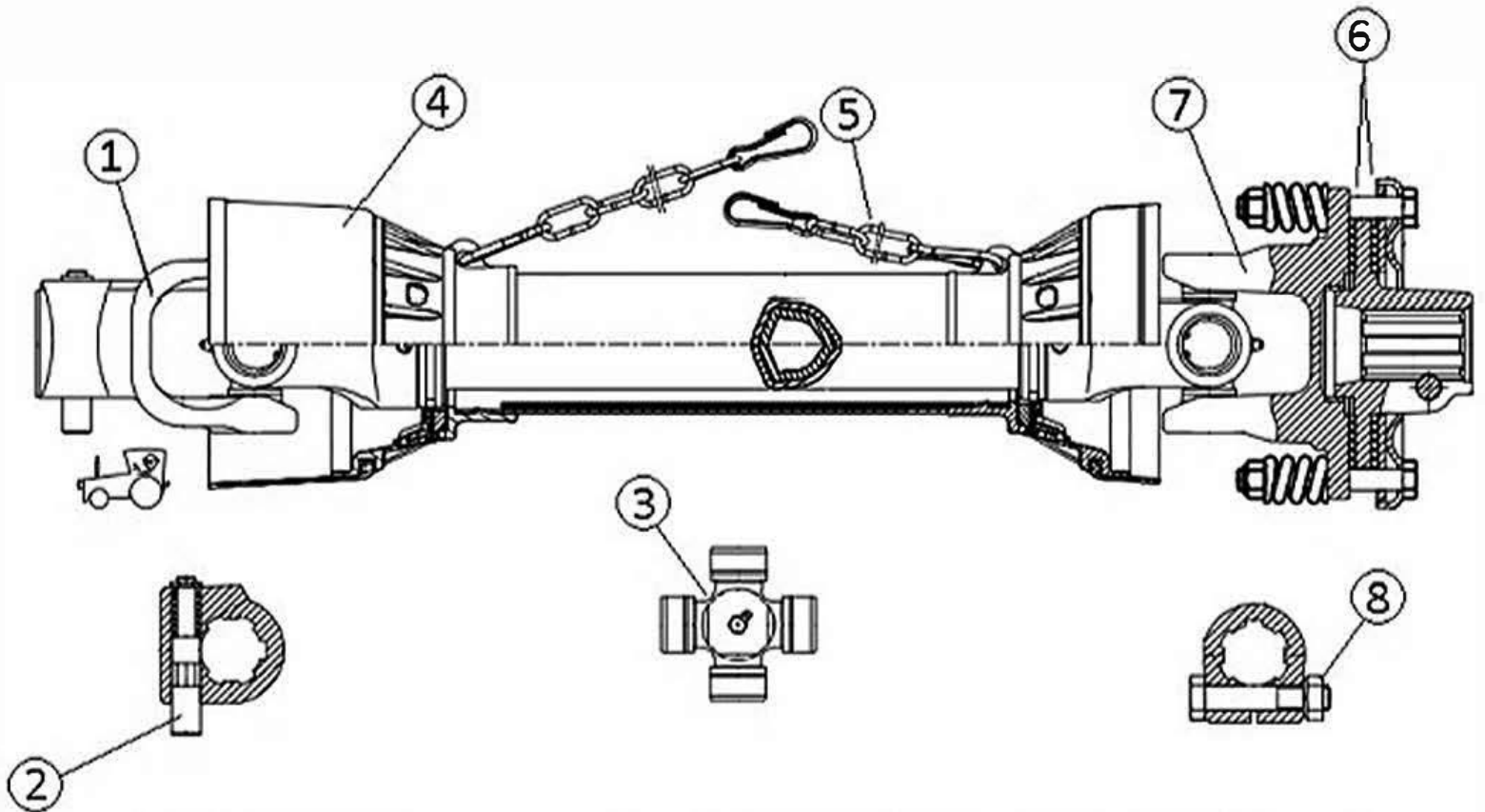

	DESCRIPTION	Item #	Qty
1	TRACTOR YOKE 1-3/8" W/PUSH PIN	552000	1
2	PUSH PIN KIT	552001	1
3	CROSS KIT	552003	1
4	OUTER PLASTIC SHIELD BRG	552008	1
5	INNER PLASTIC SHIELD BRG	552009	1
6	COMPLETE SAFETY SHIELD	552002	1
7	SAFETY SUPPORT CHAINS	552005	2
8	CLUTCH LINING (PACK OF 2)	552010	1
9	COMPLETE SLIP CLUTCH	552011	1
10	ECCENTRIC PIN KIT	552012	1
	COMPLETE SC DRIVELINE	210046	

* May need o cut to fit certain 4-FT and 5-FT tiller applications



MANUFACTURER'S LIMITED WARRANTY

BLUE DIAMOND ATTACHMENTS, a manufacturer of quality attachments, warrants new BLUE DIAMOND ATTACHMENTS products and/or attachments at the time of delivery to the original purchaser, to be free from defects in material and workmanship when properly set up and operated in accordance with the recommendations set forth by BLUE DIAMOND ATTACHMENTS, LLC.

BLUE DIAMOND ATTACHMENTS liability for any defect with respect to accepted goods shall be limited to repairing the goods at a BLUE DIAMOND ATTACHMENTS designated location or at an authorized dealer location, or replacing them, as BLUE DIAMOND ATTACHMENTS shall elect. The above shall be in accordance with BLUE DIAMOND ATTACHMENTS warranty adjustment policies. BLUE DIAMOND ATTACHMENTS obligation shall terminate twenty four (24) months after the Rototiller delivery of the goods to original purchaser.

This warranty shall not apply to any machine or attachment which shall have been repaired or altered outside the BLUE DIAMOND ATTACHMENTS factory or authorized BLUE DIAMOND ATTACHMENTS dealership or in any way so as in BLUE DIAMOND ATTACHMENTS judgment, to affect its stability or reliability, nor which has been subject to misuse, negligence or accident beyond the Company recommended machine rated capacity.

WARRANTY CLAIM

To submit a warranty claim, a return authorization from BLUE DIAMOND ATTACHMENTS must be obtained. The failed part may then be returned. Tampering with the failed part may void the warranty. This warranty does not include freight or delivery charges incurred when returning machinery for servicing. Dealer mileage, service calls, and pickup/delivery charges are the customers' responsibility.

EXCLUSIONS OF WARRANTY

Except as otherwise expressly stated herein, BLUE DIAMOND ATTACHMENTS makes no representation or warranty of any kind, expressed or implied, AND MAKES NO WARRANTY OF MERCHANTABILITY IN RESPECT TO ITS MACHINERY AND/OR ATTACHMENTS ARE FIT FOR ANY PARTICULAR PURPOSE. BLUE DIAMOND ATTACHMENTS shall not be liable for incidental or consequential damages for any breach or warranty, including but not limited to inconvenience, rental of replacement equipment, loss of profits or other commercial loss. Upon purchase, the buyer assumes all liability for all personal injury and property resulting from the handling, possession, or use of the goods by the buyer.

No agent, employee, or representative of BLUE DIAMOND ATTACHMENTS has any authority to bind BLUE DIAMOND ATTACHMENTS to any affirmation, representation, or warranty concerning its machinery and/or attachments except as specifically set forth herein.

This warranty policy supersedes any previous documents.

NOTE: Blue Diamond Attachments is a trademark of BLUE DIAMOND ATTACHMENTS, LLC.



QUALITY | DEPENDABILITY | INTEGRITY

Blue Diamond® Attachments
4512 Anderson Road, Knoxville, TN 37918
88-376-7027