

# ROCK & CONCRETE GRINDER

## Operation and Maintenance Manual



- 159010 - G1S
- 159015 - G1
- 159020 - G2
- 159025 - G3
- 159030 - G3XL
- 159035 - G4



*Register your  
WARRANTY  
within 30 days  
of purchase*



BD-092



888-376-7027 | [BlueDiamondAttachments.com](http://BlueDiamondAttachments.com)

Blue Diamond Attachments®

## Owner Information

Thank you for your decision to purchase a Blue Diamond Rock & Concrete Grinder. To ensure maximum performance of your equipment, it is mandatory that you thoroughly study the Operator's Manual and follow the recommendations. Proper operation and maintenance are essential to maximize equipment life and prevent personal injury.

Operate and maintain this equipment in a safe manner and in accordance with all applicable local, state, and federal codes, regulations and /or laws. Follow all on-product labeling and instructions.

Make sure that all personnel have read this Operator's Manual and thoroughly understand safe and correct operating, installation and maintenance procedures.

Blue Diamond is continually working to improve its products. Blue Diamond reserves the right to make any improvements or changes as deemed practical and possible without incurring any responsibility or obligation to make any changes or additions to equipment sold previously.

Although great care has been taken to ensure the accuracy of this publication, Blue Diamond makes no warranty or guarantee of any kind, written or expressed, implied or otherwise with regard to the information contained within this manual. Blue Diamond assumes no responsibility for any errors that may appear in this manual and shall not be liable under any circumstances for incidental, consequential or punitive damages in connection with, or arising from the use of this manual.

Keep this manual available for frequent reference. All new operators or owners must review the manual before using the equipment and annually thereafter. Contact your Blue Diamond Attachments Dealer for assistance, information, or additional copies of the manual. Contact [www.bluediamondattachments.com](http://www.bluediamondattachments.com) or call 888-376-7027 for a complete list of dealers in your area.

## Serial Number Location

Please record attachment information in the space provided for future reference.



**Model Number:** \_\_\_\_\_

**Serial Number:** \_\_\_\_\_

**Dealer Name:** \_\_\_\_\_

**Dealer Number:** \_\_\_\_\_

**Date of Purchase:** \_\_\_\_\_

The serial number plate (is located on right side, just forward of the attachment mounting plate.

Always use your serial number when requesting information or when ordering parts.

**NOTE:** The directions left, right, front and rear, as mentioned throughout this manual, are as viewed from the operator's position.

## TABLE OF CONTENTS

1. GENERAL INFORMATION . . . . .	4
2. SAFETY . . . . .	5
2.1 General Safety Instructions . . . . .	6
2.2 Operator Responsibilities. . . . .	9
2.3 Personal Protective Equipment. . . . .	10
2.4 rock and concrete Cutter Decals . . . . .	11
3. TECHNICAL DATA . . . . .	12
3.1 Weight . . . . .	12
3.2 Excavator Weight Ratio . . . . .	13
3.3 Operating Parameters . . . . .	13
3.4 Hydraulic Operating Parameters . . . . .	13
3.5 Hydraulic Performance . . . . .	15
3.6 Maximum Compression Strength (Rock) . . . . .	15
3.7 Overview . . . . .	16
4. INSTALLATION AND START-UP . . . . .	16
4.1 Hydraulic Excavator Minimum Requirements . . . . .	17
4.2 Mounting . . . . .	17
4.2.1 Quick Coupler . . . . .	18
4.3 Hydraulic Installation . . . . .	18
4.3.1 Case Drain Line . . . . .	20
4.4 Initial Startup . . . . .	20
4.4.1 Checks during initial operation . . . . .	20
4.5 Remove Ginder . . . . .	20
5. OPERATION . . . . .	21
5.1 Lifting Eye . . . . .	22
5.2 Emergency Shutdown . . . . .	23
5.3 Before Use . . . . .	23
5.3.1 Bits . . . . .	23
5.3.2 Pedestal (If Equipped) . . . . .	24
5.3.3 Main Housing . . . . .	24
5.3.4 Hydraulic Motor . . . . .	24
5.3.5 Hydraulic Hoses and Connectors . . . . .	24
5.4 Operating Instructions . . . . .	24
5.4.1 Switching On . . . . .	24
5.4.2 Working with rock and concrete Cutter . . . . .	25
5.4.3 Switching Off . . . . .	26
5.4.4 After Use . . . . .	26
5.4.5 Cleaning . . . . .	26
5.4.6 General Inspection . . . . .	27

5.5 Rotating Grinder (Pedestals Only) . . . . .	27
6. MAINTENANCE . . . . .	27
6.1 Maintenance Safety . . . . .	28
6.2 Unauthorized Maintenance . . . . .	28
6.3 Maintenance Intervals . . . . .	28
6.3.1 Daily Maintenance. . . . .	28
6.4. Lubrication. . . . .	29
6.4.1 Oil Specifications . . . . .	29
6.4.2 Oil Capacity. . . . .	30
6.4.3 Oil Change Interval . . . . .	30
6.4.4 Change Gear Oil . . . . .	30
6.5 Replace Bits . . . . .	31
6.5.1 Retaining Ring Type . . . . .	31
6.5.2 Clamping Ring Type . . . . .	31
6.5.3 Clamping Sleeve Type . . . . .	32
6.5.4 Safety Warning . . . . .	32
6.5.5 Standard Retaining Clip Type. . . . .	33
6.5.6 Snap Ring .Type . . . . .	33
6.5.7 Quick Snap Type. . . . .	34
6.6 Replace Cutter Heads . . . . .	35
6.6.1 Remove Cutter Heads . . . . .	35
6.6.2 Install Cutter Heads . . . . .	35
6.7 Pedestal (If Equipped . . . . .	35
6.7.1 Disassemble Pedestal . . . . .	35
6.7.2 Assemble Pedestal . . . . .	36
6.8 Replace Hydraulic Hoses . . . . .	36
6.9 Remove Dust and Contamination . . . . .	36
6.10 After Maintenance Inspections . . . . .	36
7. TROUBLESHOOTING . . . . .	37
8. STORAGE AND TRANSPORT . . . . .	40
8.1 Transport Inspection . . . . .	40
8.2 Packaging . . . . .	40
8.3 Transport . . . . .	40
8.3.1 Crane or Hoist . . . . .	40
8.3.2 Forklift . . . . .	41
8.4 Storage . . . . .	41
8.4.1 Cutter Heads . . . . .	42
8.4.2 Bits . . . . .	42
HYDRAULIC SCHEMATIC . . . . .	43
TORQUE TABLES . . . . .	44
PARTS ASSEMBLY . . . . .	47-54
WARRANTY . . . . .	55

## 2. SAFETY

It is the responsibility of the user to read and understand the Operator Manual in regards to safety, operation, lubrication and maintenance before operation of this equipment. It is the user's responsibility to inspect and service the machine routinely as directed in the Operator Manual.

We have attempted to cover all areas of safety, operation, lubrication and maintenance; however, there may be times when special care must be taken to fit your conditions.

Throughout this manual the symbol  and the words **DANGER**, **WARNING**, and **CAUTION** are used to call attention to safety information that if not followed, will or could result in death or injury. **NOTICE** and **NOTE** are used to call your attention to important information.

The definition of each of these terms follows:



**DANGER** Indicates a hazardous situation which, if not avoided, will result in death or serious injury.



**WARNING** Indicates a hazardous situation which, if not avoided, could result in death or serious injury.



**CAUTION**, used with the safety alert symbol, indicates a hazardous situation which, if not avoided, could result in minor or moderate injury.



**NOTICE** is used to address practices not related to personal injury.



**NOTE:** Special point of information or machine adjustment instructions.

## 2.1 GENERAL SAFETY INSTRUCTIONS

1. Read and understand instructions provided in this manual and warning labels. Review these instructions frequently!
2. Never allow equipment to be operated by anyone unfamiliar with operation of all functions of the unit. Operators must read and thoroughly understand all instructions given in this manual before operating or working on equipment.
3. Make sure equipment weight does not exceed capacity of prime mover or exceed combined equipment bridge and road limits. This is critical to maintain safe control and prevent death, injury, property and equipment damage.
4. Always wear protective clothing, shoes, gloves, hearing and eye protection as applicable.
5. Prevent electrocution, other injuries, property and equipment damage. Watch for obstructions such as wires, tree limbs, etc. when operating equipment. Be aware of clearances during turns and when moving equipment.
6. Reinstall all covers removed for maintenance activities. Covers are required during operation.
7. Use professional help if you are unfamiliar with working on hydraulic systems. Pressurized hydraulic fluid can penetrate body tissue and cause death, serious infection, or other injuries.
8. The machine is designed and built for mounting on a hydraulic excavator and other hydraulic carriers. Other uses are only approved by written agreement with Blue Diamond Corporation.
9. The grinder is designed to cut:
  - Rock
  - Asphalt
  - Reinforced and non-reinforced concrete
  - Frozen ground
  - Ice
  - Wood
  - Soil remediation
  - Numerous other specialty applications exist. Contact Blue Diamond for additional information.

**NOTE:** Always refer to hydraulic excavator operating manual when operating or working on the grinder.

**NOTE:** Check compressive strength of rock when cutting with the grinder.

## **WARNING**

Misuse of rock and concrete cutting grinder head or excavator can cause death, serious injury and damage to property and equipment.

- Do not use grinder in areas at risk of explosion.
- Do not cut any materials other than those listed in Section 2.1, # 9.
- Do not perform impacting operations.
- Do not operate machine with any broken bits.
- Do not use machine for lifting personnel or materials.
- Do not use grinder to carry or transport machinery, materials or tools.
- Do not use grinder to take weight of carrier vehicle.

## **WARNING**

Hydraulic excavator exhaust can cause death or serious injury if not properly vented.

- Properly vent exhaust gasses from buildings or tunnels using a ventilation system.
- Keep cabin doors closed on the hydraulic excavator.

## **WARNING**

Lightning strikes during thunder storms can cause death or serious injury.

- Do not operate machine during thunderstorms.
- Do not work on machine or stay in hydraulic excavator during thunder storms.
- Do not remain within 330 feet (100 meters) of hydraulic excavator after a lightning strike.

## **CAUTION**

High noise levels can cause hearing loss. Always use hearing protection and stay away from hazardous work area.

## **WARNING**

Rotating equipment, parts, and machine motion can cause death or serious injury.

- Always keep a safe distance of 50 feet (15 meters) when grinder is operating.
- Do not reach into or touch moving parts.
- Do not open covers on grinder during operation.
- Wear close fitting clothes with minimal tear strength when working in hazardous area.

## **CAUTION**

Severe vibration can cause injury, chronic health conditions, or damage to equipment.

- Operate machine with a constant load to minimize vibrations.
- Avoid sudden starting or stopping of cutting heads.

## **WARNING**

High pressure hydraulic fluid leaks can cause death, loss of body parts or serious injury.

- Never place body parts or objects in hydraulic flow areas. Administer first aid and seek medical attention immediately if contact with hydraulic fluid under pressure occurs.
- Activate emergency stop immediately. Perform additional steps to reduce pressure and stop jet of hydraulic fluid.
- Contain hydraulic fluid and dispose of properly.
- Repair damaged or defective parts immediately.

## **WARNING**

Hydraulic powered moving parts can cause death or serious injury.

- Allow only qualified and trained personnel to work on hydraulic systems.
- Depressurize hydraulic system before performing any maintenance or repairs. Completely depressurize hydraulic accumulator.
- Do not reach into or touch moving parts during operation.
- Do not open covers on rock and concrete cutter during operation.
- Wear close fitting clothes with minimal tear strength when working in hazardous area.

## **CAUTION**

Cutter heads become very hot during operation and can cause severe burns.

- Wear heat resistant gloves and clothing when working near hot surfaces.
- Make sure all grinder surfaces are cool before working on machine.

## **CAUTION**

Inhaled dust can cause lung damage or other illnesses. Harmful dust can be produced from material cut during operation.

- Wear light respiratory protection when working near operating machine.
- Keep doors of excavator closed during operation.

## **WARNING**

Inoperative safety devices can cause death, serious injury and damage to property and equipment.

- Check all safety devices are operating properly before starting work.
- Never turn off or disable safety devices.
- Make sure all safety devices are readily accessible.
- Refer to hydraulic excavator manual for safety device operating instructions.



# NOTICE

Improper handling and disposal of environmentally harmful substances can cause damage to the environment.

## 2.2 OPERATOR RESPONSIBILITIES

### WARNING

Allowing unqualified and untrained personnel to operate, perform maintenance, or work in vicinity of machine can result in death, serious injury and/or damage to property and equipment.

- Only allow qualified personnel to perform any work.
- Keep unqualified personnel away from hazardous areas of machine.
- Stop work if any unqualified or unauthorized persons are in hazardous areas.

An Operator is the person who operates the machine for commercial or financial purposes or whom commissions a third party to operate the machine and bears legal product responsibility for the Health and Safety protection of the user, personnel or third parties during its operation.

1. Machine is used in commercial applications. Operator is subject to all legal obligations pertaining to industrial safety.
2. In addition to the safety instructions contained in this manual, follow all required safety, accident prevention and environmental regulations.
3. Know applicable industrial safety regulations and determine any additional risks specific to working conditions at the job site. These risks should be recorded in a Risk Assessment and comply with instructions contained in this manual.
4. Check all operating instructions are current in accordance with the latest regulations and adjust when necessary.
5. Regulate and designate responsibilities for installation, removal, operation, troubleshooting, maintenance and cleaning.
6. Ensure all personnel read and understand this manual. Train personnel every six months and maintain training records for future accountability.
7. Required Personal Protection Equipment (PPE) is available and personnel are instructed to use them.
8. Hazardous areas in direct vicinity of machine are secured against access before operating machine.
9. Attach a sign to hydraulic excavator boom instructing personnel to wear

hearing protection.

10. Check all safety equipment regularly for functionality and completeness.
11. Suitable protection measures are implemented in the event of severe dust (e.g. water sprinkling or use of dust protection masks).
12. Ensure carrier vehicle is suitable for connection with the rock and concrete cutter.
13. Hydraulic oil must not enter the environment. Hydraulic oil can have long term damaging effects once in the water system. Disposal must be carried out by a hazardous material disposal company.

## 2.3 PERSONAL PROTECTIVE EQUIPMENT

Personal Protective Equipment (PPE) protects personnel against dangers which may affect their health or safety during work. Follow instructions PPE posted in the work area.



### **Protective Work Clothing**

Tight-fitting work clothing with low resistance to tearing, tight sleeves and without projecting parts. It primarily protects against entanglement by moving machine parts. Do not wear rings, chains or other jewelry.



### **Hearing Protection**

Protects against hearing damage.



### **Light Respiratory Protection**

Protection from hazardous dusts.



### **Protective Goggles**

Protects eyes from flying debris, dust and fluids.



### **Protective Gloves**

Protects hands from friction, abrasion, puncture wounds, burns or more serious injuries.



### Safety Helmet

Protection from falling and flying parts and materials.



### Safety Footwear

Protection from heavy falling parts and prevents slipping on slippery surfaces.

## 2.4 rock and concrete CUTTER DECALS

### **WARNING**

Illegible decals and symbols can result in failure to recognize hazards and can cause death, serious injury or damage to property and equipment. Labels and signs can become dirty or illegible from wear or other causes.

- Keep all safety, maintenance and operating instructions highly legible at all times.
- Replace damaged labels and signs immediately.

Location of grinder decals are shown in the following illustration:

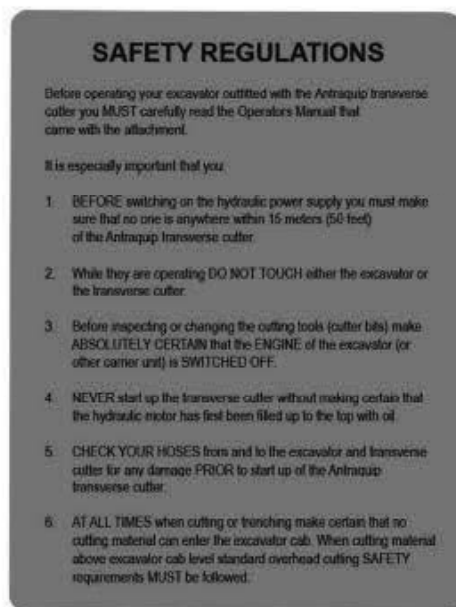

### SAFETY REGULATIONS

Before operating your excavator fitted with the Blue Diamond Grinder you MUST read the Operators Manual that came with the attachment. It is especially important that:

1. BEFORE switching on hydraulic power supply make sure no one is within 50 feet (15 meters) of the Blue Diamond Grinder.

2. DO NOT TOUCH the excavator or grinder when they are operating.
3. Before inspecting or changing cutter bits make ABSOLUTELY CERTAIN the ENGINE of the excavator (or other carrier unit) is SWITCHED OFF.
4. NEVER start grinder without making certain the hydraulic motor is filled with oil as per procedures in grinder Operator's Manual.
5. CHECK HYDRAULIC HOSES to and from the excavator and grinder for any damage before startup of the grinder.
6. AT ALL TIMES when cutting or trenching make certain no cutting material can enter the excavator cab. Standard overhead cutting SAFETY requirements MUST be followed when cutting above excavator cab.

### 3. TECHNICAL DATA

#### 3.1 WEIGHT

MODEL	WEIGHT (lbs)	WEIGHT (Kg)
159010 - GS1	265	120
159015 - G1	635	290
159020 - G2	1,035	470
159025 - G3	2,045	930
159030 - G3XL	2,290	1.040
159035 - G4	4,125	1.875

### 3.2 EXCAVATOR WEIGHT RATIO

MODEL	WEIGHT (ton)
159010 - GS1	1 - 3
159015 - G1	2 - 8
159020 - G2	5 - 15
159025 - G3	12 - 20
159030 - G3XL	15-28
159035 - G4	25-45

### 3.3 OPERATING PARAMETERS

AMBIENT TEMPERATURE RANGE	MAXIMUM TIME OF OPERATION
-13 to +122° F (-25 to +50° C)	24 Hours Continuous

### 3.4 HYDRAULIC OPERATING PARAMETERS

MODEL	GPM	L/m
GS1-1	5 - 8	19 - 30
GS1-2	6 - 12	22 - 45
G1-2	10 - 18.5	40 - 70
G1-3	13 - 21	50 - 80

### 3.4 HYDRAULIC OPERATING PARAMETERS (continued)

MODEL	GPM	L/m
G1-4	16 - 24	60 - 90
G2-2	13 - 24	50 - 90
G2-3	16 - 26	60 - 100
G2-4	18 - 26	70 - 100
G3-1	32 - 45	120 - 170
G3-2	34 - 45	130 - 170
G3XL-1	32-48	120-180
G3XL-2	40-53	150-200
G3XL-3	45-58	170-220
G4-1	53-85	200-320
G4-2	64-85	240-320
G4-3	66-85	250-320

### 3.5 HYDRAULIC PERFORMANCE

MODEL	HP	Kw
G1S	24	20
G1	40	30
G2	60	45
G3	90	65
G3XL	120	90
G4	160	120

### 3.6 MAXIMUM COMPRESSION STRENGTH (ROCK)

**NOTE:** Contact Blue Diamond before cutting reinforced concrete.

MODEL	PSI	MPa
G1S	5,076	35
G1	5,800	40
G2	7,300	50
G3	9,400	65
G3XL	11,600	80
G4	14,500	100

### 3.7 OVERVIEW

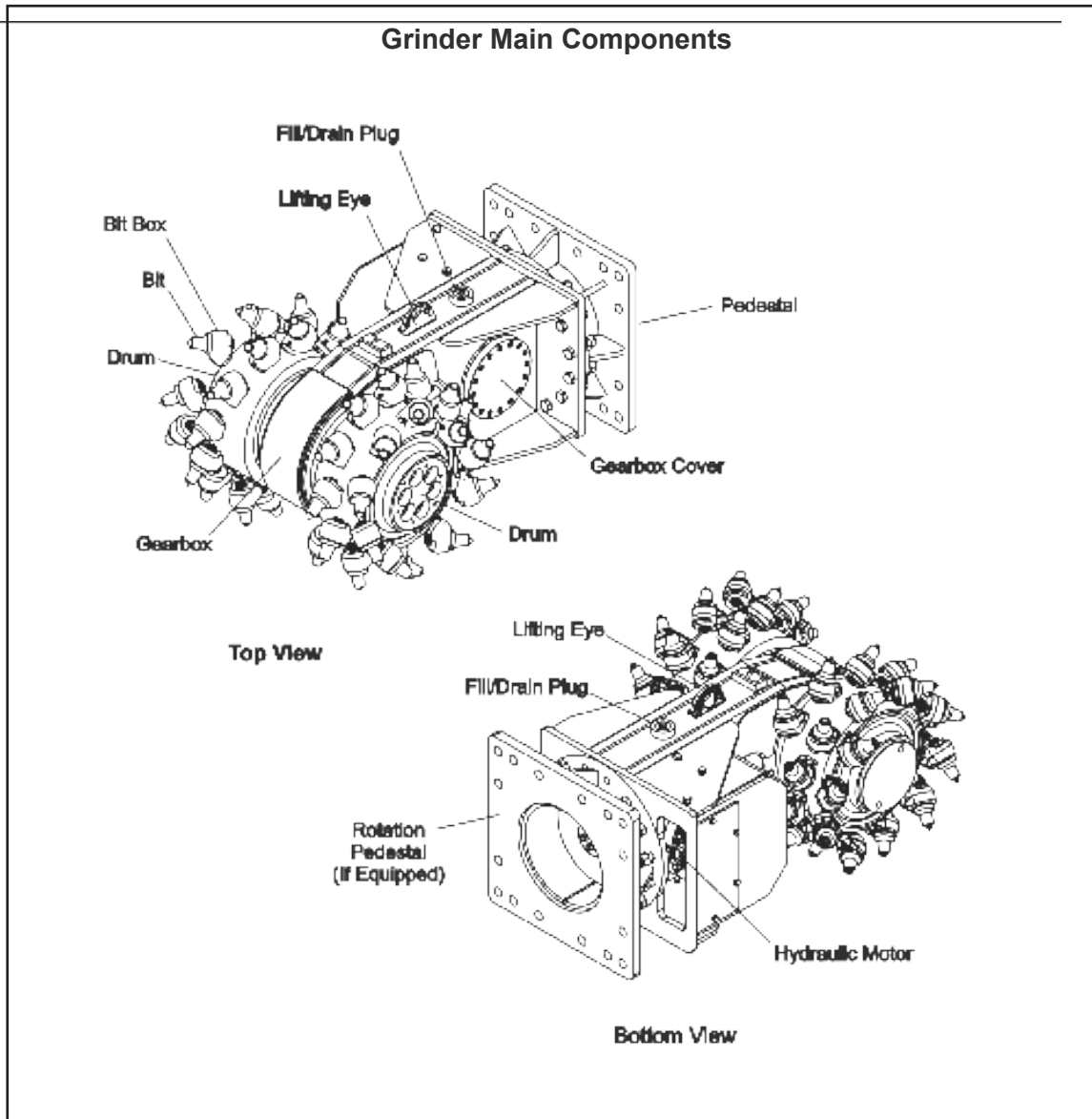

### 4. INSTALLATION AND STARTUP

	<p><b>! WARNING</b></p> <p>Improper installation and start-up can cause death, serious injury, or damage to property and equipment. Only allow authorized personnel to install and perform initial startup of machine.</p>
---	--



## 4.1 HYDRAULIC EXCAVATOR MINIMUM REQUIREMENTS

### **NOTICE**

Failure to meet basic hydraulic excavator specifications for the specific model grinder can cause serious damage to equipment. Make sure hydraulic excavator is suitable for attaching your model of rock and concrete cutter.

1. Complete hydraulic hammer or shear line running to end of excavator arm.
2. Motor high-pressure supply line set to maximum 350 bar.
3. Return line pressure minimum 72 psi (5 bar) above case drain pressure.
4. Case drain pressure maximum 43 psi (3 bar) during operation.
5. Excavator cab protected against flying debris.
6. Excavator must provide adequate view of work area.
7. Minimum 14 Lumens/sq-ft (150 Lux) protected lighting.
8. E-Stop functional at operating and driving positions highly recommended.
9. Audible warning signal.
10. All controls at operating and driving positions should have a “dead man’s” switch.
11. All replacement parts must meet OEM specifications.

### **! WARNING**

**Old parts can fail and cause death, serious injury and/or damage to property and equipment. Never reuse old parts. Use only original equipment parts.**

## 4.2 MOUNTING

The grinder is supplied with a pedestal for mounting to a quick-coupler or adapter plate. Mating areas of connector plates must be flat and smooth (Roughness Ra 12.5 max – surface deviation 0.5 mm).



## 4.2.1 QUICK COUPLER

**NOTE:** Refer to hydraulic excavator operating manual for installing quick coupler to excavator.

1. Mount quick coupling to hydraulic excavator.
2. Attach quick coupler adapter plate to excavator arm.
3. Set drum cutter on assembly stand.
4. Guide excavator arm and adapter plate to drum cutter.
5. Place excavator arm with adapter plate on pedestal bracket of rock and concrete cutter. Line up bolt holes.
6. Prevent adapter plate and pedestal from sliding with two mandrels.
7. Switch the hydraulic excavator off and safeguard against being switched on again.
8. Install two bolts. Do not tighten.
9. Remove mandrels.
10. Install remaining bolts.
11. Tighten all bolts in an alternate horizontal pattern.

**Note:** Refer to Torque Tables in back of this manual.

## 4.3 HYDRAULIC INSTALLATION

### **WARNING**

Incorrect installation of hydraulic circuit can cause death, serious injury and/or damage to property and equipment.

- Only allow qualified personnel to work on hydraulic systems.
- Fully depressurize hydraulic system and hydraulic accumulators before working on hydraulic system.
- Make sure work area is clear and environment is clean.
- Wear close fitting clothes with minimum tear strength and all proper Personal Protective Equipment.
- Always install hydraulic hoses with protection against mechanical or thermal damage.

The grinder is supplied with three pre-installed hydraulic hoses: Return, Case Drain and Pressure.

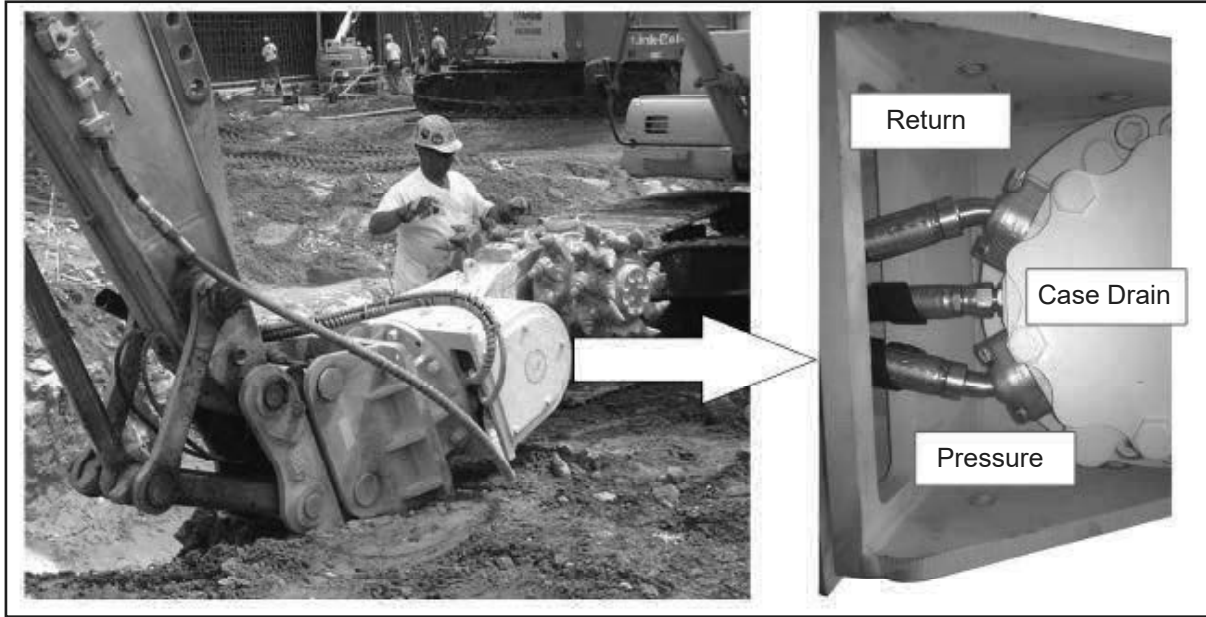

**Hydraulic Installation**

**Notice:** Installation of hydraulic circuit for operating grinder on the excavator is the responsibility of the operator. Refer to hydraulic excavator operating manual for safety and installation requirements.

1. Clean area around ball valve (left side) on excavator arm.
2. Remove end cap from ball valve.
3. Unscrew end cap from supply hose.
4. Attach supply hose to ball valve fitting. Tighten nut.
5. Clean area around ball valve (right side) on the excavator arm.
6. Remove end cap from ball valve of excavator arm

## **NOTICE**

Removing check valve from return line of hydraulic hammer systems will cause catastrophic grinder hydraulic motor failure. Never remove return line check valve on hydraulic hammer systems.

1. Unscrew end cap for return hose.
2. Attach return hose to ball valve on the opposite side to supply hose. Tighten nut.
3. Position oil receiver tank beneath case drain line of grinder
4. Fill hydraulic oil using a funnel until it overflows into case drain line.
5. Connect and screw case drain hose from grinder on separate drain line on hydraulic excavator.

### 4.3.1 CASE DRAIN LINE

A separate case drain line including oil filter must be installed from the ball valve on the excavator arm to the excavator hydraulic tank. Operator must install a suitable connection on excavator hydraulic tank for the case drain line.

1. Install a separate case drain line along the excavator arm and secure with cable ties.
2. Connect case drain line with oil filter to connection on the hydraulic tank of the excavator vehicle.
3. Attach case drain line to connection on the oil tank on hydraulic excavator.
4. Install case drain oil filter at an appropriate location on case drain line.

**Note: Failure to install separate case drain filter may cause damage to the hydraulic excavator.**

### 4.4 INITIAL STARTUP

**Note:** Adjustments to hydraulic flow and pressure settings on the excavator are the responsibility of the operator.

1. Check all fastenings, hoses and couplings.
2. Check the hydraulic oil level and shut-off valves.
3. Check all hydraulic connections for leaks/tightness.
4. Switch on motor.
5. Bring motor slowly up to normal operating conditions (oil volume and oil pressure).

#### 4.4.1 CHECKS DURING INITIAL OPERATION

- All hydraulic connections are leak tight.
- Pressure in case drain line (maximum 3 bar in constant operation).
- Oil temperature (target value 50 degree Celsius to 80 degrees Celsius).

### 4.5 REMOVE rock and concrete CUTTER

## **NOTICE**

**Hydraulic system contamination can damage equipment. Never leave hydraulic ports open. Always plug hydraulic ports and hoses when not in use.**

1. Position grinder on stand.
2. Loosen quick coupling device from excavator arm.
3. Switch off hydraulic excavator and safeguard against it being switched on again.
4. Depressurize entire hydraulic circuit.

5. Secure grinder on assembly stand.
6. Position oil receiver tank beneath the hydraulic fittings.
7. Unscrew grinder case drain line from hydraulic excavator case drain line.
8. Install end caps on lines.
9. Unscrew return hose from the valve fittings.
10. Install end caps onto the openings of the loosened lines.
11. Unscrew supply lines from ball valve fitting on excavator upright.
12. Screw end caps on lines.
13. Store disassembled grinder protected against damage.

## 5. OPERATION



- Make sure maintenance schedule has been followed before operating machine.
- Only trained personnel may maintain and operate the machine.
- Operate controls smoothly without jerking. If cutting unit stalls, back off cutter from work face. Do not overload cutter bits. Machine can be damaged.
- Cutting conditions are best if cutting heads move toward the carrier vehicle. If unit moves sideways to achieve a larger cutting area, ensure pressure on excavator's boom, arm and cutting head bearing is not excessive.
- Periodically check cutting unit is clear of debris. This can affect cutting rate.
- Ensure cutting unit or any part of unit is correctly attached during any maintenance work.

## NOTICE

- Do not operate cutting unit at end of excavator hydraulic cylinder stroke.
- Do not use cutting head with damaged or missing bits. Vibration will damage unit or excavator.
- Do not run cutter head in reverse.
- Do not cut while tracking excavator. This may damage unit.
- Do not place cutting unit against working surface before starting. This may damage unit. Unit should be running and fed into working surface at a rate that does not allow stalling.

## 5.1 LIFTING EYE



**Note:** Lifting device must move freely within the lifting eye. When lifting device (sling chains) are hinged or unhinged; no pinching, shearing or joint spots must occur during handling.

Inspect the following before each initial operation, at regular intervals, after assembly and after special incidents:

- Material worn to wear indicators (if equipped).
- Lifting point completely intact
- Deformation at load bearing components such as base body
- Mechanical damage, like strong notches, especially in areas where tensile stress occurs
- Reduction of cross-section due to wear >10 %
- Corrosion (Pitting)
- Cracks
- Cracks or other damage at weld seam
- Avoid damage from sharp edges on lifting devices.

**Note:** Some grinder lifting eyes may not have wear indicators. Check for obvious wear and thickness reduction of lifting eye.

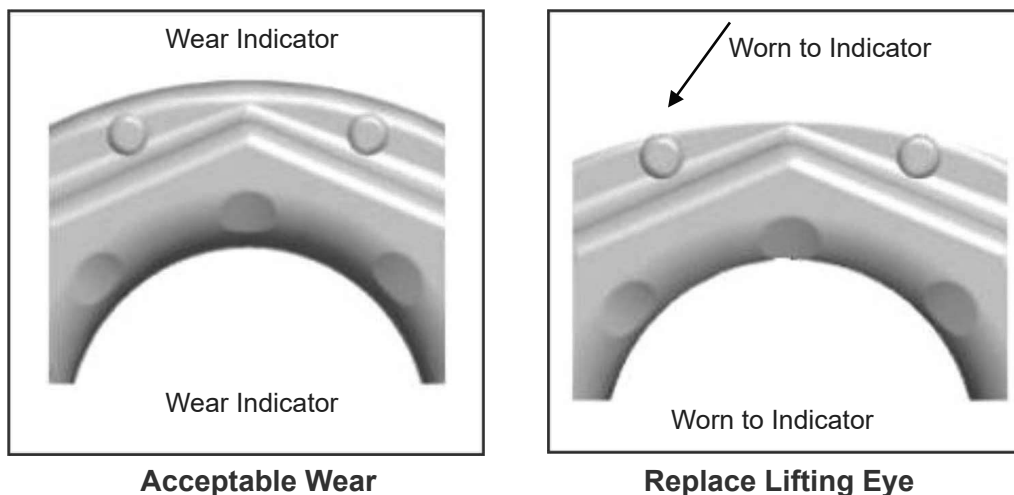

## 5.2 EMERGENCY SHUTDOWN

In hazardous situations moving parts must be stopped as quickly as possible and power supply switched off.

1. Press emergency stop device in excavator.
2. If no danger to personal safety exists, remove other persons from hazardous area. Start first-aid if needed.
3. Call 911 or nearest emergency services.
4. Inform responsible parties at work site.
5. Switch off emergency stop and secure against being switched on again.
6. Keep access routes clear for rescue vehicles.
7. Inform proper authorities depending on seriousness of emergency situation.
8. Perform troubleshooting.
9. Check machine before restart and ensure all safety devices are installed and functional.

## 5.3 BEFORE USE

Always perform the following before using the grinder to prolong service life and maintain productivity.

### 5.3.1 BITS

## NOTICE

**Unevenly worn bits can cause excessive vibration and damage equipment. Make sure bits are evenly worn.**

Bits wear at different rates depending on material cut . A particularly high wear rate should be expected with:

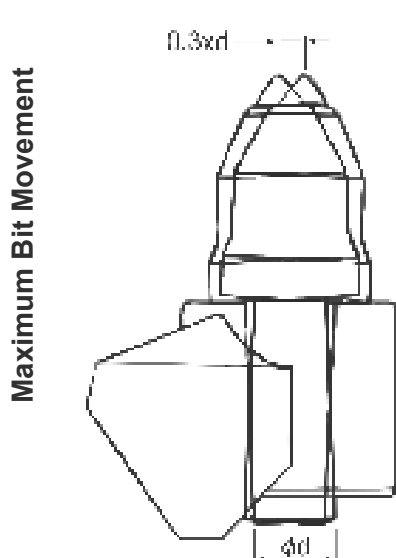

- Reinforced concrete
  - Rock with a high SiO<sub>2</sub> content, when using spray water
  - Hard rock such as granite, basalt
1. Check for wear and breakage.
  2. Replace worn or damaged bits immediately.
  3. Check for movement of bits in the bit blocks. If any bit has a play of more than 0.3 times bit shaft diameter, replace bit block or wear sleeve immediately.

**Note:** Wear sleeve and bit block replacement should only be done by Blue Diamond.

### **5.3.2 PEDESTAL (If Equipped)**

1. Check bolts are tight.
2. Check for cracks and damage.

### **5.3.3 MAIN HOUSING**

1. Check for cracks.
2. Check main housing for oil leaks.
3. Check bolts are installed and tight.

### **5.3.4 HYDRAULIC MOTOR**

1. Check hydraulic motor for oil leaks.
2. Check bolts are installed and tight.

### **5.3.5 HYDRAULIC HOSES AND CONNECTORS**

1. Check hydraulic hoses for oil leaks, damage or worn areas.
2. Check hydraulic connections for oil leaks and tightness.
3. Check case drain line for contamination. Clean as needed.

## **5.4 OPERATING INSTRUCTIONS**

- Never exceed cutting material maximum compressive strength.
- Do not activate grinder when loading excavator.
- When working with grinder, never fully extend or retract the jib lifting cylinder.
- Only switch on grinder in a raised position without contacting cutting material.
- Apply rock and concrete cutter to cutting material slowly to prevent stalling.
- When cutting, always apply rock and concrete cutter slowly and ensure cutter heads do not stop rotating.
- Do not apply excessive force during lateral cutting with excavator arm extended.
- Never switch grinder on or off when working at full capacity.
- Hydraulic oil temperature must not exceed 144° F (80° C). Check hydraulic oil temperature regularly when grinder is operating for long periods of time.

### **5.4.1 SWITCHING ON**

1. Switch on hydraulic excavator.
2. Raise grinder.
3. Start hydraulic motor for grinder.



## 5.4.2 Working with Grinder

### CAUTION

Lateral cutting movements can cause extreme vibration and hydraulic excavator instability resulting in serious injury and/or damage to equipment and property.

- Do not expose hydraulic excavator to strong forces.
- Ensure hydraulic excavator keeps constant contact with ground during cutting operations.
- Make cutting movements slowly.
- Never start or stop grinder in contact with cutting material.

When cutting proceed as follows:

1. Raise grinder.
2. Switch on grinder and start up.
3. Slowly lower the rotating cutting heads onto the cutting material.
4. Slowly apply cutting heads and ensure cutting heads are not blocked.
5. Make cutting movements towards carrier vehicle or in both directions.
6. Make cutting movements in a horizontal or vertical direction. When making lateral cuts with the hydraulic excavator jib, do not exert excessive force to the hydraulic excavator

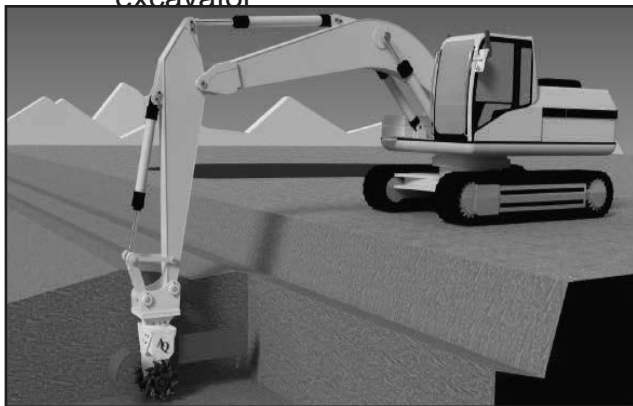

**Trenching - Move Toward Excavator**



**Vertical Cutting - Move Down Face**

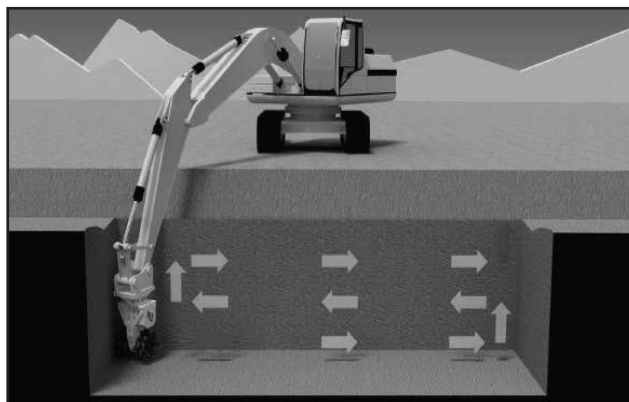

**Side-to-Side Cutting Pattern**

### 5.4.3 Switching Off

#### **NOTICE**

Switching off machine in contact with material can cause severe vibrations and damage equipment. Switch off drum cutter only in a raised position.

1. Raise lifting cylinder of jib until grinder is above ground level and is no longer in contact with cutting material.
2. Switch off hydraulic motor.
4. Lower grinder.
5. Switch off hydraulic excavator.

### 5.4.4 After Use

#### **WARNING**

Working with damaged parts can cause death, serious injury and/or damage to property and equipment.

- Conduct regular visual inspections after use.
- Replace damaged or worn parts immediately.
- Tighten all loose connections.
- Eliminate oil leaks immediately.
- Replace worn or damaged hydraulic hoses.

### 5.4.5 Cleaning

#### **CAUTION**

Improper cleaning procedures can cause serious injury and damage to equipment.

- Never hit bits, cutting heads or gears with a hard object (i.e. hammer) to free them of trapped fragments or contamination.
- Do not damage safety labels with high pressure water jets.

#### **NOTICE**

Make sure no residual contaminates such as concrete are left between bit and bit blocks. Contaminates could harden set bits in bit boxes.

Clean grinder cutting head daily after use and check all parts for damage.

1. Areas to which safety stickers are adhered should be wiped clean using a cloth.

2. Clean all the other areas of the grinder head thoroughly with water.
3. Free up the intermediate spaces between the round attack bits and bit blocks from contaminants.

### 5.4.6 General Inspection

- Check all threaded connections are tight.
- Check all hydraulic connections for leaks.
- Check all cutting heads for even wear.
- Check hydraulic hoses for damage or leaks.

### 5.5 Rotating rock and concrete Cutter (Pedestals Only)

#### **NOTICE**

Rotating grinder creates higher force to the hydraulic excavator and can damage equipment if operated improperly. rock and concrete cutter component wear increases when working at an angle.

When carrying out certain works (e.g. tunnel boring) with the grinder, it may be necessary to mount it at an angle on the hydraulic excavator.

1. Ensure grinder head is connected to hydraulic excavator in accordance with specifications.
2. Position grinder carefully on ground in a vertical position.
3. Loosen nuts and bolts on pedestal.
4. Slowly lift hydraulic excavator jib until grinder is suspended slightly above ground.
5. Turn grinder in desired direction.
6. Fix grinder in required position with nuts and bolts.
7. Slowly lower grinder to ground.
8. Bolt intermediate bracket back together with grinder and torque to specifications.
9. Tighten jam nuts.

**Note:** Refer to Torque Tables in the back of this manual.

## 6. Maintenance

### **WARNING**

Old parts can fail which can cause death, serious injury and/or damage to property and equipment. Never reuse old parts. Use only original equipment parts.

## 6.1 Maintenance Safety

Maintenance will be performed only by authorized and trained maintenance personnel.

## 6.2 Unauthorized Maintenance

Some maintenance activities must be done only by a service partner approved by Blue Diamond. If such maintenance is required, contact dealer to ensure they are done safely.

**NOTE:** The following maintenance activities are NOT authorized:

- Gear repairs
- Replacing wear sleeves and bit blocks
- Welding on cutter heads
- Welding on gear housing

## 6.3 Maintenance Intervals

Maintenance is necessary for optimum and fault free machine operation. Maintenance preserves the value and safety of the rock and concrete cutter. Routine maintenance will prevent unplanned down time and help serve to aid safe work with the grinder.

**NOTE:** If regular checks reveal a rapid wear rate, increase frequency of maintenance to match actual wear rate.

### 6.3.1 Daily Maintenance

ITEM	INSPECTION	ACTION
Bit Blocks	Play in bit blocks allows movement of more than 0.3 times diameter of shaft or bearing surface is worn.	Replace
Bits	Tungsten carbide tip worn Bits are different lengths Cracks present between shaft and head	Replace
Cutter Heads	Bearing surfaces of bit blocks are worn Bit blocks worn in snap ring area Bit blocks broken Charging spiral cannot be repaired	Replace
Gear Housing Wear Plates	Plate thickness less than 3 mm. Weld seams cracked, deformed, or damaged.	Replace

### 6.3.1 Daily Maintenance (continued)

ITEM	INSPECTION	ACTION
Hydraulic Hoses	Outer layer damaged. Brittle or deformed. Hose fitting deformed or damaged. Fitting does not stay tight. Six years or older.	Replace

### 6.4 Lubrication

Gear oil is critical for service life of the gears. It is also important to use the correct type and quantity of gear oil for the grinder.

#### 6.4.1 Oil Specifications

MANUFACTURER	TEMPERATURE RANGE	
	-4 to 86 F (-20 to 30 C)	-15 to +40 C
ARAL	EP 80 Degol BG68	EP 90 Degol BG 68
BP	EP SAE 80 Energol GR XP 68	EP SAE 90 Energol GR XP 220
EXXON/ESSO	GPD 80 Spartan EP 100	GPD 90 Spartan EP 220
MOBIL	Mobil Gear 80 EP Mobilube GX 80	Mobil Gear GX 90 Mobilube GX 90
SHELL	Spirax 80 EP Omala Oil 100	Spirax 90 EP Omala Oil 220
TEXACO	Meropa 68 Universal Gear Lubricant EP 80	Meropa 220 Universal Gear Lubricant EP 90

## 6.4.2 Oil Capacity

MODEL	G1S	G1	G2	G3	G3XL	G4
Gal	.63	1.5	2.6	4	4.75	8
L	2.4	5	10	15	18	30

## 6.4.3 Oil Change Interval

OPERATING CONDITIONS	1st Interval	2nd Interval	FOLLOWING INTERVALS
Normal Cutting	200 Hours	2000 Hours	Every 2000 Hours
Heavy Cutting (Reinforced Concrete, etc.)	100 Hours	1000 Hours	Every 1000 Hours

## 6.4.4 Change Gear Oil

### CAUTION

Failure to provide proper clearance when moving grinder to perform oil change can cause serious injury and damage to property and equipment. Always check clearances before lifting or moving grinder.

### CAUTION

Removing oil fill or drain plug without relieving gear case pressure can cause severe injuries.

- Depressurize entire hydraulic system and lockout against restart before performing maintenance on grinder.
- Slowly loosen oil fill and drain plugs and wait for pressure to drop before completely removing plugs.
  1. Position grinder horizontally on assembly stand.
  2. Lock out and tag power to grinder.
  3. Place waste oil container under oil drain plug (1).
  4. Loosen oil fill plug (2) and bleed off any pressure.

**NOTE:** Remove oil fill plug first to allow oil to drain more quickly and efficiently. Oil drain plug is on opposite side.

5. Remove oil fill plug.
6. Remove oil drain plug.
7. Allow oil to completely drain.

**NOTE:** Oil drain and fill plugs are fitted with a magnet to attract metal filings.

8. Clean oil drain plug and clean opening.
9. Check oil drain plug for metal filings, remove if necessary.
10. Install oil drain plug.
11. Clean oil filler opening with clean cloth.

## **NOTICE**

Low oil level can damage equipment and cause equipment failure. Place grinder in a vertical position (cutting heads down) and fill oil level into oil fill plug opening. Always check system is properly filled when installed on excavator.

12. Reposition grinder with cutting heads down. Fill gear oil per specifications.
13. Clean oil filler opening and fill plug.
14. Reinstall oil fill plug.
15. Clean grinder
16. Dispose of used oil in accordance with the applicable environmental regulations.

## **6.5 Replace Bits**

### **6.5.1 Retaining Ring Type**

1. Remove retaining rings from bit shaft in turn using long nose pliers.
2. Pull bits out of the bit block.
3. Clean dirt from block.
4. Insert new bit.
5. Place a new retaining ring on bit shaft and rotate retaining ring opening down.
6. Attach second retaining ring and rotate retaining ring opening up.

### **6.5.2 Clamping Ring Type**

1. Place striking iron with semi-circular opening on clamping ring opening.
2. Strike clamping ring with a forceful impact.
3. Pull round shank chisel out of chisel bracket.
4. Clean dirt from bit block.
5. Insert new bit.
6. Place new clamping ring in striking iron.

## 6.5.2 Clamping Ring Type (continued)

7. Place striking iron with clamping ring on bit shaft.
8. Strike clamping ring on striking iron with forceful impact.

## 6.5.3 Clamping Sleeve Type

1. Slide open end of chisel taper key in notch in bit with impact surface pressing on surface of bit block.
2. Grip chisel taper key firmly.
3. Hit chisel taper key impact surface with a hammer.
4. Pull bit from bit block.
5. Clean dirt from bit block.
6. Place new bit in notch of chisel taper key. Tip of bit must point in direction of impact surface.
7. Place new bit in chisel taper key and place in opening of bit block.
8. Give impact surface of the chisel taper key a forceful strike with a hammer.
9. Bit is anchored in bit block by shaft clamping sleeve.

## 6.5.4 Safety Warnings



Manufacturer is concerned with the safe use of its products. See product brochures for more detailed safety information. Follow approved safety procedures. Wear all approved personal protective equipment. To avoid personal injury or damage to tools, tines, and blades, please follow these guidelines:

- A. Wear approved personal protective equipment, including eye protection.
- B. Make sure tools, tines, and blades are properly seated and securely retained.
- C. Do not strike tools, tines, and blades with metal objects. Carbide tips could shatter. Use recommended hand tool to set bit, and bit puller to remove bit.
- D. Exercise care in removing tools. They may be hot and the flange on the long retainer may be sharp.
- E. Inspect tools before each application. If they are dull, cracked, or burred do not use them.
- F. Operate all machines with hand lowered. To avoid injury by flying debris, stay clear of machines when hoods are raised.
- G. Grinding of product produces potentially hazardous dust/mist that can irritate skin, eyes, nose, throat and cause temporary or permanent respiratory disease.



Permanent respiratory disease can lead to disability or death. Use local ventilation and respiratory protection when grinding. Avoid breathing of and prolonged skin contact with dust/mist. Maintain dust levels below OSHA and ACGIH levels. Wash hands after handling and prior to eating or smoking. Dispose of materials according to local, state and/or federal regulations.

### 6.5.5 Standard Retaining Clip Type

1. Place tool against open side of retaining clip.

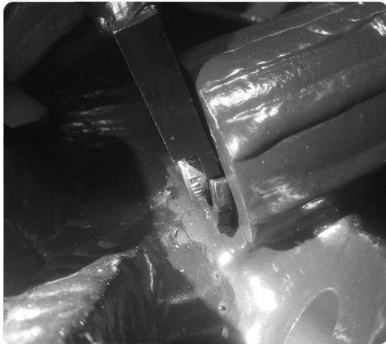

2. Strike the flat end of the tool firmly to dislodge clip.
3. Remove bit from block.
4. Clean dirt from bit block.
5. Slide new bit into block.
6. Set clip into tool and position the clip on retaining groove.



7. Firmly strike tool, snapping clip into place.

### 6.5.6 Snap Ring Type

1. Using provided tool expand first snap ring and remove over shank.



2. Repeat for second snap ring.
3. Remove bit from block.
4. Clean dirt from bit block.
5. Slide new bit into bit block.
6. Using provided tool, expand new clips and position in the retaining groove.

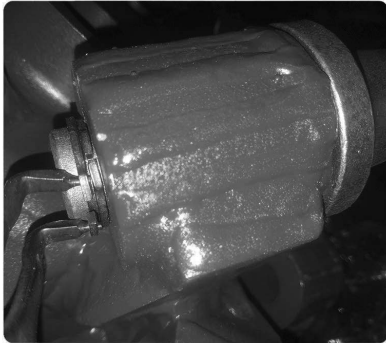

**Note:** Do not over expand clips and ensure both are fully seated in groove.

### 6.5.7 Quick Snap Ring Type

1. Place curved tip of draw hook in quick snap ring hole.
2. Grip draw arrow firmly and pull upwards.

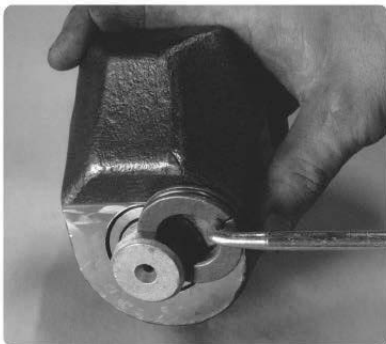

3. Remove bit from block.



4. Clean dirt from bit block.
5. Slide new bit in bit block.
6. Position new quick snap ring with opening facing down on shaft of the round attack bit and apply firm pressure until clip snaps in place.

## 6.6 Replace Cutter Heads

### 6.6.1 Remove Cutter Heads

1. Remove grinder from hydraulic excavator and place on a level work area with sufficient bearing strength.
2. Secure grinder against falling using suitable lifting equipment and suspend on a crane. During this operation always keep weight in mind.
3. Lifting equipment must be kept tight.
4. Loosen cutter head threaded connections.
5. Screw in lifting bolts. Screwing in lifting bolts causes cutter heads to separate from drive shaft.
6. The cutter head, once loosened from the drive shaft, must be secured against rocking movements by the second person.
7. Carefully lift cutter head away from drive shaft and set down.
8. Remove clamping sleeves in drive shaft using special extractors.

### 6.6.2 Install Cutter Heads

1. Lay grinder with disassembled cutter heads on side using an appropriately weight-rated lifting device.
2. Lift cutter head using suitable weight-rated lifting equipment.
3. Carefully set cutter head on drive shaft.
4. Insert clamping sleeves with opening (slit) opposite turning direction of cutter head.
5. Drive positioned clamping sleeves with mandrel until flush with bearing surface.
6. Insert special washers.
7. Apply thread locking compound to bolt threads. Install bolts.
8. Install disassembly screws without thread locking compound.
9. Torque bolts in a diagonal sequence.  
**Note:** Refer to Torque Tables in the back of this manual.
10. Install bits.

## 6.7 Pedestal (If Equipped)

### 6.7.1 Disassemble Pedestal

1. Loosen screw connection from bolt adapter or quick coupler.
2. Lift bolt adapter or quick coupler off rock and concrete cutting head with suitable lifting equipment.
3. Attach lifting equipment to pedestal and put slight strain on line.

4. Loosen bolts on pedestal.
5. Loosen center bolt on pedestal.
6. Lift up pedestal and set down carefully.

### 6.7.2 Assemble Pedestal

1. Lift bolt adapter or quick coupler with a portal crane and place on cutting head.
2. Ensure hole patterns of intermediate brackets and grinder head align with each other.
3. Attach center bolt and screw on.
4. Insert connection bolts from rock and concrete cutter side and bolt together with pedestal.
5. Install lock nuts on bolts. Torque to specification.

**Note:** Refer to Torque Tables in the back of this manual.

### 6.8 Replace Hydraulic Hoses

#### **NOTICE**

Hydraulic system contamination can damage equipment. Never leave hydraulic ports open. Always plug hydraulic ports and hoses during maintenance when not in use.

1. Clean area around hydraulic hose connections.
2. Loosen threaded connections on hydraulic hose fittings.
3. Loosen hose fitting on hydraulic excavator.
4. Remove hydraulic hose and insert end caps into all fitting openings.
5. Unscrew end cap from one side of new hydraulic hose.
6. Install new hydraulic hose on fitting.
7. Tighten hose.

### 6.9 Remove Dust and Contamination

1. Clean grinder after all maintenance activities.

### 6.10 After Maintenance Inspections

1. Examine threaded connections to ensure they are tight.
2. Check safety devices and covers are installed.
3. Ensure all tools, materials and other equipment are removed from working area.
4. Clean working area and remove spilled substances such as liquids, processing materials and similar items.
5. Ensure all safety devices on machine are fully functional.
6. Ensure hydraulic excavator startup checks are complete.

## 7. Troubleshooting

### **WARNING**

Moving components can cause death or serious injury. Switch machine off and lockout/tag-out to safeguard from being switched on during maintenance. Wait until all parts have stopped before attempting to work on machine. Wear proper clothing and protective equipment.

### **WARNING**

Improper troubleshooting can cause death, serious injury, and damage to property and equipment.

- Make sure there is space for disassembly and assembly before starting work.
- Maintain order and cleanliness at work site. Poorly stacked or scattered parts and tools can cause accidents.

Before restart:

- Make sure all removed parts are correctly reinstalled and fasteners are torqued to specifications.
- Ensure all troubleshooting and work is completed following instructions in this manual.
- Make sure no one is in the hazardous area.
- Ensure all covers and safety devices are installed and functioning.

**Note:** Refer to hydraulic excavator operating instructions when faults occur and during troubleshooting procedures. If actions listed in troubleshooting tables do not eliminate faults, contact Blue Diamond immediately.

FAULT	CAUSE	ACTION
Cutting heads blocked / do not turn	Material trapped between cutting head and gears.	Shut machine down. Relieve hydraulic pressure and lock out controls. Remove trapped material. Run cutter briefly in reverse. Disassemble cutter heads.
	Hydraulic pump pressure too low.	Adjust valve. Increase pressure.
	No oil pressure.	Check hydraulic pump and valves.
	Hydraulic motor damaged.	Flush case drain line. Contact dealer. Exchange hydraulic motor. Replace return line/case drain filter cartridge.
	Damage to gears.	Replace damaged parts. Contact Blue Diamond.
	Check valve installed reversed.	Install check valve correctly.
Cutting heads turn slowly.	Hydraulic pump delivery volume too low.	Increase delivery volume. Replace hydraulic motor with a motor recommended by Blue Diamond with lower displacement volume.
	Poor hydraulic pump efficiency to hydraulic motor.	Replace hydraulic pump or motor.
	Oil leaks between hydraulic pump and hydraulic motor.	Replace damaged hydraulic hoses. Tighten connections.
Cutter stops moving with light pressure.	Excavator operating pressure too low.	Check operating pressure and adjust to recommended value.

FAULT	CAUSE	ACTION
Unusual vibration of cutting heads.	Bits worn, damaged, or uneven lengths.	Replace bits.
	Loose bolts on connection bracket, quick coupler.	Check bushings and bolts for play. Replace if needed.
Bits do not rotate.	Corrosion or debris between bit shaft and block.	Disassemble bits. Clean bit shafts after operation and treat with corrosion inhibitor.
Loud gear noise.	Damage to internal parts.	Contact Blue Diamond. Replace Gears.
Loud hydraulic motor noise.	Air in hydraulic circuit or motor.	Bleed system.
	Low return line pressure.	Check hydraulic installation.
	Internal parts worn from foreign material.	Flush return line. Replace return line filter.
Hydraulic motor overpressure cover deformed, oil leak at seal, pressure limiting valve leak.	Case drain pressure too high. Case drain improperly installed. Case drain filter needs servicing. Case drain shutoff valve closed. Coupling not properly seated.	Check hydraulic installation.

## 8. Storage and Transport

### **NOTICE**

Hydraulic system contamination can damage equipment. Never leave hydraulic ports open. Always plug hydraulic ports and hoses during storage or when not in use.

### 8.1 Transport Inspection

Check delivery immediately upon receipt to ensure it is complete and identify any transport damage. In the event of visible transport damage proceed as follows:

- Reject delivery or accept it only with exceptions.
- Record damage on transport documents or shipper's delivery notes.
- Submit a complaint.

### 8.2 Packaging

Individual packed goods are packaged according to anticipated transport conditions.

**Note:** Packaging protects individual parts against transportation damage, corrosion and other damage until installation. Do not destroy packaging. Remove only before installation.

Dispose of packaging materials in accordance with legal requirements and local regulations.

### 8.3 Transport

#### **WARNING**

Falling or swinging equipment can cause death, serious injury and/or damage to property and equipment.

- Never stand beneath or near swing range of a suspended load.
- Move equipment using safety spotters.
- Use only approved and weight rated lifting equipment.
- Lift only by installed and properly inspected lifting eyes.
- Do not use worn or abraded ropes, slings, chains, or other lifting devices.
- Do not place slings, chains, or other lifting equipment on sharp edges or corners. Never knot or twist lifting devices.
- Never leave suspended load unattended. Set load down in a vertical position.

#### 8.3.1 Crane or Hoist

The grinder is equipped with a lifting lug for lifting by crane under the following conditions:

- Crane and lifting gear must be designed to hoist weight of grinder.
- Operator must be certified to operate crane.



Lifting with crane or hoist instructions:

1. Attach ropes, belts or multi-point suspensions to transport lugs.
2. Ensure grinder hangs straight. If applicable, observe any eccentric center of gravity.
3. Start transport.

### 8.3.2 Forklift

The grinder can be transported using a forklift under the following conditions:

- Forklift must be designed for weight of transport object.
- grinder must be secured to assembly stand with tensioning belts or tensioning braces.

Transporting using a forklift instructions:

1. Drive forklift truck with forks between or beneath bars of assembly stand.
2. Drive in forks until they protrude on opposite side.
3. Ensure assembly stand cannot tip with an eccentric center of gravity.
4. Lift assembly stand with grinder attached and start transport.

### 8.4 Storage

- Always store the grinder on the assembly stand.
- Store dry, free of dust and contamination.
- Avoid mechanical shocks.
- Store protected from mechanical damage.
- Check general condition of all parts and the packaging regularly.

Follow the table below to protect hydraulic motor internal parts during storage:

CLIMATE	LENGTH OF STORAGE			
	3 Months	6 Months	12 Months	24 Months
Temperature	A	B	C	C
Tropical	B	C	D	D
Coastal	C	D	D	D

- A. No special maintenance measures necessary. Install plugs and closures.  
 B. Fill hydraulic motor and hydraulic oil.  
 C. Rinse hydraulic motor with preservation agent.  
 D. Fill hydraulic motor with preservation agent.

### **8.4.1 Cutter Heads**

If cutter heads are stored for an extended period, remove bits and preserve cutter heads with oil.

### **8.4.2 Bits**

If grinder is stored for an extended period of time, remove bits. These can corrode with the cutting material and bond with bit blocks. Preserve bits with oil and store protected against contamination and mechanical damage.

MATERIAL

HEAT TREAT

HIGH PRESSURE LINE / SUPPLY  
(350 BAR / 5075 PSI MAX.,  
Qmax=ACCORDING TO  
OPERATING INSTRUCTIONS)

CASE DRAIN HOSE  
CASE DRAIN PRESSURE (3 BAR / 43.5 PSI MAX.)

LOW PRESSURE LINE / RETURN  
(MIN. 15 BAR / 215.5 PSI)  
50 BAR / 725 PSI MAX.

NON-RETURN (CHECK) VALVE  
5 BAR / 72 PSI

HYDRAULIC MOTOR

INDEPENDENT  
CASE DRAIN  
FILTER

RETURN LINE  
FILTER

OIL TANK

OIL PUMP

VALVE BLOCK

NOTE:

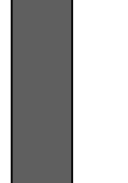
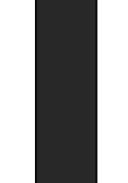
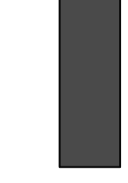
- 1 SUPPLY - 
- 2 RETURN - 
- 3 CASE DRAIN - 

\*LINES SUPPLIED WITH TRANSVERSE CUTTER  
TO FIRST COUPLER ON EXCAVATOR ARM ONLY.

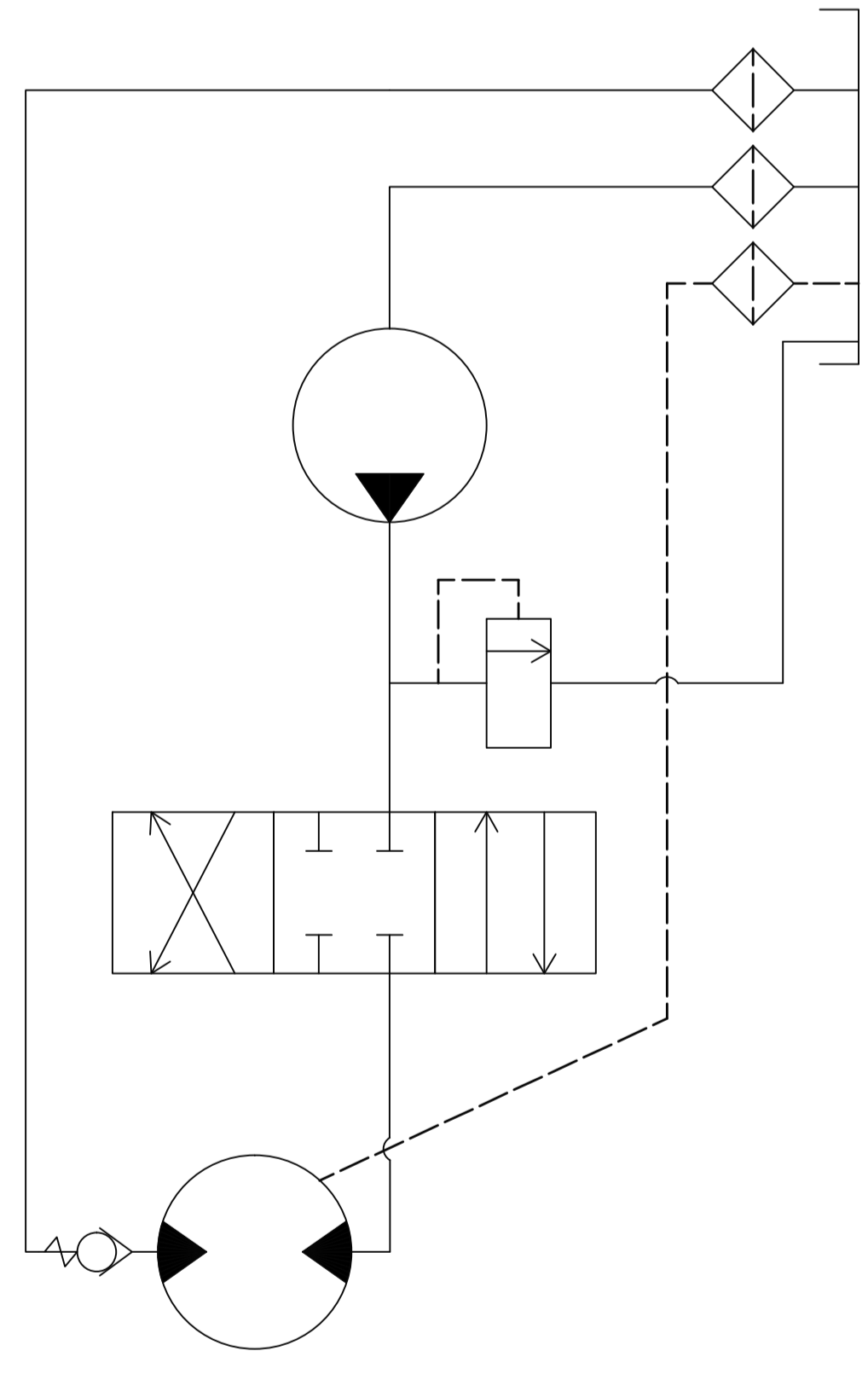
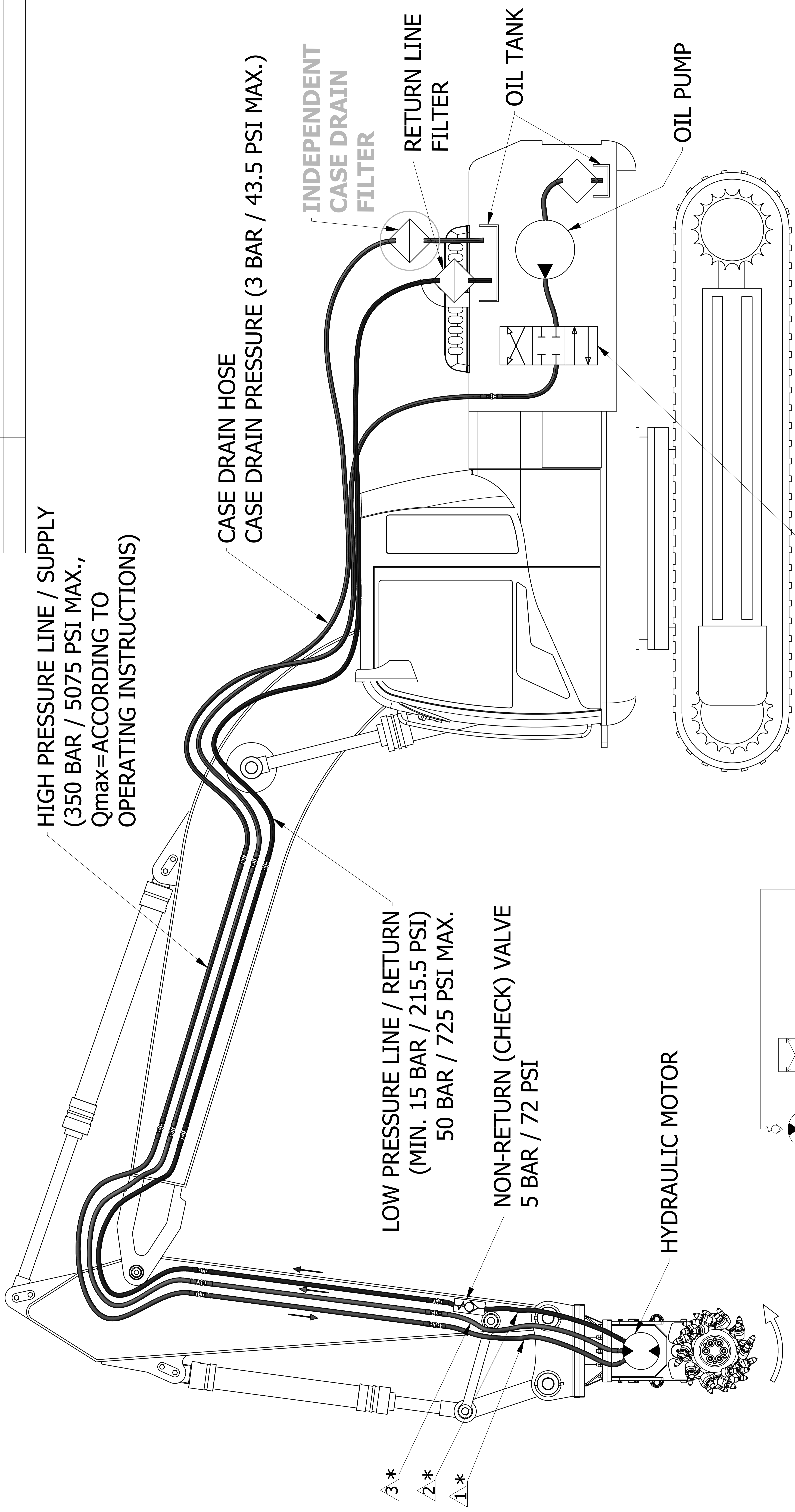

GEOMETRIC DIMENSIONING, TOLERANCING & SURFACE TEXTURE PER  
ASME Y14.5M-1994 UNLESS OTHERWISE SPECIFIED

UNLESS OTHERWISE SPECIFIED  
MILLIMETERS  
X : ± 0.25  
XX : ± 0.13  
XXX : ± 0.075  
FINISH 125 μm  
BREAK ALL SHARP EDGES

DRAWN BY: Chris Spade	CHKD BY:	REF. DWG. NO.
DATE: 7/9/2019	DATE:	
SCALE: 1 : 9	WEIGHT: N/A	3rd ANGLE PROJECTION
PROJECT: HYDRAULIC INSTALLATION 1		
MECHANISM: HYDRAULIC EQUIPMENT		
PART NAME: LP-LINE W/CHECK VALVE DIRECT TO TANK		
DRAWING NUMBER: HYDRAULIC INSTALLATION 1		
REV.   SHEET   SIZE		1   1 of 1   A0

METRIC CAD DRAWING - DO NOT SCALE DRAWING

MATERIAL

HEAT TREAT

HIGH PRESSURE LINE / SUPPLY  
(350 BAR / 5075 PSI MAX.,  
Qmax=ACCORDING TO  
OPERATING INSTRUCTIONS)

CASE DRAIN HOSE  
CASE DRAIN PRESSURE (3 BAR / 43.5 PSI MAX.)

LOW PRESSURE LINE / RETURN  
(MIN. 15 BAR / 215.5 PSI)  
50 BAR / 725 PSI MAX.

INDEPENDENT  
CASE DRAIN FILTER

OIL TANK

OIL PUMP

HYDRAULIC MOTOR

VALVE BLOCK

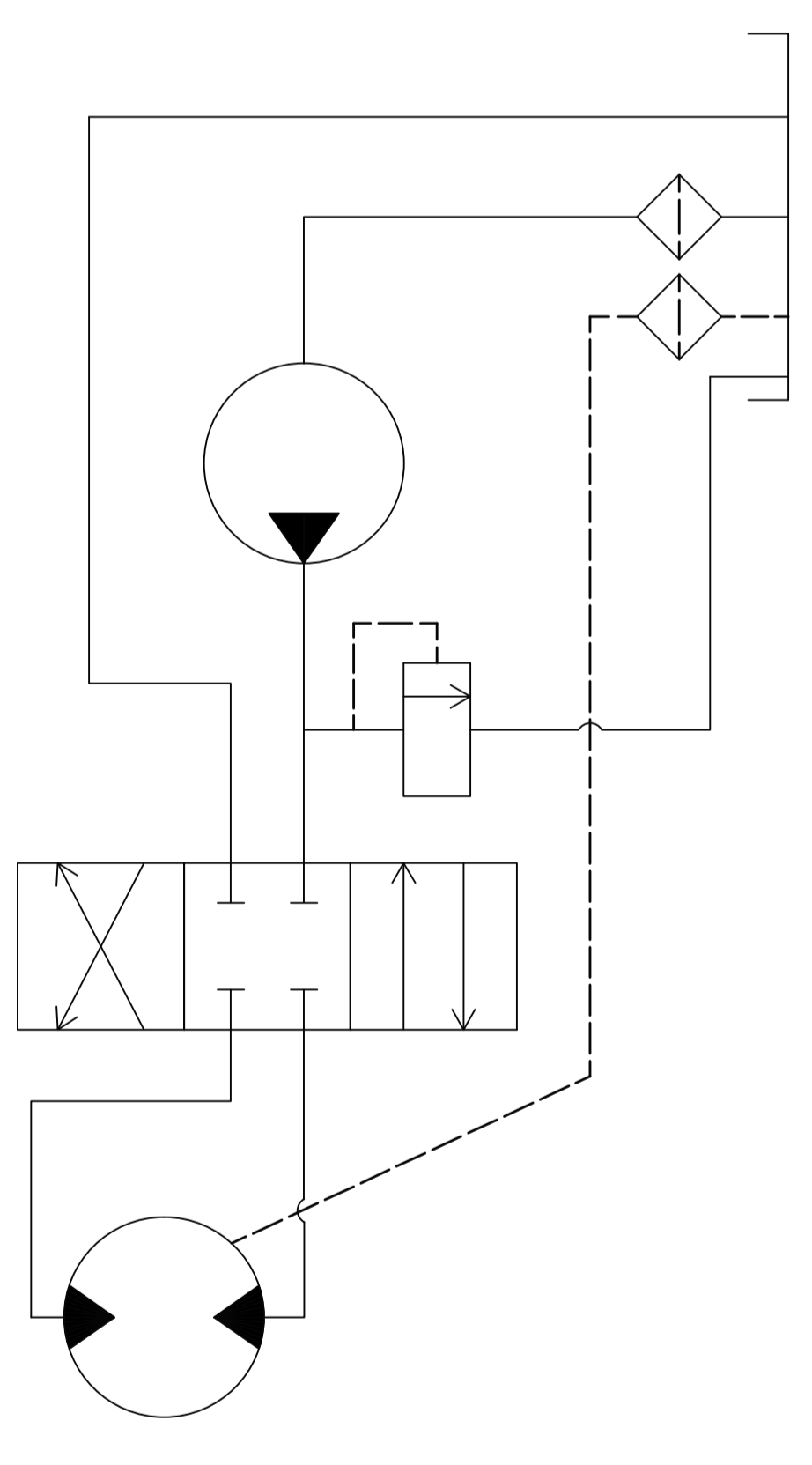
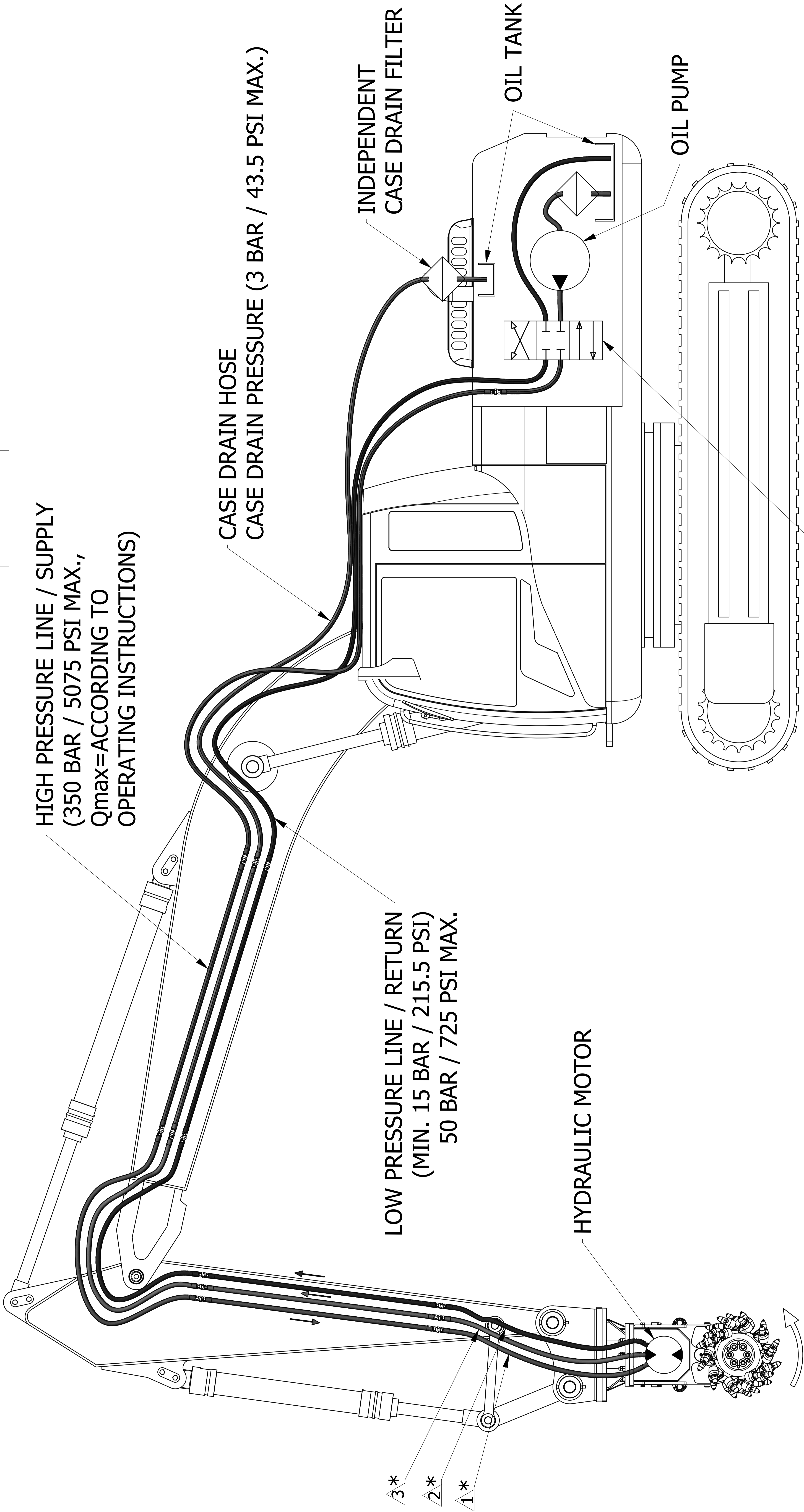

NOTE:

- 1 SUPPLY - [thick line]
- 2 RETURN - [medium line]
- 3 CASE DRAIN - [thin line]

\*LINES SUPPLIED WITH TRANSVERSE CUTTER  
TO FIRST COUPLER ON EXCAVATOR ARM ONLY.

GEOMETRIC DIMENSIONING, TOLERANCING & SURFACE TEXTURE PER  
ASME Y14.5M-1994 UNLESS OTHERWISE SPECIFIED

UNLESS OTHERWISE SPECIFIED  
MILLIMETERS  
INCHES  
X : ± 0.25  
XX : ± 0.13  
XXX : ± 0.05  
FINISH 125µm  
ANGLES : ± 0.5°  
BREAK ALL SHARP EDGES

METRIC CAD DRAWING - DO NOT SCALE DRAWING

DRAWN BY: Chris Spade	CHKD BY:	REF. DWG. NO.
DATE: 7/9/2019	DATE:	
SCALE: 1 : 9	WEIGHT: N/A	3rd ANGLE PROJECTION
PROJECT: HYDRAULIC INSTALLATION 2		
MECHANISM: HYDRAULIC EQUIPMENT		
PART NAME: LP-LINE THROUGH VALVE BLOCK INTO THE TANK	REV. SHEET SIZE	
DRAWING NUMBER: REFERENCE	1 of 1	AO

Values for Zinc Yellow Chromate Fasteners										
CLASS 8.8 METRIC (HEX/SOCKET HEAD) BOLTS CLASS 8 METRIC NUTS						CLASS 10.9 METRIC (HEX HEAD) BOLTS CLASS 10 METRIC NUTS CLASS 12.9 SOCKET HEAD CAP SCREWS M3 - M5*				
Size	PITCH	Tensile Stress Area	Clamp Load	Torque (Dry or Locitite® 263™)	Torque (Lub)	Torque (Locitite® 242™ or 271™ OR Vibra-TITE™ 111 or 140)	Torque (Locitite® 262™ OR Vibra-TITE™ 131)	Torque (Dry or Locitite® 263™) K = 0.20	Torque (Lub OR Locitite® 242™ or 271™ OR Vibra-TITE™ 111 or 140) K=0.18	Torque (Locitite® 262™ OR Vibra-TITE™ 131) K=0.15
		Sq mm	KN	[N.m]	[N.m]	[N.m]	[N.m]	[N.m]	[N.m]	[N.m]
3	0.5	5.03	2.19	1.3	1.0	1.2	1.4	3.13		
3.5	0.6	6.78	2.95	2.1	1.6	1.9	2.3	4.22		
4	0.7	8.78	3.82	3.1	2.3	2.8	3.4	5.47		
5	0.8	14.20	6.18	6.2	4.6	5.6	6.8	8.85		
6	1	20.10	8.74	11	7.9	9.4	12	12.5		
7	1	28.90	12.6	18	13	16	19	18.0	25	19
8	1.25	36.60	15.9	26	19	23	28	22.8	37	27
10	1.5	58.00	25.2	50	38	45	55	36.1	70	55
12	1.75	84.30	36.7	88	66	79	97	52.5	125	95
14	2	115	50.0	140	105	126	154	71.6	200	150
16	2	157	68.3	219	164	197	241	97.8	315	235
18	2.5	192	83.5	301	226	271	331	119.5	430	325
20	2.5	245	106.5	426	320	383	469	152.5	610	460
22	2.5	303	132.0	581	436	523	639	189.0	830	625
24	3	353	153.5	737	553	663	811	222.0	1065	800
27	3	459	199.5	1080	810	970	1130	286.0	1545	1160
30	3.5	561	244.0	1460	1100	1320	1530	349.5	2095	1575
33	3.5	694	302.0	1990	1490	1790	2090	432.5	2855	2140
36	4	817	355.5	2560	1920	2300	2690	509.0	3665	2750
42	4.5	1120	487.0	4090	3070	3680	4290	698.0	5865	4395

NOTES: 1. THESE TORQUE VALUES DO NOT APPLY TO CADMIUM PLATED FASTENERS

2. ALL TORQUE VALUES ARE STATIC TORQUE MEASURED PER STANDARD AUDIT METHODS TOLERANCE = ±10%

## Values for Magni Coated Fasteners

		CLASS 8.8 METRIC (HEX/SOCKET HEAD) BOLTS CLASS 8 METRIC NUTS				CLASS 10.9 METRIC (HEX HEAD) BOLTS CLASS 10 METRIC NUTS CLASS 12.9 SOCKET HEAD CAP SCREWS M6 AND ABOVE*				
Size	PITCH	Tensile Stress Area	Clamp Load	Torque (Dry or Loctite® 263™) K=0.17	Torque (Loctite® 262™ OR Vibra-TITE™ 131) K=0.16	Torque (Loctite® 242™ or 271™ OR Vibra-TITE™ 111 or 140) K=0.15	Clamp Load	Torque (Dry or Loctite® 263™) K = 0.17	Torque (Lub OR Loctite® 242™ or 271™ OR Vibra-TITE™ 111 or 140) K= 0.16	Torque (Loctite® 262™ OR Vibra-TITE™ 131) K=0.15
		Sq mm	KN	[N.m]	[N.m]	[N.m]	KN	[N.m]	[N.m]	[N.m]
3	0.5	5.03	2.19	1.1	1.1	1.0	3.13			
3.5	0.6	6.78	2.95	1.8	1.7	1.5	4.22			
4	0.7	8.78	3.82	2.6	2.4	2.3	5.47			
5	0.8	14.20	6.18	5.3	4.9	4.6	8.85			
6	1	20.10	8.74	9	8.4	7.9	12.5	13	12	11
7	1	28.90	12.6	15	14	13	18.0	21	20	19
8	1.25	36.60	15.9	22	20	19	22.8	31	29	27
10	1.5	58.00	25.2	43	40	38	36.1	61	58	55
12	1.75	84.30	36.7	75	70	66	52.5	105	100	95
14	2	115	50.0	119	110	105	71.6	170	160	150
16	2	157	68.3	186	175	165	97.8	265	250	235
18	2.5	192	83.5	256	240	225	119.5	365	345	325
20	2.5	245	106.5	362	340	320	152.5	520	490	460
22	2.5	303	132.0	494	465	435	189.0	705	665	625
24	3	353	153.5	627	590	555	222.0	905	850	800
27	3	459	199.5	916	860	810	286.0	1315	1235	1160
30	3.5	561	244.0	1245	1170	1100	349.5	1780	1680	1575
33	3.5	694	302.0	1694	1595	1495	432.5	2425	2285	2140
36	4	817	355.5	2176	2050	1920	509.0	3115	2930	2750
42	4.5	1120	487.0	3477	3275	3070	698.0	4985	4690	4395

NOTES: 1. THESE TORQUE VALUES DO NOT APPLY TO CADMIUM PLATED FASTENERS  
 2. ALL TORQUE VALUES ARE STATIC TORQUE MEASURED PER STANDARD AUDIT METHODS TOLERANCE = ±10%

# ROCK GRINDER FULL ASSEMBLY

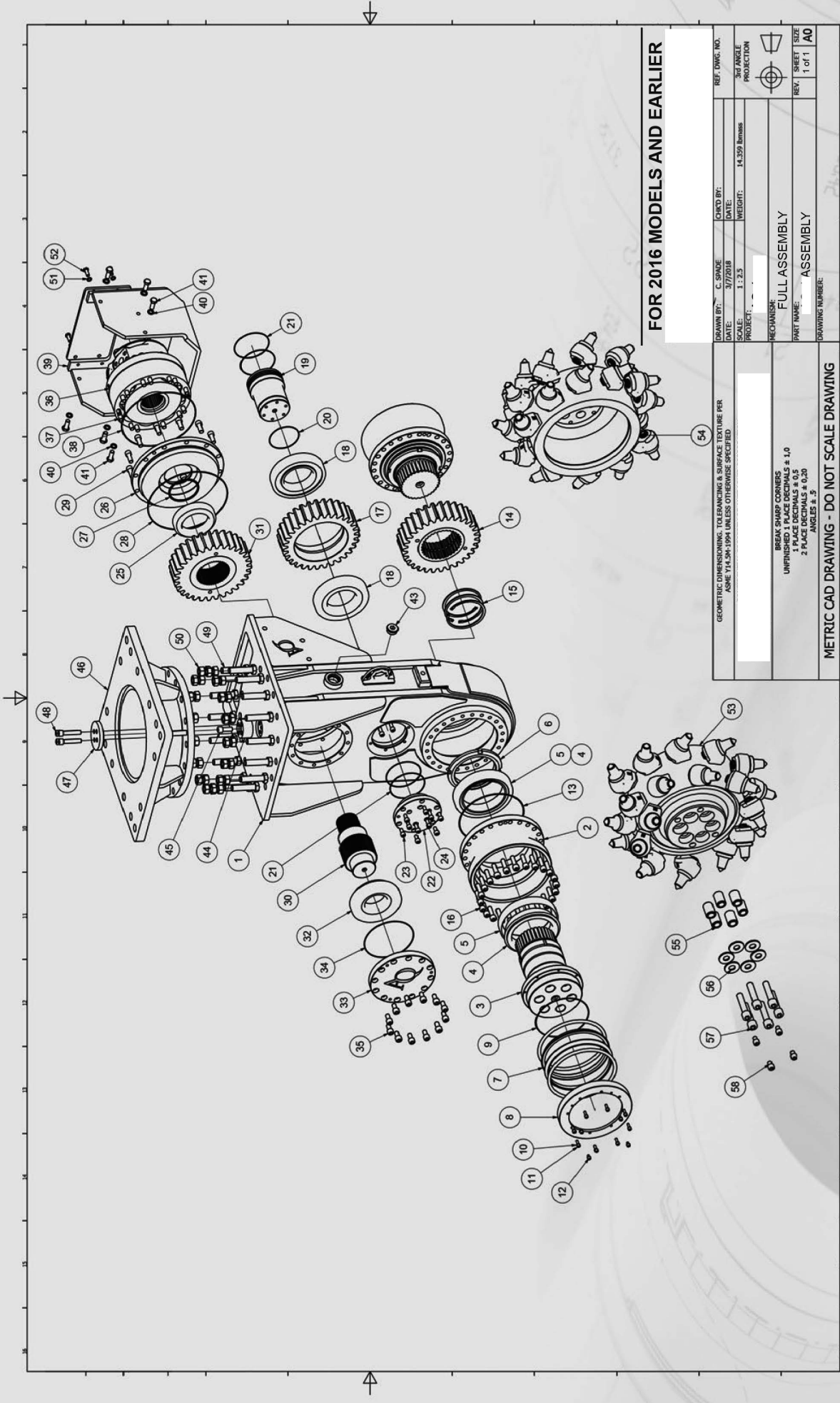

**FOR 2016 MODELS AND EARLIER**

REF. DWG. NO.	
3rd ANGLE PROJECTION	
DRWN BY: C. SPADIE	CHKD BY:
DATE: 3/7/2018	DATE:
PROJECT: 14-239 Demoss	WEIGHT: 14.239 Demoss
MECHANISM: FULL ASSEMBLY	
PART NAME: ASSEMBLY	
REV: 1 of 1	SHEET SIZE: A0
DRAWING NUMBER:	

GEOMETRIC DIMENSIONING, TOLERANCING & SURFACE TEXTURE PER ASME Y14.5M-1994 UNLESS OTHERWISE SPECIFIED

BREAK SHARP CORNERS  
 UNFINISHED SURFACES ± 1.0  
 1 PLACE DECIMALS ± 0.1  
 2 PLACE DECIMALS ± 0.20  
 ANGLES ± .5

METRIC CAD DRAWING - DO NOT SCALE DRAWING

ROCK GRINDER FULL ASSEMBLY

ITEM	PART NUMBER	DESCRIPTION	QTY
1	259400	SWIVEL TRANSMISSION CASE	1
2	259401	ROCK GRINDER MODEL G4 OUTPUT SHAFT HOUSING	2
3	259402	ROCK GRINDER MODEL G4 OUTPUT SHAFT	2
4	259403	ROCK GRINDER MODEL G4 BEARING, INNER RACE	4
5	259404	ROCK GRINDER MODEL G4 BEARING, OUTER RACE	4
6	259405	ROCK GRINDER MODEL G4 LOCKNUT MACHINED	2
7	259406	ROCK GRINDER MODEL G4 SLIDING RING SEAL	2
8	259407	ROCK GRINDER MODEL G4 SEALING LID	2
9	259408	ROCK GRINDER MODEL G4 O-RING	2
10	259409	ROCK GRINDER MODEL G4 USIT RING	24
11	259410	ROCK GRINDER MODEL G4 SOCKET HEAD CAP SCREW	16
12	259411	ROCK GRINDER MODEL G4 SOCKET HEAD CAP SCREW	8
13	259412	ROCK GRINDER MODEL G4 O-RING	2
14	259413	ROCK GRINDER MODEL G4 OUTPUT GEAR	1
15	259414	ROCK GRINDER MODEL G4 RETAINING RING	3
16	259415	ROCK GRINDER MODEL G4 SOCKET HEAD CAP SCREW	48
17	259416	ROCK GRINDER MODEL G4 GEAR #2	1
18	259417	ROCK GRINDER MODEL G4 ROLLER BEARING	2



ROCK GRINDER FULL ASSEMBLY

ITEM	PART NUMBER	DESCRIPTION	QTY
19	259418	ROCK GRINDER MODEL G4 AXLE	1
20	259419	ROCK GRINDER MODEL G4 O-RING	1
21	259420	ROCK GRINDER MODEL G4 O-RING	4
22	259421	ROCK GRINDER MODEL G4 COVER	1
23	259422	ROCK GRINDER MODEL G4 SOCKET HEAD CAP SCREW	6
24	259423	ROCK GRINDER MODEL G4 SOCKET HEAD CAP SCREW	6
25	259424	ROCK GRINDER MODEL G4 ROLLER BEARING	1
26	259425	ROCK GRINDER MODEL G4 MOTOR FLANGE	1
27	259426	ROCK GRINDER MODEL G4 TURCON ROTO GLYD	1
28	259427	ROCK GRINDER MODEL G4 O-RING	1
29	259428	ROCK GRINDER MODEL G4 SOCKET HEAD CAP SCREW	12
30	259429	ROCK GRINDER MODEL G4 DRIVE SHAFT	1
31	259430	ROCK GRINDER MODEL G4 GEAR #1	1
32	259431	ROCK GRINDER MODEL G4 TAPERED ROLLER BEARING	1
33	259432	ROCK GRINDER MODEL G4 COVER PLATE	1
34	259433	ROCK GRINDER MODEL G4 O-RING	1
35	259428	ROCK GRINDER MODEL G4 SOCKET HEAD CAP SCREW	12
36	259435	ROCK GRINDER MODEL G4 HYDRAULIC MOTOR	1

ROCK GRINDER FULL ASSEMBLY

ITEM	PART NUMBER	DESCRIPTION	QTY
37	259436	ROCK GRINDER MODEL G4 SOCKET HEAD CAP SCREW	14
38	259437	ROCK GRINDER MODEL G4 O-RING	1
39	259438	ROCK GRINDER MODEL G4 HYDRAULIC MOTOR COVER	1
40	259439	ROCK GRINDER MODEL G4 SHAKEPROOF WASHER	6
41	259440	ROCK GRINDER MODEL G4 HEX HEAD CAP SCREW	6
43	259441	ROCK GRINDER MODEL G4 HEX PLUG	2
44	259442	ROCK GRINDER MODEL G4 CENTERING BOLT	1
45	259443	ROCK GRINDER MODEL G4 SOCKET HEAD CAP SCREW	1
46	259444	ROCK GRINDER MODEL G4 ADAPTER PLATE	1
47	259445	ROCK GRINDER MODEL G4 FASTENING PLATE	1
48	259446	ROCK GRINDER MODEL G4 SOCKET HEAD CAP SCREW	4
49	259447	ROCK GRINDER MODEL G4 HEX HEAD CAP SCREW	16
50	259448	ROCK GRINDER MODEL G4 HEX NUT	32
51	259449	ROCK GRINDER MODEL G4 SHAKEPROOF WASHER	5
52	259450	ROCK GRINDER MODEL G4 HEX HEAD CAP SCREW	5
53	259451	ROCK GRINDER MODEL G4 CUTTERHEAD RIGHT	1
54	259452	ROCK GRINDER MODEL G4 CUTTERHEAD LEFT	1
55	259453	ROCK GRINDER MODEL G4 CLAMPING SLEEVE	12
56	259454	ROCK GRINDER MODEL G4 WASHER	12
57	259455	ROCK GRINDER MODEL G4 SOCKET HEAD CAP SCREW	12
58	259456	ROCK GRINDER MODEL G4 SOCKET HEAD CAP SCREW	8

ROCK GRINDER BASE PLATE

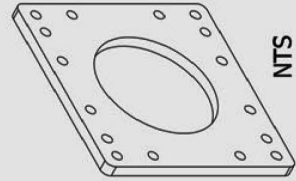

NTS

TOP/BOTTOM OF CUTTER

R25 TYP.

16X Ø32 THRU

SIDES OF CUTTER

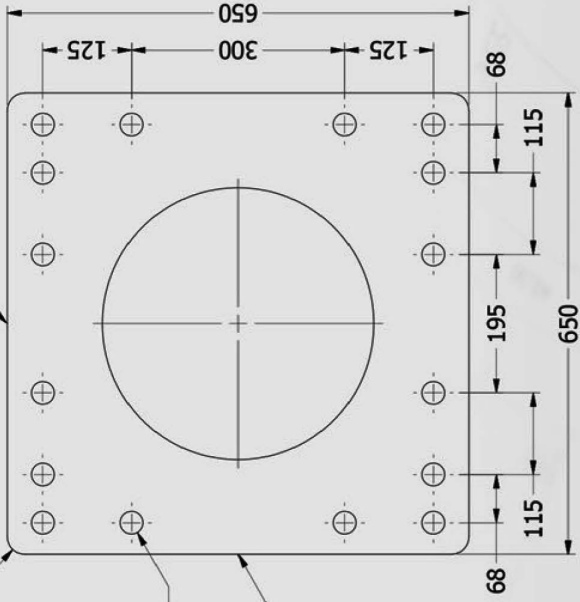

GEOMETRIC DIMENSIONS: TOLERANCES & SURFACE TEXTURE PER ASME Y14.5M-1994 UNLESS OTHERWISE SPECIFIED		DRAWN BY: C. GANDY DATE: 3/7/2018	CHECK'D BY: DATE:	REF. DWG. NO.
SCALE: 1:2.5		PROJECT:	WEIGHT: 14.359 Kilograms	3rd ANGLE PROJECTION
BREAK SHARP CORNERS UNFINISH SURFACES 1 PLACE DECIMALS ± 1.0 2 PLACE DECIMALS ± 0.20 ANGLES ± .5		MECHANISM: HYDRAULIC CUTTER		
METRIC CAD DRAWING - DO NOT SCALE DRAWING		PART NAME: BASE PLATE		
DRAWING NUMBER:		REV. SHEET SIZE 1 of 1 A0		

# ROCK GRINDER

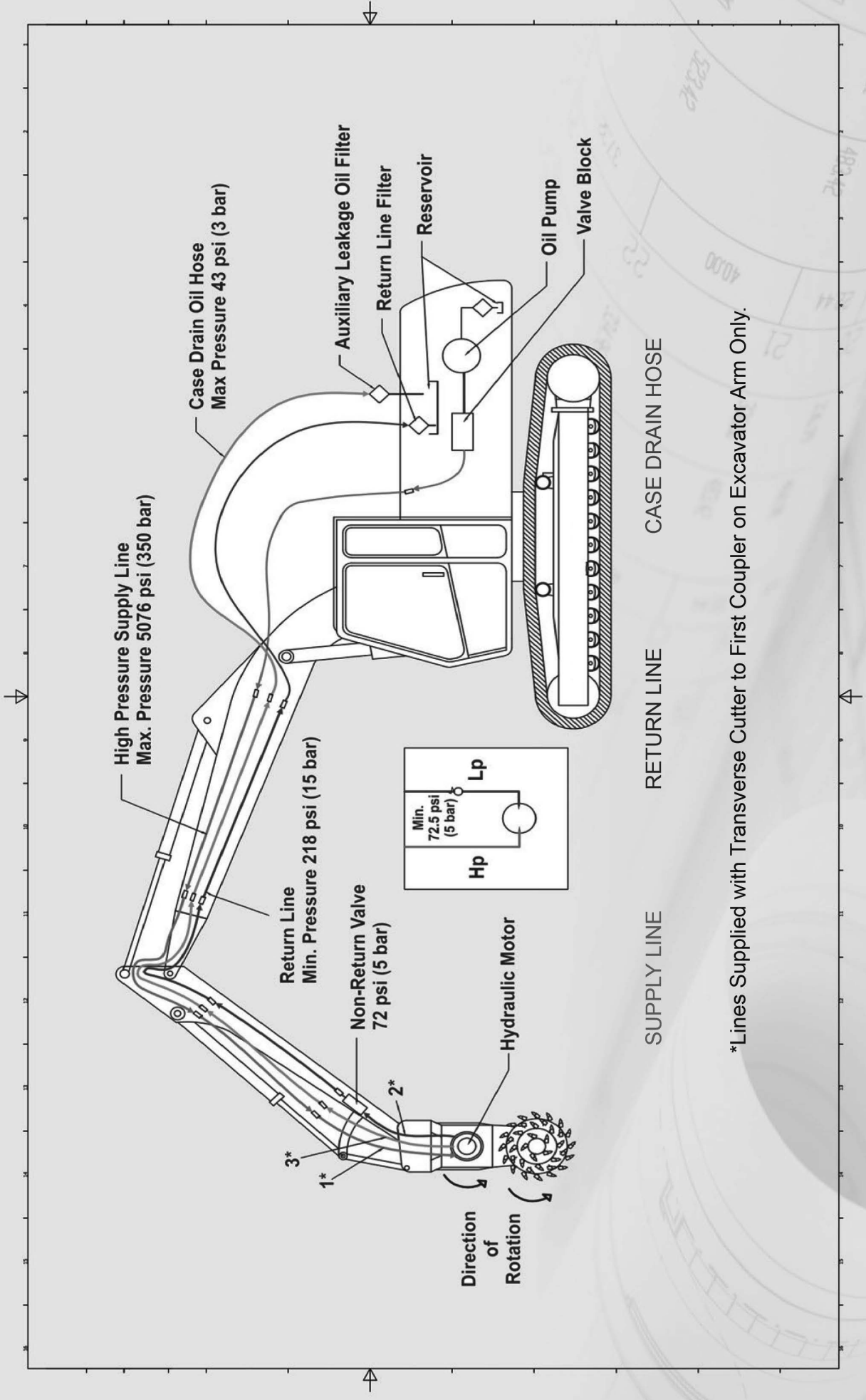

# ROCK GRINDER MOTOR ASSEMBLY

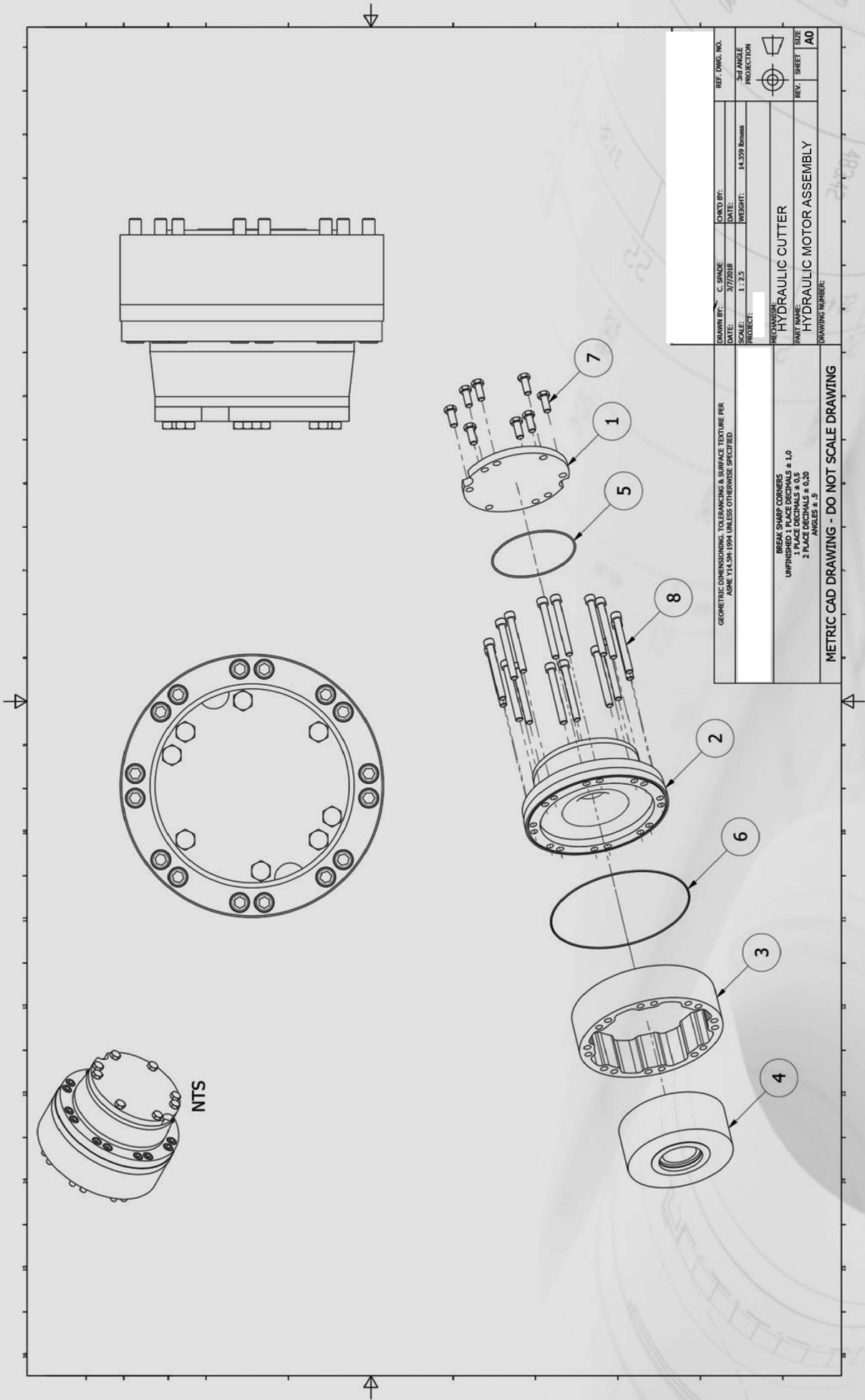

REF. DWG. NO.		
3RD ANGLE PROJECTION		
REVISIONS		
PART NAME:	HYDRAULIC CUTTER	
DRAWING NUMBER:	HYDRAULIC MOTOR ASSEMBLY	
REV.	SHEET	SIZE
	A0	

DRAWN BY:	C. SPADE	CHKD BY:	
DATE:	3/7/2018	DATE:	
SCALE:	1 : 2.5	WEIGHT:	14.359 Kilograms
GEO-METRIC DIMENSIONING, TOLERANCING & SURFACE TEXTURE PER ASME Y14.5M-1994 UNLESS OTHERWISE SPECIFIED			
BREAK SHARP CORNERS UNFINISHED 1 PLACE DECIMALS ± 1.0 1 PLACE DECIMALS ± 0.5 2 PLACE DECIMALS ± 0.20 ANGLES ± 3°			
METRIC CAD DRAWING - DO NOT SCALE DRAWING			

ROCK GRINDER MOTOR ASSEMBLY

ITEM	PART NUMBER	DESCRIPTION	QTY
1	259457	ROCK GRINDER MODEL G4 HYDRAUIC MOTOR COVER	1
2	259458	ROCK GRINDER MODEL G4 DISTRIBUTOR BLOCK	1
3	259460	ROCK GRINDER MODEL G4 CAMRING	1
4	259461	ROCK GRINDER MODEL G4 PISTON BLOCK	1
5	259462	ROCK GRINDER MODEL G4 O-RING	1
6	259437	ROCK GRINDER MODEL G4 O-RING	1
7	259464	ROCK GRINDER MODEL G4 HEX HEAD BOLT	8
8	259465	ROCK GRINDER MODEL G4 CYL. BOLT	16



## **MANUFACTURER'S LIMITED WARRANTY**

BLUE DIAMOND ATTACHMENTS, a manufacturer of quality attachments, warrants new BLUE DIAMOND ATTACHMENTS products and/or attachments at the time of delivery to the original purchaser, to be free from defects in material and workmanship when properly set up and operated in accordance with the recommendations set forth by BLUE DIAMOND ATTACHMENTS, LLC.

BLUE DIAMOND ATTACHMENTS liability for any defect with respect to accepted goods shall be limited to repairing the goods at a BLUE DIAMOND ATTACHMENTS designated location or at an authorized dealer location, or replacing them, as BLUE DIAMOND ATTACHMENTS shall elect. The above shall be in accordance with BLUE DIAMOND ATTACHMENTS warranty adjustment policies. BLUE DIAMOND ATTACHMENTS obligation shall terminate twelve (12) months for the Rock and Concrete Grinder after the delivery of the goods to original purchaser.

This warranty shall not apply to any machine or attachment which shall have been repaired or altered outside the BLUE DIAMOND ATTACHMENTS factory or authorized BLUE DIAMOND ATTACHMENTS dealership or in any way so as in BLUE DIAMOND ATTACHMENTS judgment, to affect its stability or reliability, nor which has been subject to misuse, negligence or accident beyond the Company recommended machine rated capacity.

## **WARRANTY CLAIM**

To submit a warranty claim, a return authorization from BLUE DIAMOND ATTACHMENTS must be obtained. The failed part may then be returned. Tampering with the failed part may void the warranty. This warranty does not include freight or delivery charges incurred when returning machinery for servicing. Dealer mileage, service calls, and pickup/delivery charges are the customers' responsibility.

## **EXCLUSIONS OF WARRANTY**

Except as otherwise expressly stated herein, BLUE DIAMOND ATTACHMENTS makes no representation or warranty of any kind, expressed or implied, AND MAKES NO WARRANTY OF MERCHANTABILITY IN RESPECT TO ITS MACHINERY AND/OR ATTACHMENTS ARE FIT FOR ANY PARTICULAR PURPOSE. BLUE DIAMOND ATTACHMENTS shall not be liable for incidental or consequential damages for any breach or warranty, including but not limited to inconvenience, rental of replacement equipment, loss of profits or other commercial loss. Upon purchase, the buyer assumes all liability for all personal injury and property resulting from the handling, possession, or use of the goods by the buyer.

No agent, employee, or representative of BLUE DIAMOND ATTACHMENTS has any authority to bind BLUE DIAMOND ATTACHMENTS to any affirmation, representation, or warranty concerning its machinery and/or attachments except as specifically set forth herein.

This warranty policy supersedes any previous documents.

**NOTE:** Blue Diamond Attachments is a trademark of BLUE DIAMOND ATTACHMENTS, LLC.



**QUALITY | DEPENDABILITY | INTEGRITY**

Blue Diamond® Attachments  
4512 Anderson Road, Knoxville, TN 37918  
88-376-7027