

Severe Duty Nursery Fork

Operation and Maintenance Manual



Register your
WARRANTY
within 30 days
of purchase



888-376-7027 | BlueDiamondAttachments.com



BD-092

Introduction: Owner Information

Thank you for your decision to purchase a Blue Diamond Nursery Fork. To ensure maximum performance of your equipment, it is mandatory that you thoroughly study the Operator's manual and follow the recommendations. Proper operation and maintenance are essential to maximize equipment life and prevent personal injury.

Operate and maintain this equipment in a safe manner and in accordance with all applicable local, state, and federal codes, regulations and /or laws. Follow all on-product labeling and instructions.

Make sure that all personnel have read this Operator's Manual and thoroughly understand safe and correct operating, installation and maintenance procedures.

Blue Diamond is continually working to improve its products. Blue Diamond reserves the right to make any improvements or changes as deemed practical and possible without incurring any responsibility or obligation to make any changes or additions to equipment sold previously.

Although great care has been taken to ensure the accuracy of this publication, Blue Diamond makes no warranty or guarantee of any kind, written or expressed, implied or otherwise with regard to the information contained within this manual. Blue Diamond assumes no responsibility for any errors that may appear in this manual and shall not be liable under any circumstances for incidental, consequential or punitive damages in connection with, or arising from the use of this manual.

Keep this manual available for frequent reference. All new operators or owners must review the manual before using the equipment and annually thereafter. Contact your Blue Diamond Attachments Dealer for assistance, information, or additional copies of the manual. Contact www.bluediamondattachments.com or call 888-376-7027 for a complete list of dealers in your area.

Serial Number Location:

Please record attachment information in the space provided for future reference.

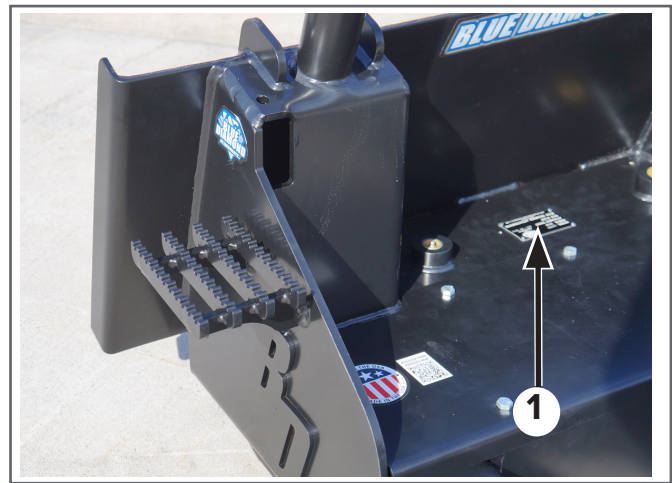

Model Number: _____

Serial Number: _____

Dealer Name: _____

Dealer Number: _____

Date of Purchase: _____

The serial number plate (Item 1) is located on top of the frame.

Always use your serial number when requesting information or when ordering parts.

NOTE: The directions left, right, front, and rear, as mentioned throughout this manual, are as viewed from the operator's position.

Table of Contents

Introduction: Owner Information	2
1. Introduction.....	4
1.1 Attachment Identification	4
2. Safety	5
2.1 General Safety Information	5
3. Operation	8
3.1 General Information.....	8
3.2 Attachment Inspection.....	9
3.3 Attachment Installation.....	10
3.4 Operating the Attachment	12
4. Maintenance	13
4.1 Maintenance Safety	13
4.2 Service Schedule	14
4.3 Storing The Attachment.....	15
5. Parts.....	16
5.1 Nursery Fork Parts	16
6. Specifications	18
6.1 Nursery Fork Specifications.....	18
6.2 Torque Specifications	20
Warranty	21

1. Introduction

1.1 Attachment Identification

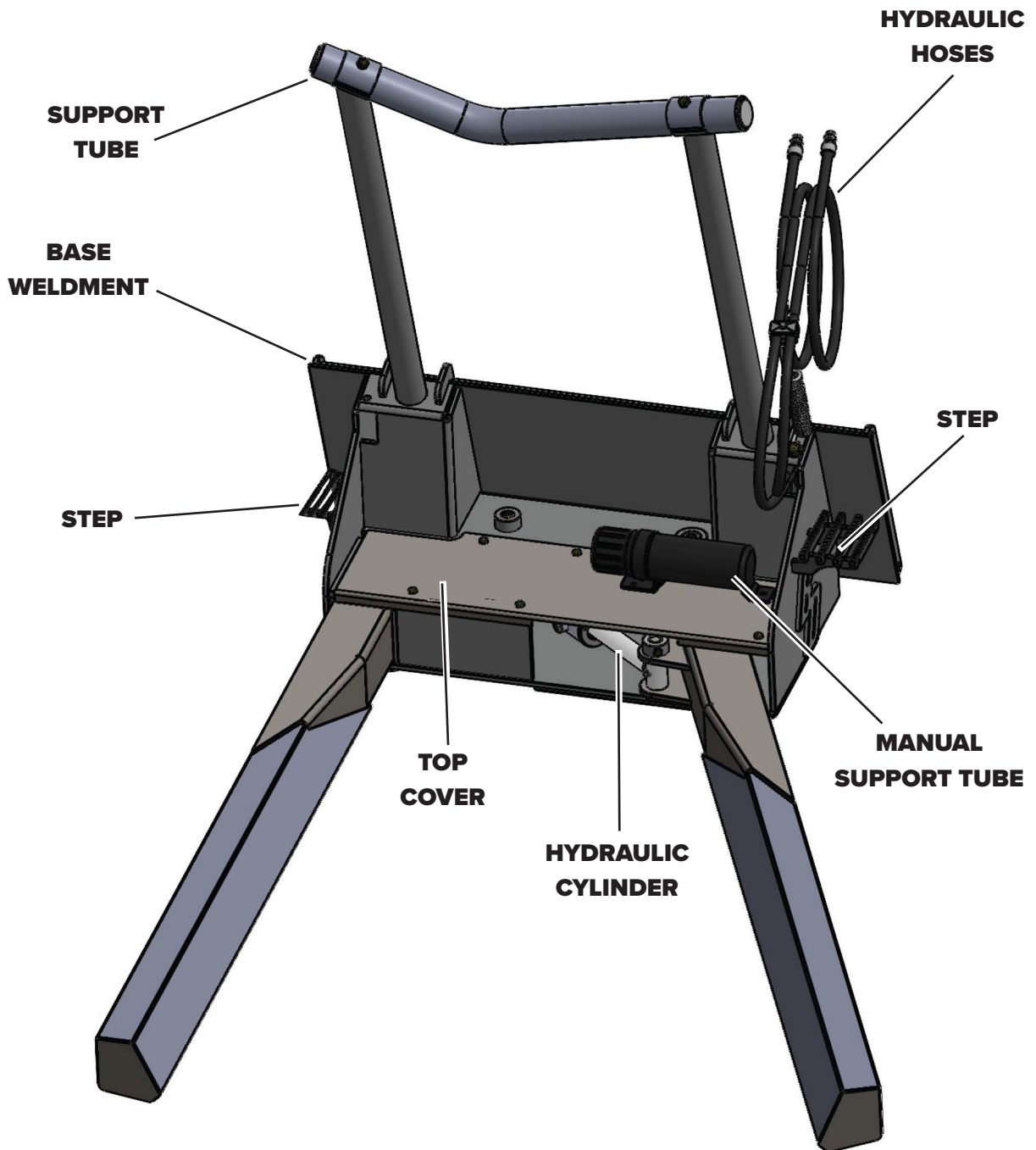

2. Safety

2.1 General Safety Information



This **SAFETY ALERT SYMBOL** identifies important safety messages on the equipment and in the owner's manual. When you see this symbol, be alert to the possibility of personal injury and carefully read the message that follows.



The signal word **DANGER** on the machine and in the manuals indicates a hazardous situation which, if not avoided, will result in death or serious injury.



The signal word **WARNING** on the machine and in the manuals indicates a potentially hazardous situation which, if not avoided, could result in death or serious injury.



The signal word **CAUTION** on the machine and in the manuals indicates a potentially hazardous situation which, if not avoided, may result in minor or moderate injury. It may also be used to alert against unsafe practices.



The signal word **IMPORTANT** identifies procedures which must be followed to avoid damage to the machine.

Safe Operation Needs a Qualified Operator



AVOID SERIOUS INJURY OR DEATH
Operators must receive instructions before operating the machine. Untrained operators can cause serious injury or death. For an operator to be qualified, he or she must not use drugs or alcoholic drinks which impair alertness or coordination while working. An operator who is taking prescription drugs must get medical advice to determine if he or she can safely operate a machine and the equipment.

Operator Training

- Check the rules and regulations at your location. The rules may include an employer's work safety requirements. Regulations may apply to local driving requirements or use of a Slow Moving Vehicle (SMV) emblem. Regulations may identify a hazard such as a utility line.
- The new operator must start in an area without bystanders and use all the controls until he or she can operate the machine safely under all conditions of the work area.

2. Safety

2.1 General Safety Information

Importance of Safety

Operating Safety

- Read and follow instructions in this manual and the machine's Operator's Manual before operating.
- This equipment is dangerous to persons unfamiliar with its operation.
- Check for overhead and / or underground lines before operating equipment (if applicable).
- In addition to the design and configuration of equipment, hazard control and accident prevention are dependent upon the awareness, concern, prudence and proper training of personnel involved in the operation, transport, maintenance and storage of equipment.
- Check that the attachment is securely fastened to the machine.
- Make sure all the machine controls are in NEUTRAL before starting the machine.
- Operate the equipment only from the operator's position.
- Operate the equipment according to the Operator's Manual.
- When learning to operate the equipment, do it at a slow rate in an area clear of bystanders.
- DO NOT permit personnel to be in the work area when operating the equipment.
- The equipment must be used ONLY on approved machines.
- DO NOT modify the equipment in any way. Unauthorized modification may impair the function and / or safety and could affect the life of the equipment. Warranty may also be affected or voided.
- DO NOT make any adjustments or repairs on the equipment while the machine is running.
- Keep shields and guards in place. Replace if damaged.
- DO NOT operate equipment in poor visibility conditions such as fog, darkness, or any conditions that limit clear visibility less than 300 feet (100 m) in front of and to the sides of the equipment.
- DO NOT operate in a work area that has not been inspected for foreign debris and obstacles.
- Remove any foreign objects and clearly mark any objects that cannot be removed.
- Wear safety glasses, gloves, hearing protection and other protective clothing when required.

2. Safety

2.1 General Safety Information

Importance of Safety (Cont'd)

Fire Prevention Safety

- Flammable debris (leaves, grass, etc.) must be removed regularly. If flammable debris is allowed to accumulate, it can cause a fire hazard. Clean often to avoid this accumulation.
- All fuels, most lubricants and some coolant mixtures are flammable. Flammable fluids that are leaking or spilled onto hot surfaces or onto electrical components can cause a fire.

Transporting Safety

- Comply with state and local laws governing highway safety and movement of machinery on public roads.
- Check local laws for all highway lighting and marking requirements.
- Never allow riders on either machine or equipment.
- If transporting the attachment on a truck or trailer, make sure it is properly secured to the transport vehicle.

Hydraulic System

- Check hydraulic tubes, hoses and fittings for damage and leakage. Never use open flame or bare skin to check for leaks. Hydraulic tubes and hoses must be properly routed and have adequate support and secure clamps. Tighten or replace any parts that show leakage.
- Always clean fluid spills. Do not use gasoline or diesel fuel for cleaning parts. Use commercial nonflammable solvents.

3. Operation

3.1 General Information

Pre-Operation Inspection

Before operating the Nursery Fork for the first time and each time thereafter, use the following list as a guideline during equipment inspection.



WARNING



AVOID SERIOUS INJURY OR DEATH

- Disengage machine's auxiliary hydraulics, engage the machine's parking brake, stop the engine and make sure all rotating components are completely stopped before connecting, disconnecting, adjusting or cleaning equipment.
- Always keep shields and all guards in place when using the equipment.
- Disengage machine's auxiliary hydraulics for road travel.
- Keep hands, feet and clothing away from rotating parts.

- Lubricate the attachment per the schedule outlined in the Maintenance Section. See "Service Schedule" on page 14.
- Check the nursery fork mounting frame for damage or cracks.
- Check that all shields and guards are in place.
- Check for loose bolts and tighten them if necessary.
- Check all welds on the attachment for wear and damage each time the attachment is removed from the machine.
- Check for damaged or missing safety decals. Replace if necessary.
-

- Inspect the machine's mounting frame. (See the machine's Operator's Manual for inspecting the mounting frame). Replace any parts that are damaged, bent or missing. Keep all fasteners tight. Look for cracked welds.



WARNING



Leaking fluids under pressure can enter the skin and cause serious injury or death. Immediate medical attention is required. Wear goggles. Use cardboard to check for leaks.

- Check condition of all hydraulic components for leaks. Repair as required.

NOTE: Do not operate with hydraulic leaks.

- Verify that the nursery fork is properly connected to the machine.

3. Operation

3.2 Attachment Inspection

Daily Inspection

NOTE: Inspect the attachment by performing a walk around daily before and after use. Use the following inspection checklist as a guideline.

Check the following items every 10 hours of operation:

- Verify that the nursery fork is properly connected to the machine.
- Check that all shields and guards are in place.
- Check hydraulic lines, connections and fittings for hydraulic oil leaks. Repair or replace damaged parts if necessary.
- Check the nursery fork mounting hardware for wear or damage. Inspect the pins and mount (on the attachment) for wear or damage. Repair or replace damaged parts if necessary.

Weekly Inspection

Check the following items every 40 hours of operation:

- Check all bolts for tightness.
- Check hydraulic tubes, hoses and fittings for wear, damage and leakage.
- Inspect the frame and forks for cracks, bends, or damage.
- Check for damaged or missing decals. Replace if necessary.
- Lubricate as required.
- Check that all bolts are tight.

Drive the machine to the Nursery Fork and align the machine to the frame for connection. Stop the engine, exit the machine, and secure the Nursery Fork mounting frame to the machine.



WARNING



AVOID SERIOUS INJURY OR DEATH

Before servicing the attachment:

- **Always park on a flat level surface.**
- **Lower lift arms and place attachment flat on the ground.**
- **Place all controls in NEUTRAL.**
- **Engage the park brake.**
- **Wait for all moving parts to stop.**
- **Stop the engine and remove the key.**

SEE MACHINE'S OPERATOR'S MANUAL FOR ADDITIONAL INFORMATION.

3. Operation

3.3 Attachment Installation

 **IMPORTANT** 



SEE MACHINE'S OPERATOR'S MANUAL FOR DETAILED INFORMATION ON OPERATING THE LOADER.

Entering the Operator's Position

Use the attachment safety treads, handles and steps (on the machine) to enter the operator's position.

When in the operator's position, lower safety seat bar, fasten the seat belt, start the engine and release the parking brake.

Leaving the Operator's Position

 **WARNING** 

AVOID SERIOUS INJURY OR DEATH

Before servicing the attachment:

- **Always park on a flat level surface.**
- **Lower lift arms and place attachment flat on the ground.**
- **Place all controls in NEUTRAL.**
- **Engage the park brake.**
- **Wait for all moving parts to stop.**
- **Stop the engine and remove the key.**

SEE MACHINE'S OPERATOR'S MANUAL FOR ADDITIONAL INFORMATION.

Park the machine / attachment on a flat level surface. Place all controls in neutral, engage the park brake and stop the engine. Leave the operator's position.

Connecting Attachment to the Machine

 **WARNING** 

CRUSH HAZARD

- **Before moving the machine, look in all directions and make sure no bystanders, especially small children are in the work area. Do not allow anyone between the machine and attachment when approaching the attachment for connecting.**
- **Keep fingers and hands out of pinch points when connecting and disconnecting attachment.**

Before connecting to the attachment, inspect the machine's mounting plate. (See the machine's Operator's Manual for inspecting the mounting frame).

(See the machine's Operator's Manual for inspecting the mounting frame).

Enter the operator's position. See "Entering the Operator's Position" on page 10.

Drive the machine slowly forward, until the top edge of the machine's mounting plate is under the top flange of the attachment mounting frame.

3. Operation

3.3 Attachment Installation

Connecting Attachment to the Machine (Cont'd)

Slowly tilt the machine's mounting plate back until the attachment mounting frame fully contacts the front of the machine's mounting plate.

Leave the operator's position. See "Leaving the Operator's Position" on page 10.



WARNING



AVOID SERIOUS INJURY OR DEATH

The locking pins / wedges must extend through the holes in the attachment mounting frame. Failure to secure locking pins / wedges can allow attachment to come off.

SEE MACHINE'S OPERATOR'S MANUAL FOR ADDITIONAL INFORMATION.

Engage attachment locking levers / wedges (See the machine's Operator's Manual for detailed information).

Connecting Hydraulic Hoses



IMPORTANT



Thoroughly clean the quick couplers before making connections. Dirt can damage the hydraulic system.

Remove dirt or debris from the male and female couplers. Visually inspect the couplers for corroding, cracking, damage, or excessive wear. Connect the attachment hydraulic hoses to the machine. Pull on each hose to verify full connection is made.

Disconnecting Hydraulic Hoses



WARNING



AVOID BURNS

Hydraulic fluid, tubes, fittings and quick couplers can get hot during operation. Be careful when connecting and disconnecting hydraulic hoses.

Relieve auxiliary hydraulic pressure. (See the machine's Operator's Manual for correct procedure.)

Disconnect attachment hydraulic hoses from the machine.

Disconnecting Attachment from the Machine

Relieve auxiliary hydraulic pressure. (See the machine's Operator's Manual for correct procedure.)

Park the machine and attachment on a flat level surface.

Lower the nursery fork flat on the ground.

Leave the operator's position. See "Leaving the Operator's Position" on page 10.

Disconnect attachment hydraulic hoses from the machine. Connect the hydraulic couplers together or install plugs or caps on the couplers.

Disengage locking pins / wedges. (See the machine's Operator's Manual for correct procedure.)

Enter the operator's position. See "Entering the Operator's Position" on page 10.

3. Operation

3.3 Attachment Installation

Disconnecting Attachment from the Machine (Cont'd)

Slowly tilt the machine's mounting plate forward until the attachment mounting frame is free from the machine's mounting plate.

Drive the machine slowly backward, away from the attachment.

3.4 Operating the Attachment Machine Requirements

The nursery fork attachment can be used for transporting up to 44" balled and container grown trees and shrubs along with rocks and boulders.



Drive forward and position the tree between the forks and as close to the fork frame as possible. Gently angle the fork inward until the forks contact the tree ball or container. Use the loader arms to raise or lower the tree.

The pressure must be enough to securely hold the tree without damaging the burlap bag, rootball or container.

For transporting, carry tree as close to the attachment as possible for stability and to maximize the life of the attachment.

NOTE: If the tree appears to be unstable, lower the nursery fork and either increase pressure on the load or open the arms and reposition.

NOTE: Carrying the tree close to the fork frame will also reduce bouncing of the tree ball during transport and will minimize possible damage to the rootball.

NOTE: Do not transport a tree at the end of the arms. Place the tree at the end of the arms for tree placement only.



- Only use nursery fork on compatible loaders.
- Refer to the machine's operator's manual for flow and pressure specifications.

Operating the Nursery Fork

Install the Nursery Fork onto the loader. (See the machine's operator's manual for correct procedure).

Enter the operator's position. See "Entering the Operator's Position" on page 10.

Raise the nursery fork slightly off the ground.

Cycle the nursery fork cylinder several times to purge the hydraulic system of air.

To pick up a tree or shrub, angle the fork to a width larger than the tree ball or container.

4. Maintenance

4.1 Maintenance Safety



WARNING



AVOID SERIOUS INJURY OR DEATH

Never operate the machine in a closed building. Proper ventilation is required when operating the machine under all circumstances.

- Always keep the work area clean and dry.
- Always use personal protection devices such as eye, hand and hearing protection when performing any service or maintenance.
- A fire extinguisher and first aid kit should be readily accessible while performing maintenance on this machine.
- Before working or doing maintenance on this machine, shut off the engine and remove the key. Make sure the machine's wheels are blocked.
- Never work under the machine or attachment unless the machine or equipment is blocked or supported securely.
- Disconnect the battery (both terminals) before welding on any part of the machine. Failure to do so may cause damage to electrical components.
- When working around batteries, remember that all of the exposed metal parts are "live". Never lay a metal object across the terminals because a spark, short circuit, explosion or personal injury may result.
- Battery posts, terminals and related accessories contain lead and lead compounds. **Wash hands after handling.**

- Always relieve hydraulic system pressure before repairing, adjusting or disconnecting. Never search for leaks with your hands.
- When replacement parts are necessary, genuine factory replacement parts must be used to restore your equipment to original specifications. Blue Diamond will not be responsible for injuries or damage caused by use of unapproved parts and / or accessories.

General Maintenance



WARNING



AVOID SERIOUS INJURY OR DEATH

Never operate the machine in a closed building. Proper ventilation is required when operating the machine under all circumstances.

To ensure efficient operation, you should inspect, lubricate, and make necessary adjustments and repairs at regular intervals. Keep good maintenance records and adequately clean your machine after each use.

Proper Maintenance and lubrication is important. Follow instructions in the service schedule.

NOTE: Repair or replace any damaged parts.

4. Maintenance

4.2 Service Schedule

! **IMPORTANT** !

Fluid such as hydraulic fluid, coolants, grease, etc. must be disposed of in an environmentally safe manner. Some regulations require that certain spills and leaks on the ground must be cleaned in a specific manner. See local, state and federal regulations for the correct disposal.

! **WARNING** !

AVOID SERIOUS INJURY OR DEATH
Never work under the machine or attachment unless the machine or equipment is blocked or supported securely.

DESCRIPTION	SERVICE PROCEDURES			
	Check	Clean	Lube	Change
Daily Maintenance (or every 8 hours)				
Hydraulic Fittings	•			
Hydraulic Hoses	•			
All Hardware	•			
Nursery Fork Frame	•	•		
Pivot Pins			•	
Hydraulic Cylinder			•	

NOTE: Check nursery fork for correct function after adjustments, repairs or service.



See image to the left for greasing locations

4. Maintenance

4.3 Storing The Attachment

Storage

Sometimes it may be necessary to store your nursery fork for an extended period of time. Below is a list of items to perform before storage.

- Make sure the hydraulic hose couplers are capped, plugged, or connected to each other.
- Thoroughly wash the nursery fork before storing the nursery fork for long periods.
- Lubricate the nursery fork.
- Coat the exposed portion of the cylinder rod with grease.
- Check for loose hardware, missing guards, or damaged parts.
- Check for damaged or missing decals. Replace if necessary.
- Replace worn or damaged parts.
- Place the attachment in a dry protected shelter.
- Place the attachment flat on the ground.

NOTE: In muddy conditions or to prevent the attachment from freezing to the ground, put the attachment on planks or blocks before removing the attachment from the machine.

Return to Service

After the nursery fork has been in storage, it is necessary to follow a list of items to return the nursery fork to service

- Lubricate the nursery fork.
- Install and operate the nursery fork and check for correct function.
- Check for leaks. Repair as needed.

5. Parts

5.1 Nursery Fork Parts

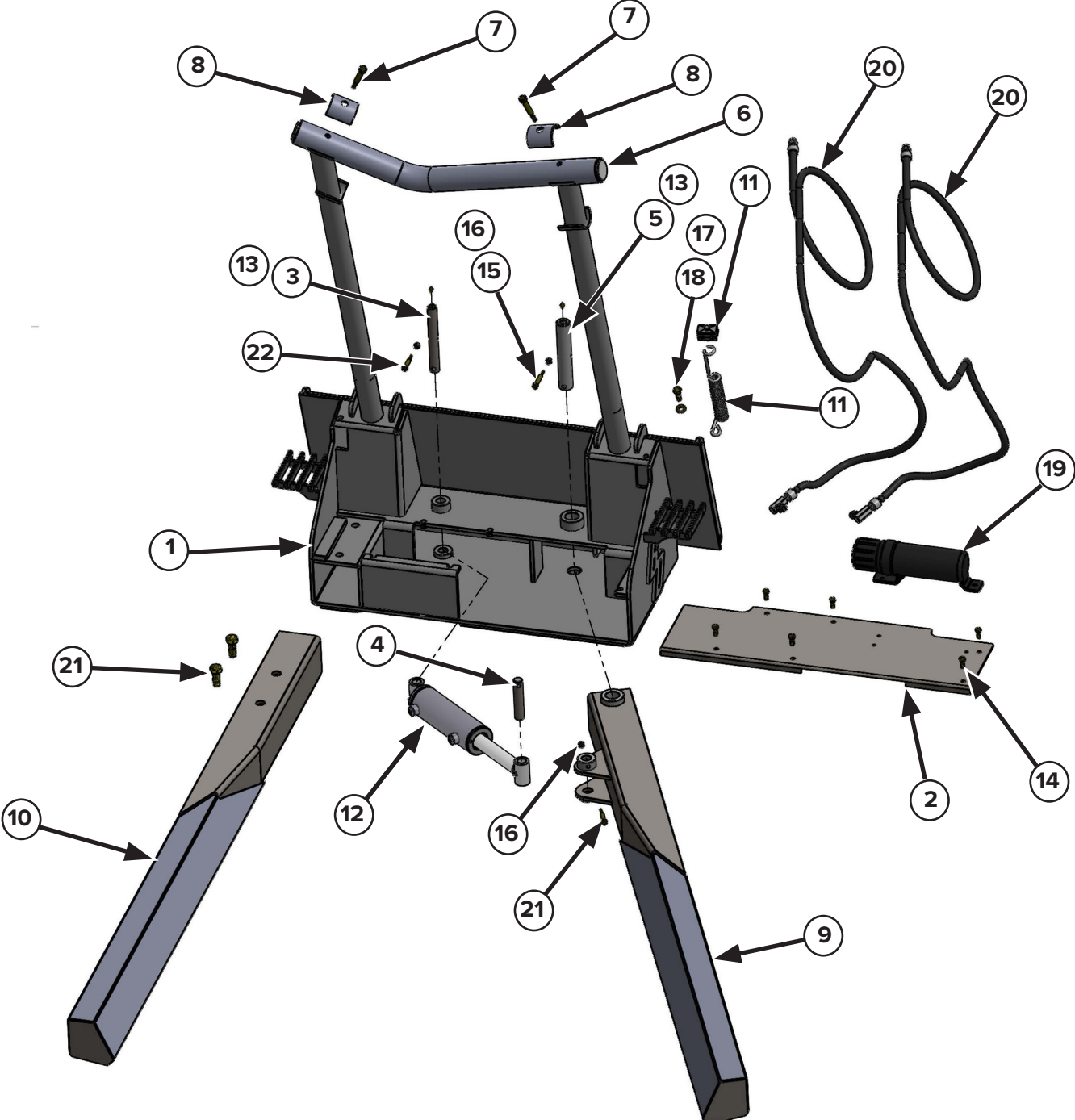

5. Parts

5.1 Nursery Fork Parts

ITEM	PART NUMBER	DESCRIPTION	QTY
1	214095	BASE WELDMENT	1
2	214303	TOP COVER	1
3	214308	CYLINDER TO FRAME PIN	1
4	214309	CYLINDER TO ARM PIN	1
5	214310	ARM MAIN PIVOT PIN	1
6	214304	TRUNK REST TUBE	2
7	299436	HEX BOLT - GRADE 8 - 1/2-13 X 3 1/2 2	2
8	214305	TOP TUBE CLAMP	2
9	214306	LEFT ARM	1
10	214307	RIGHT ARM	1
11	206800	HOSE SAVER KIT	1
12	214300	HYDRAULIC CYLINDER	1
13	299016	1/8 PTF MALE - STRAIGHT GREASE FITTING	2
14	299423	HEX BOLT - GRADE 8 - 3/8-16 X 1	6
15	299425	HEX BOLT - GR 8 - 3/8-16 X 3.00	1
16	299625	LOCKNUT - .375-16	3
17	299732	WASHER - GRADE 8 - FOR Ø1/2"	1
18	299432	HEX HEAD 1/2"-13 x 1-1/2"; GRADE 8	1
19	216402	STORAGE TUBE FOR MANUAL	1
20	214302	HOSE SET	1
21	299454	HEX HEAD SCREW 3/4-10 X 2 GRADE 8	2
22	299329	HEX BOLT - GRADE 8 - 3/8"-16 X 2 1/2"	2
NS	224018	Male Hydraulic Coupler	1
NS	224017	Female Hydraulic Coupler	1

6. Specifications

6.1 Nursery Fork Specifications

Dimensions

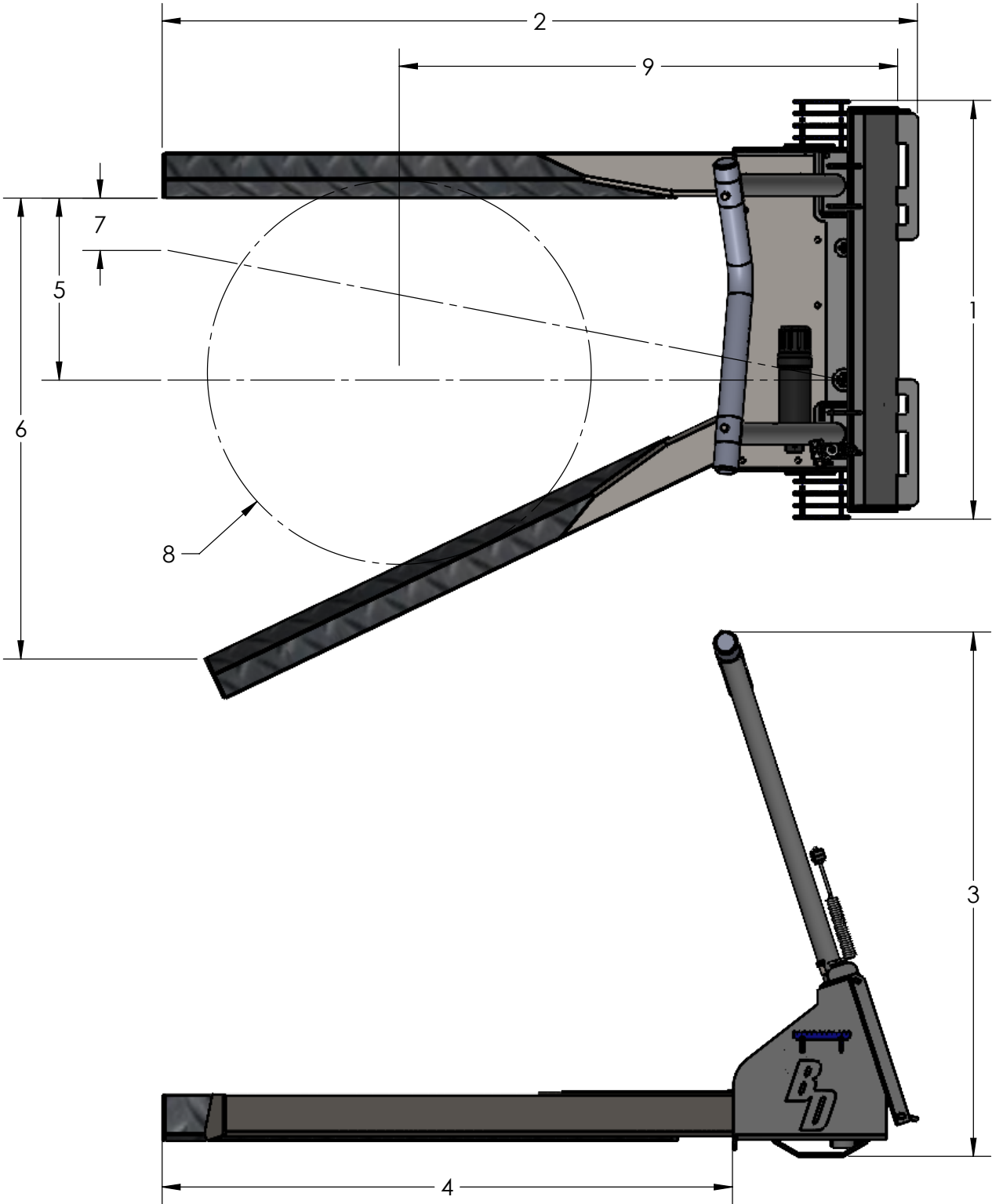

6. Specifications

6.1 Nursery Fork Specifications

ITEM	DESCRIPTION	SD NURSERY FORK
1	OVERALL WIDTH	48 in.
2	OVERALL LENGTH	86-1/2 in.
3	OVERALL HEIGHT	60-1/2 in.
4	FORK LENGTH	65.00 in.
5	FORK OPENING, PARALLEL	17-3/4 in.
6	FORK OPENING, OPEN	54 in.
7	FORK OPENING, CLOSED	6 in.
8	MAXIMUM BALL SIZE	Ø 44 in.
9	DISTANCE FROM SS MOUNT TO C/L OF BALL	57 in.
10	WEIGHT	650 lbs.
11	MAXIMUM LOAD CAPACITY	3000 lbs.

6. Specifications

6.2 Torque Specifications

Standard Hardware, Lock & Nuts

BOLT								
BOLT TYPE	SAE GRADE 5		SAE GRADE 8		LOCK NUTS			
Nominal Size	Plated or Unplated	Plated W/ ZnCr	Plated or Unplated	Plated W/ ZnCr	Plated or Unplated	Plated W/ ZnCr	W/ Grade 5 Bolt	W/ Grade 8 Bolt
	Silver	Gold	Silver	Gold	Silver	Gold		
1/4	55 ft / lb (6.2 N•m)	72 ft / lb (8.1 N•m)	86 in / lb (9.7 N•m)	112 in / lb (12.6 N•m)	121 in / lb (13.6 N•m)	157 in / lb (17.7 N•m)	61 in / lb (6.9 N•m)	86 in / lb (9.8 N•m)
5/16	115 ft / lb (13 N•m)	149 ft / lb (17 N•m)	178 ft / lb (20 N•m)	229 ft / lb (26 N•m)	250 ft / lb (28 N•m)	325 ft / lb (37 N•m)	125 ft / lb (14 N•m)	176 ft / lb (20 N•m)
3/8	17 ft / lb (23 N•m)	22 ft / lb (30 N•m)	26 ft / lb (35 N•m)	34 ft / lb (46 N•m)	37 ft / lb (50 N•m)	48 ft / lb (65 N•m)	19 ft / lb (26 N•m)	26 ft / lb (35 N•m)
7/16	27 ft / lb (37 N•m)	35 ft / lb (47 N•m)	42 ft / lb (57 N•m)	54 ft / lb (73 N•m)	59 ft / lb (80 N•m)	77 ft / lb (104 N•m)	30 ft / lb (41 N•m)	42 ft / lb (57 N•m)
1/2	42 ft / lb (57 N•m)	54 ft / lb (73 N•m)	64 ft / lb (87 N•m)	83 ft / lb (113 N•m)	91 ft / lb (123 N•m)	117 ft / lb (159 N•m)	45 ft / lb (61 N•m)	64 ft / lb (88 N•m)
9/16	60 ft / lb (81 N•m)	77 ft / lb (104 N•m)	92 ft / lb (125 N•m)	120 ft / lb (163 N•m)	130 ft / lb (176 N•m)	169 ft / lb (229 N•m)	65 ft / lb (88 N•m)	92 ft / lb (125 N•m)
5/8	83 ft / lb (112 N•m)	107 ft / lb (145 N•m)	128 ft / lb (174 N•m)	165 ft / lb (224 N•m)	180 ft / lb (244 N•m)	233 ft / lb (316 N•m)	90 ft / lb (122 N•m)	127 ft / lb (172 N•m)
3/4	146 ft / lb (198 N•m)	189 ft / lb (256 N•m)	226 ft / lb (306 N•m)	293 ft / lb (397 N•m)	319 ft / lb (432 N•m)	413 ft / lb (560 N•m)	160 ft / lb (217 N•m)	226 ft / lb (306 N•m)
7/8	142 ft / lb (193 N•m)	183 ft / lb (248 N•m)	365 ft / lb (495 N•m)	473 ft / lb (641 N•m)	515 ft / lb (698 N•m)	667 ft / lb (904 N•m)	258 ft / lb (350 N•m)	364 ft / lb (494 N•m)
1	213 ft / lb (289 N•m)	275 ft / lb (373 N•m)	547 ft / lb (742 N•m)	708 ft / lb (960 N•m)	773 ft / lb (1048 N•m)	1000 ft / lb (1356 N•m)	386 ft / lb (523 N•m)	545 ft / lb (739 N•m)



Warranty

MANUFACTURER'S LIMITED WARRANTY

BLUE DIAMOND® ATTACHMENTS, a manufacturer of quality attachments, warrants new BLUE DIAMOND® ATTACHMENTS products and/or attachments at the time of delivery to the original purchaser, to be free from defects in material and workmanship when properly set up and operated in accordance with the recommendations set forth by BLUE DIAMOND® ATTACHMENTS, LLC.

BLUE DIAMOND® ATTACHMENTS liability for any defect with respect to accepted goods shall be limited to repairing the goods at a BLUE DIAMOND® ATTACHMENTS designated location or at an authorized dealer location, or replacing them, as BLUE DIAMOND® ATTACHMENTS shall elect. The above shall be in accordance with BLUE DIAMOND® ATTACHMENTS warranty adjustment policies. BLUE DIAMOND® ATTACHMENTS obligation shall terminate twelve (12) months for the Severe Duty Nursery Fork after the delivery of the goods to original purchaser.

This warranty shall not apply to any machine or attachment which shall have been repaired or altered outside the BLUE DIAMOND® ATTACHMENTS factory or authorized BLUE DIAMOND® ATTACHMENTS dealership or in any way so as in BLUE DIAMOND® ATTACHMENTS judgment, to affect its stability or reliability, nor which has been subject to misuse, negligence or accident beyond the company recommended machine rated capacity.

WARRANTY CLAIM

To submit a warranty claim, a claim must be filed with BLUE DIAMOND® ATTACHMENTS before work is performed. The BLUE DIAMOND® PRODUCT SUPPORT TEAM will advise repairs and applicable parts exchanges. Tampering with the failed part may void the warranty. This warranty does not include freight or delivery charges incurred when returning machinery for servicing. Dealer mileage, service calls, and pickup/delivery charges are the customers' responsibility.

EXCLUSIONS OF WARRANTY

Except as otherwise expressly stated herein, BLUE DIAMOND® ATTACHMENTS makes no representation or warranty of any kind, expressed or implied, AND MAKES NO WARRANTY OF MERCHANTABILITY IN RESPECT TO ITS MACHINERY AND/OR ATTACHMENTS ARE FIT FOR ANY PARTICULAR PURPOSE. BLUE DIAMOND® ATTACHMENTS shall not be liable for incidental or consequential damages for any breach or warranty, including but not limited to inconvenience, rental of replacement equipment, loss of profits or other commercial loss. Upon purchase, the buyer assumes all liability for all personal injury and property resulting from the handling, possession, or use of the goods by the buyer.

No agent, employee, or representative of BLUE DIAMOND® ATTACHMENTS has any authority to bind BLUE DIAMOND® ATTACHMENTS to any affirmation, representation, or warranty concerning its machinery and/or attachments except as specifically set forth herein.

This warranty policy supersedes any previous documents.

NOTE: Blue Diamond® Attachments is a trademark of BLUE DIAMOND® ATTACHMENTS



QUALITY | DEPENDABILITY | INTEGRITY

Blue Diamond® Attachments
4512 Anderson Road, Knoxville, TN 37918
888-376-7027