

Landscape Rake

Operation and Maintenance Manual



- 433010 - 4 ft
- 433015 - 5 ft
- 433020 - 6 ft
- 433025 - 7 ft
- 433030 - 8 ft



Register your
WARRANTY
within 30 days
of purchase



888-376-7027 | BlueDiamondAttachments.com



BD-092

Owner Information

Thank you for your decision to purchase a Blue Diamond Landscape Rake. To ensure maximum performance of your equipment, it is mandatory that you thoroughly study the

Operator's Manual and follow the recommendations. Proper operation and maintenance are essential to maximize equipment life and prevent personal injury.

Operate and maintain this equipment in a safe manner and in accordance with all applicable local, state, and federal codes, regulations and /or laws. Follow all on-product labeling and instructions.

Make sure that all personnel have read this Operator's Manual and thoroughly understand safe and correct operating, installation and maintenance procedures.

Blue Diamond is continually working to improve its products. Blue Diamond reserves the right to make any improvements or changes as deemed practical and possible without incurring any responsibility or obligation to make any changes or additions to equipment sold previously.

Although great care has been taken to ensure the accuracy of this publication, Blue Diamond makes no warranty or guarantee of any kind, written or expressed, implied or otherwise with regard to the information contained within this manual. Blue Diamond assumes no responsibility for any errors that may appear in this manual and shall not be liable under any circumstances for incidental, consequential or punitive damages in connection with, or arising from the use of this manual.

Keep this manual available for frequent reference. All new operators or owners must review the manual before using the equipment and annually thereafter. Contact your Blue Diamond Attachments Dealer for assistance, information, or additional copies of the manual. Contact www.bluediamondattachments.com or call 888-376-7027 for a complete list of dealers in your area.

Serial Number Location

Please record attachment information in the space provided for future reference.



Model Number: _____

Serial Number: _____

Dealer Name: _____

Dealer Number: _____

Date of Purchase: _____

The serial number plate (is located on right side, just forward of the attachment mounting plate.

Always use your serial number when requesting information or when ordering parts.

NOTE: The directions left, right, front and rear, as mentioned throughout this manual, are as viewed from the operator's position.

Table of Contents

1. INTRODUCTION	6	7. SERVICE AND MAINTENANCE	23
1.1 Welcome	6	7.1 Maintenance Safety	23
1.2 Safe Operation	6	7.2 Tine Replacement	24
1.3 Specifications	7	7.3 Welding Repairs	24
1.4 Intended Usage	7	7.4 Bolt Torque Requirements	25
1.5 Operator Orientation	7	7.5 Service Record	26
1.6 Serial Number Location (Typical)	7		
1.7 Product Improvements	7	8. WARRANTY	27
1.8 Disposal of Equipment at End of Useful Life	7		
1.9 Unanswered Questions	7	9. PARTS	31
2. SAFETY	8		
2.1 General	8		
2.2 Safety Alert Symbols	8		
2.3 Safety Icon Nomenclature	9		
2.3.1 Personal Protection/Important Information	9		
2.3.2 Prohibited Actions	9		
2.3.3 Hazard Avoidance	9		
2.4 General Safety Instructions	10		
2.5 Training	11		
2.6 OSHA Training Requirements	11		
2.7 Operation Safety	11		
2.8 Transporting Safety	11		
2.9 Storage Safety	11		
2.10 Maintenance Safety	11		
2.11 Federal Laws and Regulations	12		
3. NOMENCLATURE	14		
4. OPERATION	15		
4.1 User Safety Training	15		
4.2 Tractor Requirements	16		
4.2.1 Tractor Safety Devices	16		
4.2.2 ROPS and Seat Belt	16		
4.2.3 3-Point Hitch	16		
4.3 Attaching to Tractor	17		
4.4 Setting the Landscape Rake	17		
4.4.1 Leveling the Landscape Rake	17		
4.4.2 Setting Rake Angle	18		
4.4.3 Rake Reversing (Pushing Rake)	18		
4.4.4 Setting Rake Pitch	18		
4.4.5 Setting Rake Tilt	18		
4.4.6 Checking Clearance to Tractor	18		
4.5 Initial Setup Checklist	18		
4.6 Implement Break-In	19		
4.6.1 General Operating Instructions	19		
4.7 Detaching From Tractor	20		
5. TRANSPORTING	21		
5.1 Transporting Safety (Road)	21		
6. STORAGE	22		
6.1 Storage Safety	22		
6.2 Placing In Storage	22		
6.3 Removing From Storage	22		

1. INTRODUCTION

1.1 Welcome

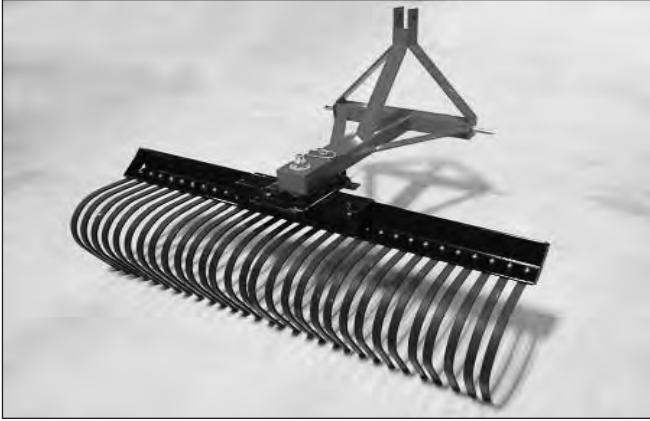

Landscape Rake

Congratulations on your choice of a Blue Diamond® Attachments landscape rake. This equipment has been designed and manufactured to meet the needs of discerning users.

The Blue Diamond® Attachments landscape rake is designed to loosen, level, and clear soil.

Many features incorporated into this landscape rake are the result of suggestions made by customers like you. Read this manual carefully to learn how to operate the landscape rake safely and how to adjust it to provide maximum operating efficiency.

1.2 Safe Operation

Safe, efficient, and trouble-free operation of your landscape rake requires that you, and anyone else who will be using or maintaining the unit, read and understand the information contained within this Manual.

Use this manual for reference and for new operators or owners.

! WARNING



Read And Understand Manual

To prevent personal injury or even death, be sure you read and understand all of the instructions in this manual and other related OEM equipment manuals! The landscape rake, if not used and maintained properly, can be dangerous to users unfamiliar with its operation. Do not allow operating, maintaining, adjusting, or cleaning of this landscape rake until the user has read this manual and has developed a thorough understanding of the safety precautions and functions of the unit.

This landscape rake is designed for the specific purpose of loosening, leveling, or clearing soil. DO NOT modify or use this landscape rake for any application other than that for which it was designed.

Landscape rakes maintained or operated improperly, or by untrained personnel, can be dangerous; exposing the user and/or bystanders to possible serious injury or death.

This manual covers Blue Diamond®
Landscape rake models:

Model	Working Width
433010	48"
433015	60"
433020	72"
433025	84"
433030	96"

1.3 Specifications

Model	4'	5'	6'	7'	8'
Horsepower Required	15-45	20-45	25-45	30-45	35-45
Working Width	48"	60"	72"	84"	96"
Tines per Foot	6				
Weight (Lbs.)	158	180	229	251	285
Mainframe	4" x 4" Angle				
Angle Adjustment	5 Position, Fwd & Rev				
A-Frame Material	3/8"				
Quick Hitch	YES				
Hitch	CAT I				

Specifications subject to change without notice.

1.4 Intended Usage

Do not use this landscape rake for any other purpose than its intended use of loosening, leveling, and clearing soil.

1.5 Operator Orientation

The directions left, right, front, and rear, as mentioned throughout this manual, are as seen from the tractor operator's seat and facing in the direction of travel.

1.6 Serial Number Location (Typical)

The serial number decal is located on the front of the frame.

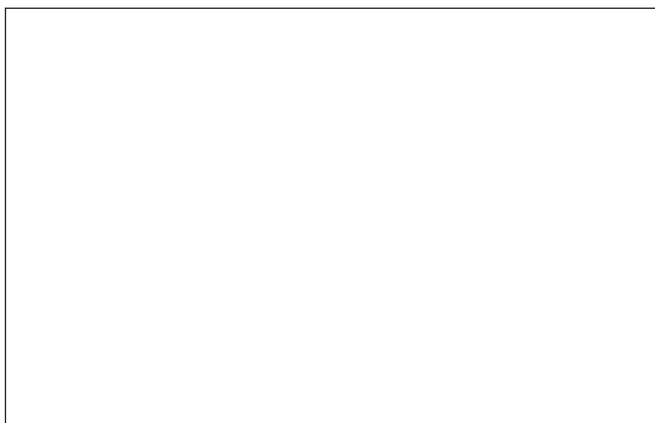

Model Number _____

Serial Number _____

1.7 Product Improvements

Because Blue Diamond® Attachments maintains an ongoing program of product improvement, we reserve the right to make improvements in design or changes in specifications without incurring any obligation to install them on units previously sold.

1.8 Disposal of Equipment at End of Useful Life

The Blue Diamond® Attachments landscape rake has been designed for the specific purpose of moving material for loosening, leveling, and clearing soil. When this unit is no longer capable of doing its designed purpose, it should be dismantled and scrapped. Do not use any materials or components from this unit for any other purpose.

1.9 Unanswered Questions

If you have any questions not answered in this manual, require additional copies, or the manual is damaged, please contact your dealer or:

Blue Diamond® Attachments

The manual is also available for download at: www.bluediamondattachments.com

1. Select "Products".
2. Select "Landscape Rakes".
3. Click the "Specs., Manuals, Warranty" tab.
4. Click "Download Manual".

2. Safety

2.1 General

Safety of the operator and bystanders is one of the main concerns in designing and developing a new piece of equipment. Designers and manufacturers build in as many safety features as possible. However, every year many accidents occur which could have been avoided by a few seconds of thought and a more careful approach to handling the equipment.

Most work-related accidents are caused by failure to observe basic safety rules or precautions. An accident can often be avoided by recognizing potentially hazardous situations before an accident occurs. As you assemble, operate, or maintain the landscape rake (unit), you must be alert to potential hazards. You should also have the necessary training, skills, and tools to perform any assembly or maintenance procedures.

Improper operation and maintenance of this unit could result in a dangerous situation that could cause injury or death.

If you have any questions not answered in this manual or require additional copies or the manual is damaged, please contact your dealer or:
Blue Diamond® Attachments

WARNING



Do not assemble, operate, or maintain the unit until you read and understand the information contained in this manual.



Safety precautions and warnings are provided in this manual. If these hazard warnings are not heeded, bodily injury or death could occur to you or to other persons.

Blue Diamond® Attachments cannot anticipate every possible circumstance that might involve a potential hazard. The warnings in this manual are, therefore, not all-inclusive. If a method of assembly, operation, or maintenance not specifically recommended by us is used, you must satisfy yourself that it is safe for you and for others. You should also ensure that the unit will not be damaged or be made unsafe by the methods that you choose.

The information, specifications, and illustrations in this manual are based on the information that was available at the time this material was written and can change at any time without notice.

2.2 Safety Alert Symbols



This is the safety alert symbol. It is used to alert you to potential personal injury hazards. Obey all safety messages that follow this symbol to avoid possible injury or death.

This manual contains DANGERS, SAFETY INSTRUCTIONS, CAUTIONS, IMPORTANT NOTICES, and NOTES which must be followed to prevent the possibility of improper service, damage to the equipment, personal injury, or death. The following key words call the readers' attention to potential hazards.

Hazards are identified by the "Safety Alert Symbol" and followed by a signal word such as "DANGER", "WARNING", or "CAUTION".

DANGER

Indicates an imminently hazardous situation which, if not avoided, will result in death or serious injury. This signal word is limited to the most extreme situations.

WARNING

Indicates a potentially hazardous situation which, if not avoided, could result in death or serious injury.

CAUTION

Indicates a potentially hazardous situation which, if not avoided, may result in minor or moderate injury.

NOTICE

Indicates that equipment or property damage can result if instructions are not followed.

SAFETY INSTRUCTIONS

Safety instructions (or equivalent) signs indicate specific safety-related instructions or procedures.

Note: Contains additional information important to a procedure.

2.3 Safety Icon Nomenclature

Pictorial icons signal a type of hazard and warn of personal protection issues, prohibited actions, and hazard avoidance.

2.3.1 Personal Protection/ Important Information







-  Read the manual
-  Maintenance procedure
-  Clear Vision
-  Eye protection
-  Fire extinguisher
-  First aid kit
-  Hand protection
-  Head protection
-  Hearing protection
-  Inspect equipment
-  OEM parts only
-  Protective shoes
-  Remove key
-  Set parking brake
-  Stop engine
-  Think safety
-  Transmission in park
-  Use proper support
-  Use proper tools

-  Visibility
-  Rollover protection
-  Wear seat belt
-  Weight rating

2.3.2 Prohibited Actions

-  Do not alter or modify
-  Use proper tools
-  Do not weld
-  No alcohol
-  No drugs
-  No smoking
-  No young children
-  No riders

2.3.3 Hazard Avoidance

-    Crush hazard
-  Crush hazard (chock wheels)
-  Crush hazard (foot)
-  Defective or broken part

-  Cutting edge contact hazard (hand)
-  Cutting edge contact hazard (foot)
-  Pinch point hazard
-  Rollover protection
-  Safety alert symbol
-  Sharp object hazard
-  Stay Clear
-  Slipping injury
-  Tripping injury

2.4 General Safety Instructions

The owner/operator is responsible for the SAFE use and maintenance of the landscape rake. Make sure anyone who is operating, maintaining, or working around the landscape rake is familiar with the operating and maintenance procedures and related SAFETY information contained in this manual. This manual will take you step-by-step through your working day and alerts you to all good safety practices that should be used while using the landscape rake.

In addition to the design features of the landscape rake, including safety signs, accident prevention is dependent upon the awareness, concern, prudence, and proper training of the people involved in the operation, maintenance, and storage of the landscape rake.

In addition to this safety section, refer also to safety messages and instructions in each of the appropriate sections of this manual.

These general safety instructions apply to the overall use and maintenance of the landscape rake.

More specific instructions on safety are found in the operation, maintenance, and storage sections of this manual. Refer to these sections before performing any of these tasks.

⚠ WARNING

Failure to comply with the following safety instructions could result in serious injury and possibly even death if they are not understood and followed.



Provide User with Literature
Blue Diamond® Attachments landscape rake owners must provide operator instructions to anyone using the landscape rake before use, and at least annually thereafter. Refer to “2.6 OSHA Training Requirements” on page 11.



Stay Clear
Clear the area of people, especially small children, before using the landscape rake. Under no circumstances should young children be allowed to work with or around the landscape rake.



Impaired User Hazard
Do not attempt to assemble, operate, or maintain this landscape rake under the influence of drugs or alcohol. Consult your doctor before using this landscape rake while taking prescription medications.

⚠ WARNING



Crush Hazard

Do not allow anyone to ride on the tractor or the landscape rake. Falling or crushing hazards can result in severe injuries or death.



Damaged Parts Hazard

Do not use the landscape rake if any parts are damaged. If the landscape rake has a defect, immediately stop using it and remedy the problem before continuing.

⚠ CAUTION

The following safety instructions are provided to help prevent potential injury. Not following these instructions could result in minor to moderate injury.

Personal Protection Equipment

When using this landscape rake, wear appropriate personal protective equipment. This list may include, but is not limited to:



- Protective shoes with slip resistant soles
- Protective goggles, glasses, or face shield
- Protective clothing and gloves
- Safety vest (when operating near roads)
- Hearing protection



Hearing Loss

Prolonged Exposure To Loud Noise May Cause Permanent Hearing Loss!

Working environments with noise-producing equipment can cause partial to permanent hearing loss. We recommend using hearing protection any time noise levels exceed 80 decibels (dB). Noise levels over 85 dB, on a long-term basis, can cause severe hearing loss. Noise levels over 90 dB over a period of time can cause permanent and even total hearing loss.

Hearing loss from loud noise is cumulative over a lifetime without hope of natural recovery.



Crush Hazard

The tractor should be equipped with a Roll Over Protective Structure (ROPS) and a seat belt. A crushing hazard can occur if the driver is ejected from the seat while the tractor is in motion. Fasten the seat belt whenever the tractor is moving.

SAFETY INSTRUCTIONS

The following safety instructions are provided to help prevent injury or limit equipment damage.



First Aid Kit

Have a first aid kit available for use should the need arise and know how to use it.



Fire Extinguisher

Have a fire extinguisher available for use should the need arise and know how to use it.



Think SAFETY!

Work SAFELY!

2.5 Training

Anyone who will be using and/or maintaining the landscape rake must read, clearly understand, and follow ALL safety, operation, and maintenance information presented in this manual and other related OEM manuals.

If you do not understand any information in this manual, see your dealer or contact Blue Diamond® Attachments before proceeding.

Do not use or allow anyone else to use this landscape rake until all information has been reviewed. Annually review this manual before the season start-up.

Make periodic reviews of SAFETY and OPERATION of the landscape rake a standard practice. An untrained operator is not qualified to use this landscape rake.

2.6 OSHA Training Requirements

The following training requirements have been taken from Title 29, Code of Federal Regulations Part 1928.57 (a) (6). www.osha.gov.

Operator instructions. At the time of initial assignment and at least annually thereafter, the employer shall instruct every employee who operates an agricultural tractor and implements in the safe operating practices and servicing of equipment with which they are or will be involved, and of any other practices dictated by the work environment.

2.7 Operation Safety

Refer to “4.1 User Safety Training” on page 15 for safety recommendations related to using the landscape rake. All applicable safety recommendations in other sections should also be followed.

2.8 Transporting Safety

Refer to “5.1 Transporting Safety (Road)” on page 21 for safety recommendations related to transporting the landscape rake. All applicable safety recommendations in other sections should also be followed.

2.9 Storage Safety

Refer to “6.1 Storage Safety” on page 22 for safety recommendations related to storing the landscape rake. All applicable safety recommendations in other sections should also be followed.

2.10 Maintenance Safety

Refer to “7.1 Maintenance Safety” on page 23 for safety recommendations related to maintaining the landscape rake. All applicable safety recommendations in other sections should also be followed.

2.11 Federal Laws and Regulations

IMPORTANT FEDERAL LAWS AND REGULATIONS CONCERNING EMPLOYERS, EMPLOYEES AND OPERATORS

This section is intended to explain in broad terms the concept and effect of the following federal laws and regulations. It is not intended as a legal interpretation of the laws and should not be considered as such.

U.S. PUBLIC LAW 91-596 (The Williams-Steiger Occupational Safety and Health Act of 1970) OSHA

This Act Seeks:

" ... to assure so far as possible every working man and woman in the nation safe and healthful working conditions and to preserve our human resources ... "

DUTIES

Sec. 5(a) Each Employer -

- (1) shall furnish to each of its employees employment and a place of employment which are free from recognized hazards that are causing or are likely to cause death or serious physical harm to its employees.
- (2) shall comply with occupational safety and health standards promulgated under this Act.
 - (b) Each employee shall comply with occupational safety and health standards and all rules, regulations, and orders issued pursuant to this Act which are applicable to his or her own actions and conduct.

OSHA Regulations

Current OSHA regulations state in part: "At the time of initial assignment and at least annually thereafter, the employer shall instruct every employee in the safe operation and servicing of all equipment with which the employee is, or will be involved." These will include (but are not limited to) instructions to:

Keep all guards in place when the machine is in operation;

Permit no riders on equipment;

Stop engine, disconnect the power source, and wait for all machine movement to stop before servicing, adjusting, cleaning, or unclogging the equipment, except where the machine must be running to be properly serviced or maintained, in which case the employer shall instruct employees as to all steps and procedures which are necessary to safely service or maintain equipment.

Make sure no one is within 300 feet of machinery before starting the engine, engaging power, or operating the machine.

EMPLOYEE TRACTOR OPERATING INSTRUCTIONS:

1. Securely fasten your seat belt if the tractor has a ROPS.
2. Where possible, avoid operating the tractor near ditches, embankments, and holes.
3. Reduce speed when turning, crossing slopes, and on rough, slick, or muddy surfaces.
4. Stay off slopes too steep for safe operation.
5. Watch where you are going, especially at row ends, on roads, and around trees.
6. Do not permit others to ride.
7. Operate the tractor smoothly - no jerky turns, starts, or stops.
8. Hitch only to the drawbar and hitch points recommended by tractor manufacturers.
9. When tractor is stopped, set brakes securely and use park lock if available.

Child Labor Under 16 Years Old

Some regulations specify that no one under the age of 16 may operate power machinery. It is your responsibility to know what these regulations are in your own area or situation. (Refer to U.S. Dept. of Labor, Employment Standard Administration, Wage & Home Division, Child Labor Bulletin #102).

3. Nomenclature

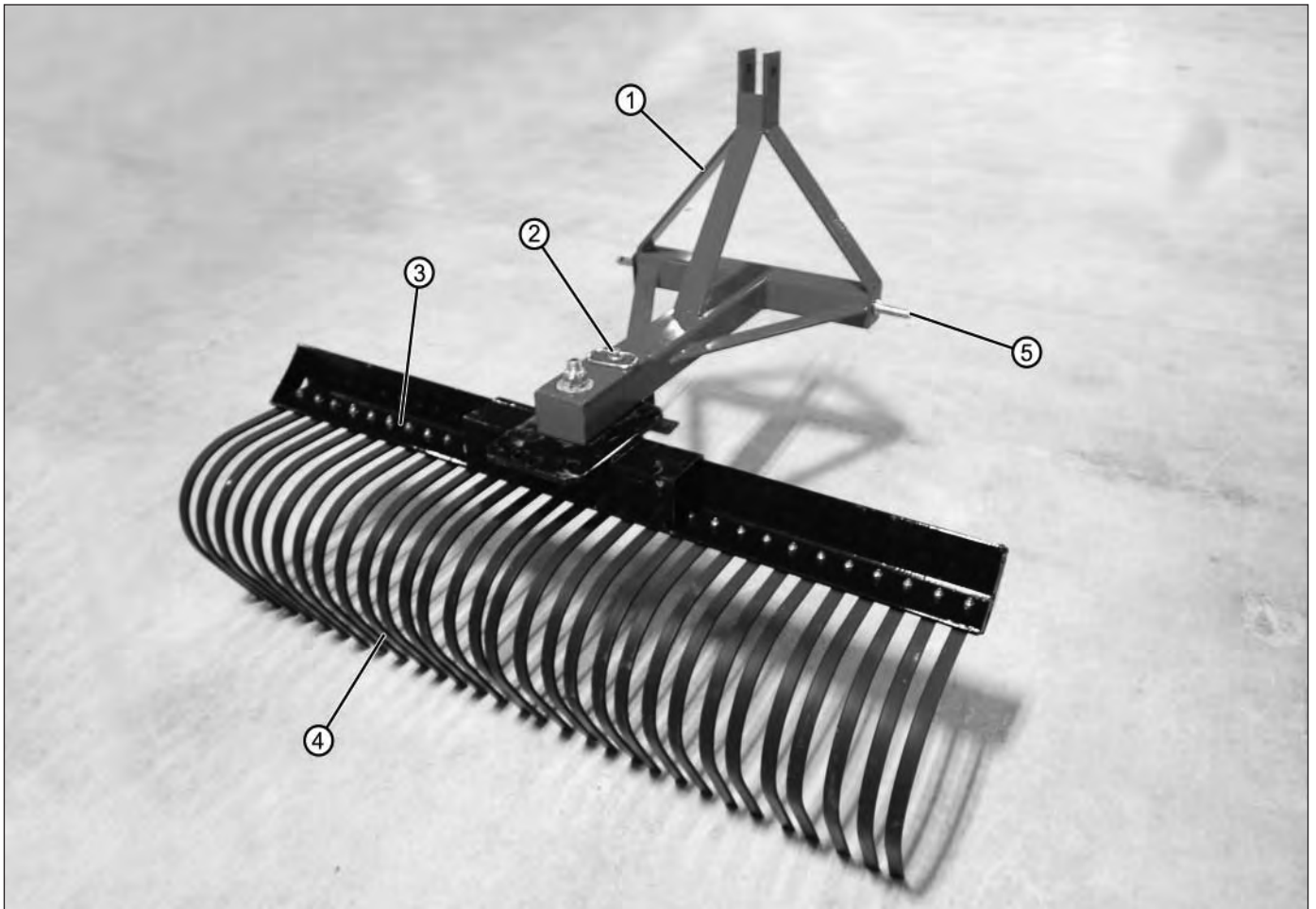

Item	Description
1	A-Frame
2	Angle Adjustment Pin
3	Rake Bottom
4	Tines
5	CAT I 3-Point Hitch Pins

4. Operation

4.1 User Safety Training

Refer to “2.4 General Safety Instructions” on page 10 for general user safety training requirements.

WARNING



Roll Away Hazard
Before leaving the tractor seat, make sure the engine is stopped, the transmission is placed in park, the key is removed, and the parking brake is set.



The weight of the tractor, plus the implement, if it rolls onto a person, can cause serious crushing injury or death.



Crush Hazard
The tractor should be equipped with a Roll Over Protective Structure (ROPS) and a seat belt. A crushing hazard can occur if the driver is ejected from the seat while the tractor is in motion. Fasten the seat belt whenever the tractor is moving.



Stay Clear

Clear the work area of all unnecessary people and obstructions to prevent personal injury.



Tine Contact Hazard (hand)

To avoid serious injury or death, keep away from ground engaging components. Do not put hands under landscape rake.



Tine Contact Hazard (foot)

To avoid serious injury or death, keep away from ground engaging components. Do not put feet under landscape rake.



Operating the Tractor

Before attaching the landscape rake to the tractor, be familiar with its controls and how to stop quickly in the event of an emergency. Read and understand this manual and the one provided with your tractor before operating the landscape rake.

SAFETY INSTRUCTIONS

The following safety instructions are provided to help prevent injury or limit equipment damage.



Train Unfamiliar Users

It is the landscape rake owner's responsibility to make sure any person using the landscape rake, especially if it is loaned or rented, has been thoroughly trained on its proper and safe use.

Be certain only physically-able persons will use the landscape rake.

Untrained users expose themselves and bystanders to possible serious injury or death.

If the elderly are assisting with the work, their physical limitations need to be recognized and accommodated.

Never allow children to operate equipment.

4.2 Tractor Requirements



WARNING



Tractor Owner/Operator Manual
Always refer to the tractor Operator's Manual to ensure compatibility and maximum safety.

The tractor used to operate the landscape rake must have the power capacity to lift and pull the landscape rake at a ground speed between 2 and 5 MPH.

Use the chart to select the tractor horsepower appropriate for your landscape rake. Do not use a tractor of more than the recommended HP to prevent damaging landscape rake components.

Model	Recommended HP
433010-4'	15-45
433015 - 5'	20-45
433020 - 6'	25-45
433025-7'	30-45
433030 - 8'	34-45

The tractor must be matched to the weight of the landscape rake. A minimum of 20% of the combined tractor and equipment weight should be on the front wheels. This will ensure adequate stability during transport and operation.

Always review the "controls" section of the tractor Operator's Manual to be familiar with the location, settings, and function of the tractor controls. Be familiar with all controls before using this equipment.

4.2.1 Tractor Safety Devices

If transporting or operating the tractor and implement near a public roadway, the tractor must be equipped with proper warning lighting and a Slow Moving Vehicle (SMV) emblem, which are clearly visible from the rear of the unit. Lights and a SMV emblem must be attached directly to the implement if the visibility of the tractor warning signals is obscured.

Never operate the tractor PTO with the PTO master shield missing or in the raised position.

4.2.2 ROPS and Seat Belt

WARNING



Rollover Hazard

To avoid serious injury or death from falling off tractor, equipment rollover, rollover, or crushing:

- 1) Use ROPS equipped tractor.
- 2) Keep ROPS locked in the UP position.
- 3) Only operate the equipment when seated in the tractor seat.
- 4) Always fasten seat belt when operating the tractor and landscape rake.

The tractor must be equipped with a Roll Over Protective Structure (ROPS) (tractor cab or roll-bar) and seat belt to protect the operator from falling off the tractor, especially during a roll-over where the driver could be crushed and killed. Only operate the tractor with the ROPS in the raised position and seat belt fastened.

4.2.3 3-Point Hitch

These landscape rakes are designed to be mounted on a tractor CAT I 3-Point or Quick Hitch.

Refer to the tractor Operator's Manual for the category of the tractor being used. If the hitch does not conform to ASABE CAT I dimensions, the landscape rake may not fit or raise properly. Consult an authorized dealer for possible modification procedures to mount non-conforming hitches. Depending on the hitch category, certain size pins are used to attach the implement to the tractor. CAT I hitches require 7/8" lower and 3/4" upper diameter hitch pins.

Install the lift arm stabilizer or shorten the stop chains to place the arms into the non-sway configuration. Refer to the tractor manual for details.

4.3 Attaching to Tractor

Use caution when connecting the landscape rake to the tractor. The landscape rake should be securely resting on the ground or setting on blocks. Keep hands and feet away from the tines and clear of pinch points between the tractor hitch arms and landscape rake hitch pins.

WARNING



Crush Hazard

Crush hazard between hitch and implement. Do not allow anyone to stand between the hitch and implement during hook-up operations. Never operate the hydraulic 3-point lift controls while someone is directly behind the tractor.

1. Shorten or remove the tractor drawbar to avoid interference when raising and lowering the landscape rake.
 2. Board the tractor and start the engine. Position the tractor with the 3-point lift arms positioned at the same height and to the outside of the landscape rake hitch pins.
- Note:** Set the 3-point lift control to “Position Control” so that the lift arms maintain a constant height when attaching the landscape rake. See the tractor Operator’s Manual for correct settings when attaching 3-point equipment.
3. Turn off the tractor engine and dismount.
 4. One lift arm at a time, insert hitch pin through the lift arm holes and install retaining pin.
 5. Walk around to the opposite side and repeat the procedure for the remaining lift arm and hitch pin.
 6. Extend or retract the 3-point top link to align its end hole with the hole of the landscape rake’s top link. Insert the top link hitch pin and insert the retaining pin into the hitch pin.
 7. Adjust any lower link check chains, guide blocks, or sway blocks to prevent the landscape rake from swaying side-to-side and possible contact with the tractor rear tires.

4.4 Setting the Landscape Rake

Properly setting the landscape rake is essential for efficient and safe operation. A properly set landscape rake will loosen, level, and clear the soil evenly, while requiring minimal tractor work.

Note: The landscape rake must be attached to the tractor and raised off the ground to make the following adjustments.

WARNING



Crush Hazard

Make adjustments to the landscape rake after it has been properly attached to the tractor and secured with solid supports.

Never work around equipment supported by hydraulics.

Hydraulics can drop equipment instantly if controls are actuated, or if hydraulic lines burst even when power to the hydraulics is shut off.



Unexpected Movement Hazard

When the adjustment pins are removed, the landscape rake may swing downhill, resulting in severe injury or death from crushing or pinching. Park the tractor on level ground before making any adjustments. Stay clear of moving parts. Keep fingers away from adjustment holes.

4.4.1 Leveling the Landscape Rake

1. Use the adjustment on the tractor 3-point hitch lift arm to level the landscape rake from side-to-side.
2. Adjust the top link to level the landscape rake from front-to-back.

4.4.2 Setting Rake Angle

1. On all models, holes are provided for angling the landscape rake on each side of center in 15° increments up to 30°.
2. Remove the hairpin and clevis pin, swing the landscape rake left or right to the desired position, and re-install the pin and hairpin.



4.4.3 Rake Reversing (Pushing Rake)

1. On all models, holes are provided for angling the landscape rake in the reverse position on each side of center in 15° increments up to 30°.
2. Remove the hairpin and clevis pin, rotate the landscape rake 180° to the desired reverse position, and re-install the pin and hairpin.

4.4.4 Setting Rake Pitch

1. Pitch can be adjusted by lengthening or shortening the tractor's top center 3-point link. Increasing the pitch will increase the landscape rake's ability to dig.
2. Lengthen the center 3-point link to increase the landscape rake pitch while traveling forward. Shorten the center 3-point link to decrease the pitch.
3. If backfilling, shorten the center 3-point link to increase the landscape rake pitch and lengthen the center 3-point link to decrease the pitch.
4. To help protect the landscape rake from damage while backfilling, lengthen the tractor's center 3-point link until the landscape rake moves across the top of the ground without forcing itself into the soil.

4.4.5 Setting Rake Tilt

The landscape rake may be tilted so one end is lower than the other by adjusting the tractor's lower 3-point arms.





4.4.6 Checking Clearance to Tractor

5. Raise the landscape rake off the ground and angle it as far as possible towards the right rear tractor tire. Refer to "4.4.2 Setting Rake Angle" on page 18.
6. Return to the tractor and slowly raise the 3-point lift arms fully up and down to make sure the landscape rake does not contact the tractor tire, drawbar, or any other equipment on the tractor.
 - a. Move or remove the drawbar if it interferes with the landscape rake.
 - b. Set the tractor control lever stop to restrict lifting height if the landscape rake interferes with the tractor tire.

4.5 Initial Setup Checklist

Efficient and safe operation of the landscape rake requires that every user read and understand the operational instructions and all related safety instructions outlined in this manual.

This checklist is provided for the user/owner. It is important for both personal safety and to maintain the mechanical condition of the landscape rake that this checklist is followed.

Initial Setup Checklist (prior to using for the first time)		
✓	Location	Task
		Make sure the landscape rake is properly mounted to the 3-point hitch. Refer to "4.3 Attaching to Tractor" on page 17.
		Make sure all hardware is properly installed and tightened. Refer to "7.4 Bolt Torque Requirements" on page 25.
		Check the condition of the Tines. Refer to "7.2 Tine Replacement" on page 24.
		Check the landscape rake setup. Adjust if needed. Refer to "4.4 Setting the Landscape Rake" on page 17.

4.6 Implement Break-In

Although there are no operational restrictions on the landscape rake when used for the first time, it is recommended that the following mechanical items be checked:

1. After 1/2 hour of operation:
 - a. Check all fasteners and tighten if necessary.
 - b. Make sure that the tines are in good condition.
2. After 10 hours of operation:
 - a. Go to the normal servicing and maintenance schedule, as defined in the Maintenance Section.

4.6.1 General Operating Instructions

Operate the landscape rake only in conditions where you have clear visibility in daylight or with adequate artificial lighting. Never operate the landscape rake in darkness or foggy conditions where you cannot clearly see at least 300 feet.

Inspect the landscape rake for potential problems or damage. Do not use the landscape rake if it needs repairs of any type. Use only an appropriately sized tractor to pull the landscape rake. Refer to "4.2 Tractor Requirements" on page 16. When transporting or travelling to and from work sites, make sure that the landscape rake is in the fully raised position and not in contact with the ground. Select a safe speed and transport to your work site in such a manner that faster moving vehicles can pass you safely. A slow moving vehicle sign should be employed when using a public road or right-of-way.

Thoroughly inspect the work area for stones, branches, debris, buried utility cables, pipelines, sprinkler heads, and any other hard objects that may be struck. Never operate the landscape rake in an area that you have not inspected and removed debris or foreign material. Clear the area of bystanders, especially small children. Make sure that you can clearly see and identify passersby, steep slopes, ditches, and drop-offs. Also make certain that all irrigation heads, utility outlets, and other obstacles that cannot be removed are properly marked. Watch for trees, low hanging limbs, power lines, and other overhead obstacles while you are operating. Use care to avoid hitting these items. If you are unable to clearly see these type of items, discontinue operating the landscape rake.

Do not operate the landscape rake, or drive the tractor into material that is burning, or areas that recently burnt and may contain hot spots. Tire damage can occur when driving over hot material. Oil and grease on the tractor and landscape rake could ignite, resulting in equipment destruction.

At the work site, lower the landscape rake with the 3-point hitch control lever so that it is just barely off the ground. Lock the tractor brake to prevent rolling, shut off the tractor, and remove the ignition key before dismounting. Make the necessary angle and pitch adjustments to the landscape rake to achieve the desired results.

- Changing the landscape rake angle to left or right will distribute extraneous and oversized material in furrows to the left or right.
- Increasing the pitch angle of the landscape rake by lengthening the top link will make the landscape rake more aggressive on the soil.
- Decreasing the pitch angle of the landscape rake by shortening the top link will make the landscape rake less aggressive on the soil.

After making the initial adjustments and settings, board the tractor and select a gear and engine rpm that will produce a ground speed safe and suitable for the ground and operating conditions. Lower the landscape rake into operating position and begin working. Make any additional adjustments as needed. Some experimentation may be needed to achieve the desired results. Always operate safely and follow all the instructions in this manual.

4.7 Detaching From Tractor

1. Move the landscape rake to a level storage location. Park the tractor, place the transmission in park or neutral, and apply the parking brake. Lower the landscape rake, shut down the engine, and remove the key before exiting the tractor.
2. Make sure the landscape rake is resting securely on the ground and the hitch frame is on blocks before attempting to disconnect it from the tractor.

WARNING



Crush Hazard

Keep feet and hands from under the landscape rake and clear of any pinch points caused by the tractor hitch arms and landscape rake hitch pins. Never operate the hydraulic 3-point lift controls while someone is directly behind the tractor.

3. Extend or retract the tractor 3-point hitch top link to remove tension on the top link hitch pin. When the pin is loose and easy to rotate, remove the pin from the landscape rake. Disconnect the lift arms.



Note: Support stand not included.

5. Transporting

5.1 Transporting Safety (Road)

Refer to “2.4 General Safety Instructions” on page 10 for general transporting safety requirements.

WARNING

The following safety instructions are provided to help prevent serious injury and possibly even death.



Operating the Tractor

Before attaching the landscape rake to the tractor, be familiar with its controls and how to stop quickly in the event of an emergency. Read and understand this manual and the one provided with your tractor before transporting the landscape rake.

SAFETY INSTRUCTIONS

The following safety instructions are provided to help prevent injury or limit equipment damage.



Drive Safely

Be a safe and courteous driver. Anticipate what other drivers will do and drive accordingly.



Allow Extra Distance

Apply brakes early. Leave extra distance between your vehicle and the one(s) ahead to provide adequate stopping space. Extra distance will be required to stop the vehicle.



Clear Vision

Remove all objects from the area that would prevent clear vision of the complete work area or would present an obstacle when moving the landscape rake.



Hitch Attachment

Be sure the landscape rake is securely attached to the tractor and in good operating condition before using.



Working Taillights

Make sure lights on the tractor are working properly.



Hazard Flashers

Use hazard flashers on the tractor when transporting unless prohibited by law.



Right-of-Way

When travelling below the posted speed limit, keep to the right and yield the right-of-way to allow faster traffic to pass.

SAFETY INSTRUCTIONS



Tractor Owner/Operator Manual

Always refer to the tractor Operator’s Manual to determine its compatibility and maximum safety.



Maximum Transporting Speed

Do not exceed 20 MPH when transporting the landscape rake. Slow down for corners and rough terrain.



Visibility

Clean reflectors, SMV or SIS sign, and lights before transporting. Make sure all the lights and reflectors required by highway and transport authorities are in place and can be seen clearly by all overtaking and oncoming traffic.



Additional Lighting

For dual edge scrapers without lights, install additional lights on the rear of the tractor to safeguard against rear-end collisions. Daybreak and dusk are particularly dangerous and rear pilot vehicles are recommended. Implements without lights should be transported on public roads only during daylight hours.



Regulations

Make sure all local, state, and federal regulations, regarding the transport of equipment on public roads and highways, are met. Check with the local authorities regarding transporting the landscape rake on public roads. Obey all applicable laws and regulations.

6. Storage

6.1 Storage Safety

At the end of the season, the landscape rake should be thoroughly inspected and prepared for storage. Repair or replace any worn or damaged components to prevent any unnecessary downtime at the beginning of the next season.

CAUTION



Personal Injury Hazard

Store the landscape rake in an area away from human activity. To prevent the possibility of serious injury, do not permit children to play on or around the stored landscape rake.

NOTICE

To prevent damage to the landscape rake, store it in a dry, level area.

6.2 Placing In Storage

1. Remove all entangled vegetation and debris.
2. Thoroughly wash the landscape rake with a pressure washer or water hose to remove all dirt, mud, or debris.
3. Select an area that is dry, level, and free of debris (inside a building is ideal). Move the landscape rake to its storage area.
4. Lower the landscape rake onto the ground with the hitch frame on blocks.
5. Disconnect the landscape rake from the 3-point hitch and drive the tractor away from the landscape rake. Refer to “4.7 Detaching From Tractor” on page 20. Do not leave the tractor attached to the landscape rake.
6. Touch up all paint nicks and scratches to prevent rusting.

6.3 Removing From Storage

When removing the landscape rake from storage, follow this procedure:

1. Before placing the landscape rake back into service, replace any worn or defective parts and perform the Pre-Operation Checklist.
2. Attach the landscape rake to the tractor 3-point hitch. Refer to “4.3 Attaching to Tractor” on page 17.
3. Raise the landscape rake up off the blocks.

7. Service and Maintenance

7.1 Maintenance Safety

WARNING

The following safety instructions are provided to help prevent serious injury and possibly even death.



Damaged Parts Hazard

Do not use the landscape rake if any parts are damaged. If the landscape rake is believed to have a defect which could cause it to work improperly, immediately stop using it and remedy the problem before continuing.



No Unauthorized Modifications

Do not modify the landscape rake or safety devices. Do not weld on the unit. Unauthorized modifications may impair its function and safety and will void the warranty.

If the landscape rake has been altered in any way from the original design, the manufacturer does not accept any liability for injury or warranty.



Crush Hazard

Landscape rake components are very heavy and can injure a person should they suddenly fall from a lifting device or improvised supports. Always make certain components are properly secured before lifting and properly supported on the ground before removing lifting device. Always keep feet and other extremities clear of areas where components can fall.



Good Working Condition

Keep all parts in good condition and properly installed. Fix damage immediately. Replace worn or broken parts.



Replacement Parts

If replacement parts are necessary, genuine factory replacement parts must be used to restore the unit to its original specifications. Titan Implement will not accept responsibility for damages as a result of the use of unapproved parts.

SAFETY INSTRUCTIONS

The following safety instructions are provided to help prevent injury or limit equipment damage.



Clean Work Area

Do not leave tools lying around the work area. Follow good shop practices. Keep service area clean and dry. Be sure electrical outlets and tools are properly grounded. Use adequate light.



Use the Right Tools

Use the correct tools, jacks, hoists, or other tools that have the capacity for the job.



Proper Support

Use certified safety stands rated to support the load when performing repairs, service, or maintenance.

If the landscape rake is not attached to the tractor, place it on blocks or jack stands before performing repairs, service, or maintenance.

If the landscape rake is attached to the tractor, set the brakes, remove the key, chock the tractor wheels, and block the landscape rake before performing repairs, service, or maintenance.

Tighten the lower 3-point arm anti-sway mechanism to prevent side-to-side movement.

7.2 Tine Replacement

The tines are subject to damage and wear. They will require replacement when they become damaged or excessively worn.

1. Remove the 3/8 x 1-1/4" tine retaining bolt from the tine being replaced.



2. Loosen the remaining bolts in the hold-down plate.

Note: Each hold-down plate holds six tines. It may be necessary to loosen all the bolts in the hold-down plate to remove an individual tine.

3. Slide the tine out from under the tine hold-down plate.
4. Install the replacement tine and tighten the bolt. Tighten any other bolt that was loosened.

7.3 Welding Repairs



Before performing any type of welding repair to the landscape rake, contact Titan Implement for approval. Repair welding must be done with care and with procedures that may be beyond the capabilities of the ordinary welder.

WARNING



Personal Injury Hazard
Repairs or modifications to the landscape rake can result in serious injury or death should these repairs fail.

NOTICE

Anyone performing a welding repair should be certified in accordance to the American Welding Society (AWS) standards.

7.4 Bolt Torque Requirements

It is extremely important to apply and maintain proper torque on all bolts. Use a torque wrench to assure the proper amount of torque is being applied to the fastener. Start all bolts or nuts by hand to prevent cross threading.

Torque figures indicated in the chart are used for non-greased or non-oiled threads and heads unless otherwise specified. Therefore, do not grease or oil bolts or cap screws unless otherwise specified in this manual. When using locking elements, increase torque values by 5%.





The chart below gives correct torque values for various bolts and cap screws. Tighten all bolts to the torque specified in the charts unless otherwise noted. Check tightness of bolts periodically, using the bolt torque chart as a guide. Always replace hardware with the same Grade bolt.

⚠ WARNING

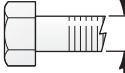

EQUIPMENT FAILURE

The torque value for bolts and cap screws are identified by their head markings. Replacing higher "Grade" bolts (Grade 5) with lower Grade bolts will lead to equipment failure and can result in injury or death. Always use replacement bolts with the same Grade markings as the removed bolt.

Bolt Diameter 	English Bolt Torque Specifications					
	Grade 2  No Marking		Grade 5  3 Radial Lines		Grade 8  6 Radial Lines	
	N·m	ft.lbs.	N·m	ft.lbs.	N·m	ft.lbs.
1/4"	8	6	12	9	17	12
5/16"	13	10	25	19	36	27
3/8"	27	20	45	33	63	45
7/16"	41	30	72	53	100	75
1/2"	61	45	110	80	155	115
9/16"	95	60	155	115	220	165
5/8"	128	95	215	158	305	220
3/4"	225	165	390	290	540	398
7/8"	230	170	570	420	880	650
1"	345	225	850	630	1320	970

7.5 Service Record

The period recommended is based on normal operating conditions. Severe or unusual conditions may require more frequent service.

Copy this page to continue record.

Hours and Serviced By																		
Maintenance																		
Before Each Use																		
Make sure all retainer clips and cotter pins are in place.																		
Inspect the tines for wear and damage.																		
Annually																		
Make sure all fasteners are properly tightened.																		
Inspect the tines for wear and damage.																		
Make sure the 3-point hitch pins and retainer clips are in good condition. Do not use homemade or shop-made pins.																		
Inspect the hitch A-frame and braces for wear and damage.																		
Wash the landscape rake.																		

9. Parts

Replacement parts are available from your BDAParts.com

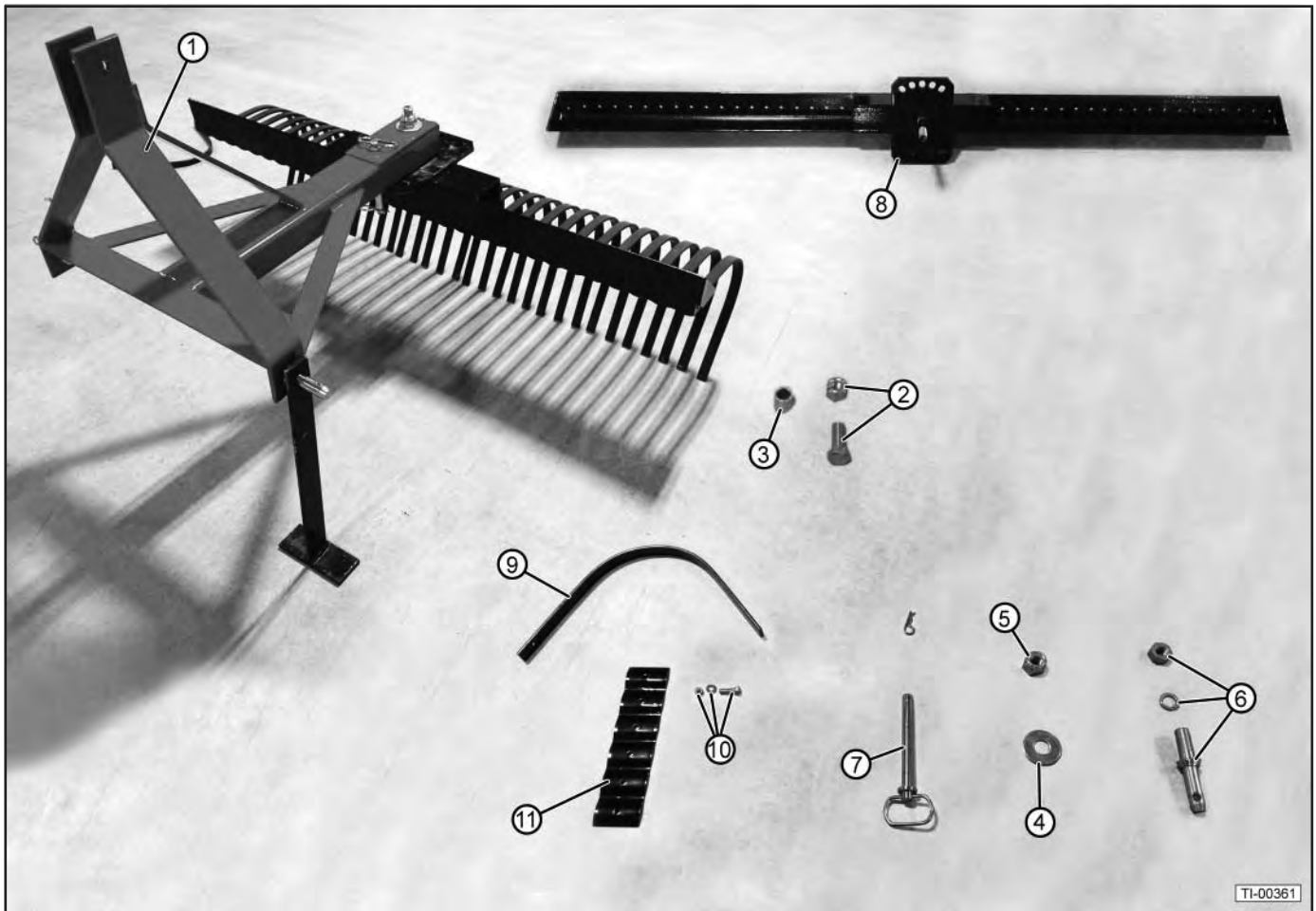

Item	Part Number	Description	Qty.
1	510000	A-Frame, Standard	1
2	110027	A-Frame Top Front Bolt & Locknut Kit, 3/4" x 4-1/2"	1
3	110030	A-Frame Spacer, 2"	1
4	410002	A-Frame to Bottom Washer (1")	1
5	410003	A-Frame to Bottom Nylon Lock Nut (1")	1
6	110032	Lift Pin Kit, CAT I	2
7	410004	Top Link Pin	1

Item	Part Number	Description	Qty.
8	510002	Rake Bottom, 4'	1
	510003	Rake Bottom, 5'	
	510004	Rake Bottom, 6'	
	510005	Rake Bottom, 7'	
	510006	Rake Bottom, 8'	
9	510007	Rake Tine	A/R*
10	510008	Rake Tine Bolt, Washer, & Nut Kit, 3/8 x 1-1/4"	A/R*
11	510009	Rake Tines Hold Down	A/R*

* As Required



MANUFACTURER'S LIMITED WARRANTY

BLUE DIAMOND ATTACHMENTS, a manufacturer of quality attachments, warrants new BLUE DIAMOND ATTACHMENTS products and/or attachments at the time of delivery to the original purchaser, to be free from defects in material and workmanship when properly set up and operated in accordance with the recommendations set forth by BLUE DIAMOND ATTACHMENTS, LLC.

BLUE DIAMOND ATTACHMENTS liability for any defect with respect to accepted goods shall be limited to repairing the goods at a BLUE DIAMOND ATTACHMENTS designated location or at an authorized dealer location, or replacing them, as BLUE DIAMOND ATTACHMENTS shall elect. The above shall be in accordance with BLUE DIAMOND ATTACHMENTS warranty adjustment policies. BLUE DIAMOND ATTACHMENTS obligation shall terminate twelve (12) months for the Landscape Rake after the delivery of the goods to original purchaser.

This warranty shall not apply to any machine or attachment which shall have been repaired or altered outside the BLUE DIAMOND ATTACHMENTS factory or authorized BLUE DIAMOND ATTACHMENTS dealership or in any way so as in BLUE DIAMOND ATTACHMENTS judgment, to affect its stability or reliability, nor which has been subject to misuse, negligence or accident beyond the Company recommended machine rated capacity.

WARRANTY CLAIM

To submit a warranty claim, a return authorization from BLUE DIAMOND ATTACHMENTS must be obtained. The failed part may then be returned. Tampering with the failed part may void the warranty. This warranty does not include freight or delivery charges incurred when returning machinery for servicing. Dealer mileage, service calls, and pickup/delivery charges are the customers' responsibility.

EXCLUSIONS OF WARRANTY

Except as otherwise expressly stated herein, BLUE DIAMOND ATTACHMENTS makes no representation or warranty of any kind, expressed or implied, AND MAKES NO WARRANTY OF MERCHANTABILITY IN RESPECT TO ITS MACHINERY AND/OR ATTACHMENTS ARE FIT FOR ANY PARTICULAR PURPOSE. BLUE DIAMOND ATTACHMENTS shall not be liable for incidental or consequential damages for any breach or warranty, including but not limited to inconvenience, rental of replacement equipment, loss of profits or other commercial loss. Upon purchase, the buyer assumes all liability for all personal injury and property resulting from the handling, possession, or use of the goods by the buyer.

No agent, employee, or representative of BLUE DIAMOND ATTACHMENTS has any authority to bind BLUE DIAMOND ATTACHMENTS to any affirmation, representation, or warranty concerning its machinery and/or attachments except as specifically set forth herein.

This warranty policy supersedes any previous documents.

NOTE: Blue Diamond Attachments is a trademark of BLUE DIAMOND ATTACHMENTS, LLC.



QUALITY | DEPENDABILITY | INTEGRITY

Blue Diamond® Attachments
4512 Anderson Road, Knoxville, TN 37918
88-376-7027