

Heavy Duty Land Grader

Operation And Maintenance Manual



Register your
WARRANTY
within 30 days
of purchase



888-376-7027 | BlueDiamondAttachments.com



BD-092

Introduction: Owner Information

Thank you for your decision to purchase a Blue Diamond Heavy Duty Land Grader. To ensure maximum performance of your equipment, it is mandatory that you thoroughly study the Operator's manual and follow the recommendations. Proper operation and maintenance are essential to maximize equipment life and prevent personal injury.

Operate and maintain this equipment in a safe manner and in accordance with all applicable local, state, and federal codes, regulations and /or laws. Follow all on-product labeling and instructions.

Make sure that all personnel have read this Operator's Manual and thoroughly understand safe and correct operating, installation and maintenance procedures.

Blue Diamond is continually working to improve its products. Blue Diamond reserves the right to make any improvements or changes as deemed practical and possible without incurring any responsibility or obligation to make any changes or additions to equipment sold previously.

Although great care has been taken to ensure the accuracy of this publication, Blue Diamond makes no warranty or guarantee of any kind, written or expressed, implied or otherwise with regard to the information contained within this manual. Blue Diamond assumes no responsibility for any errors that may appear in this manual and shall not be liable under any circumstances for incidental, consequential or punitive damages in connection with, or arising from the use of this manual.

Keep this manual available for frequent reference. All new operators or owners must review the manual before using the equipment and annually thereafter. Contact your Blue Diamond Attachments Dealer for assistance, information, or additional copies of the manual. Contact www.bluediamondattachments.com or call 888-376-7027 for a complete list of dealers in your area.

Serial Number Location:

Please record attachment information in the space provided for future reference.

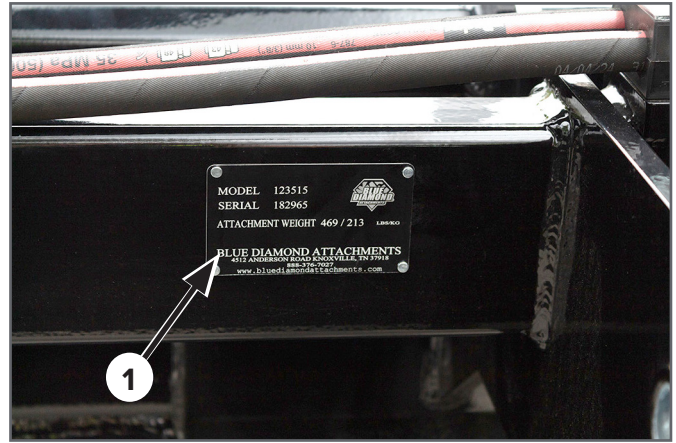

Model Number: _____

Serial Number: _____

Dealer Name: _____

Dealer Number: _____

Date of Purchase: _____

The serial number plate (Item 1) is located on the rear of the frame facing the mount.

Always use your serial number when requesting information or when ordering parts.

NOTE: The directions left, right, front, and rear, as mentioned throughout this manual, are as viewed from the operator's position.

Table of Contents

Introduction: Owner Information	2
1. Introduction.....	4
1.1 Attachment Identification.....	4
2. Safety	5
2.1 General Safety Information.....	5
3. Inspection and Setup.....	8
3.1 General Information.....	8
3.2 Inspection	9
3.3 Setup	10
3.4 Installation With Skid-Steer Loader	11
4. Operation	14
4.1 Land Grader Operation	14
5. Maintenance.....	18
5.1 Maintenance Safety	18
5.2 Maintenance Items.....	19
5.3 Removal And Replacement.....	20
5.4 Storage And Return To Service	21
6. Parts.....	22
6.1 Main Land Grader Parts.....	22
6.2 Main Land Grader Parts - 2.....	24
6.3 Blade Assembly Parts.....	25
6.4 Quicktach & Tilt Stop Parts.....	26
6.5 Mount Parts.....	27
6.7 Lift Wheel Linkage Parts.....	28
6.8 Wheel Pivot & Wheel Axle Parts.....	29
6.9 Hydraulic Block & Control Box Bracket	31
6.10 Hydraulic Valve Assembly	32
6.11 Hydraulic Hose Kit.....	33
6.12 Hydraulic Schematic.....	35
6.13 Masts & Manual Canister Parts.....	36
6.14 Decals	38
6.15 Laser Controller And Receivers	39
6.16 Baseline Settings for 123500 Laser Kit	40
6.17 Controller Settings - 123500	41
6.17 Controller Settings - 123500	42
7. Specifications.....	43
7.1 Attachment Specifications.....	43
7.2 Torque Specifications.....	44
Warranty.....	45

1. Introduction

1.1 Attachment Identification

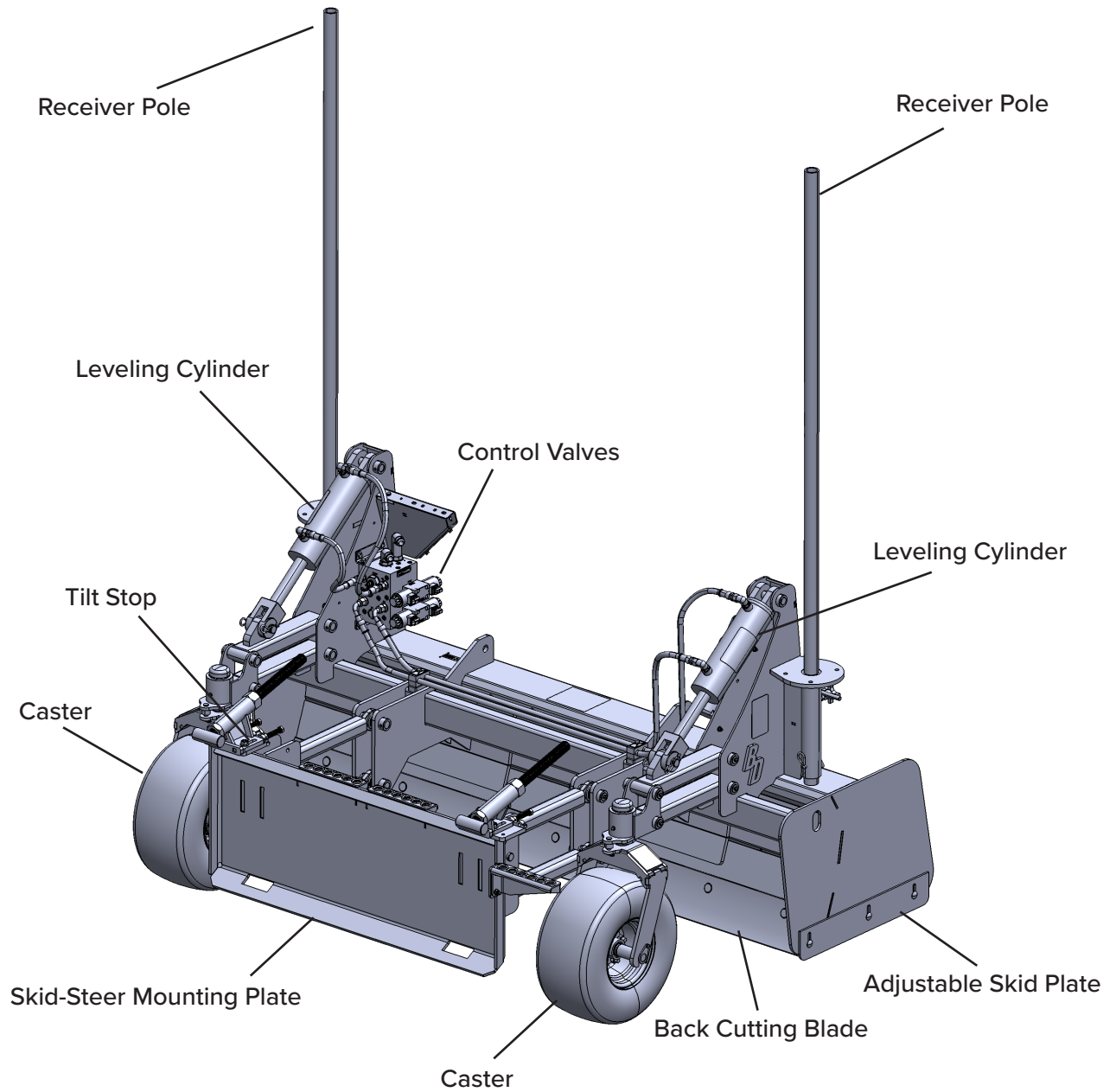

2. Safety

2.1 General Safety Information



This **SAFETY ALERT SYMBOL** identifies important safety messages on the equipment and in the owner's manual. When you see this symbol, be alert to the possibility of personal injury and carefully read the message that follows.



The signal word **DANGER** on the machine and in the manuals indicates a hazardous situation which, if not avoided, will result in death or serious injury.



The signal word **WARNING** on the machine and in the manuals indicates a potentially hazardous situation which, if not avoided, could result in death or serious injury.



The signal word **CAUTION** on the machine and in the manuals indicates a potentially hazardous situation which, if not avoided, may result in minor or moderate injury. It may also be used to alert against unsafe practices.



The signal word **IMPORTANT** identifies procedures which must be followed to avoid damage to the machine.

Safe Operation Needs a Qualified Operator



AVOID SERIOUS INJURY OR DEATH
Operators must receive instructions before operating the machine. Untrained operators can cause serious injury or death. For an operator to be qualified, he or she must not use drugs or alcoholic drinks which impair alertness or coordination while working. An operator who is taking prescription drugs must get medical advice to determine if he or she can safely operate a machine and the equipment.

Operator Training

- Check the rules and regulations at your location. The rules may include an employer's work safety requirements. Regulations may apply to local driving requirements or use of a Slow Moving Vehicle (SMV) emblem. Regulations may identify a hazard such as a utility line.
- The new operator must start in an area without bystanders and use all the controls until he or she can operate the machine safely under all conditions of the work area.

2. Safety

2.1 General Safety Information

Importance of Safety

Operating Safety

- Read and follow instructions in this manual and the machine's Operator's Manual before operating.
- Give operating instructions to the operators before allowing them to operate the machine.
- This equipment is dangerous to persons unfamiliar with its operation.
- Check for overhead and / or underground lines before operating equipment (if applicable).
- In addition to the design and configuration of equipment, hazard control and accident prevention are dependent upon the awareness, concern, prudence and proper training of personnel involved in the operation, transport, maintenance and storage of equipment.
- Check that the attachment is securely fastened to the machine.
- Make sure all the machine controls are in NEUTRAL before starting the machine.
- Operate the equipment only from the operator's position.
- Operate the equipment according to the Operator's Manual.
- When learning to operate the equipment, do it at a slow rate in an area clear of bystanders.
- DO NOT permit personnel to be in the work area when operating the equipment.
- The equipment must be used ONLY on approved machines.
- DO NOT modify the equipment in any way. Unauthorized modification may impair the function and / or safety and could affect the life of the equipment.
- DO NOT make any adjustments or repairs on the equipment while the machine is running.
- Keep shields and guards in place. Replace if damaged.
- DO NOT operate equipment in poor visibility conditions such as fog, darkness, or any conditions that limit clear visibility less than 300 feet (100 m) in front of and to the sides of the equipment.
- DO NOT operate in a work area that has not been inspected for foreign debris and obstacles.
- Remove any foreign objects and clearly mark any objects that cannot be removed.
- Wear safety glasses, gloves, hearing protection and other protective clothing when required.
- Do not allow persons under the influence of alcohol, medications, or other drugs that can impair judgment to operate or maintain the machine.
- Before you service the Land Grader, remove the key from the machine and place a Do Not Operate tag on the machine or remove the Land Grader from the machine.
- Do not wear loose hanging clothing. These precautions will help prevent you from becoming caught in the moving parts or on levers and latches on the machine.
- Use care when climbing on frame to prevent slipping or falling.

2. Safety

2.1 General Safety Information

Importance of Safety (Cont'd)

Fire Prevention Safety

- Flammable debris (leaves, grass, etc.) must be removed regularly. If flammable debris is allowed to accumulate, it can cause a fire hazard. Clean often to avoid this accumulation.
- The equipment's hydraulic motor compartment must be inspected every day and cleaned if necessary to prevent fire hazards and overheating.
- All fuels, most lubricants and some coolant mixtures are flammable. Flammable fluids that are leaking or spilled onto hot surfaces or onto electrical components can cause a fire.

Transporting Safety

- Comply with state and local laws governing highway safety and movement of machinery on public roads.
- Check local laws for all highway lighting and marking requirements.
- Never allow riders on either machine or equipment.
- If transporting the attachment on a truck or trailer, make sure it is properly secured to the transport vehicle.

Hydraulic System

- Check hydraulic tubes, hoses and fittings for damage and leakage. Never use open flame or bare skin to check for leaks. Hydraulic tubes and hoses must be properly routed and have adequate support and secure clamps. Tighten or replace any parts that show leakage.
- Always clean fluid spills. Do not use gasoline or diesel fuel for cleaning parts. Use commercial nonflammable solvents.

!**WARNING**!



Leaking fluids under pressure can enter the skin and cause serious injury or death. Immediate medical attention is required. Wear goggles. Use cardboard to check for leaks.

Laser Radiation

!**WARNING**!

LASER RADIATION

Avoid direct eye exposure. CLASS 3A / 3R Laser Product.

Failure to comply with the following messages could result in death or serious injury.

- Use of laser products by people other than those trained on laser products may result in exposure to hazardous laser light.
- NEVER look into the laser beam or direct it to the eyes of other people.
- Always operate the laser unit in a way that prevents the beam from getting into people's eyes.

3. Inspection and Setup

3.1 General Information

Pre-Operation Inspection

Before operating the Land Grader for the first time and each time thereafter, use the following list as a guideline during equipment inspection.



WARNING



AVOID SERIOUS INJURY OR DEATH

- Disengage machine's auxiliary hydraulics, engage the machine's parking brake, stop the engine and make sure all rotating components are completely stopped before connecting, disconnecting, adjusting or cleaning equipment.
- Always keep shields and all guards in place when using the equipment.
- Disengage machine's auxiliary hydraulics for road travel.
- Keep hands, feet and clothing away from rotating parts.

- Lubricate the attachment per the schedule outlined in the Maintenance Section. See "Service Schedule".
- Inspect the Land Grader mounts, mounting flange and all welds on the Land Grader mounting frame for wear or damage each time the Land Grader is removed from the machine.
- Check that all shields and guards are in place.
- Check all welds on the attachment for wear and damage each time the attachment is removed from the machine.
- Check for damaged or missing safety decals. Replace if necessary.

- Inspect the machine's mounting frame. (See the machine's Operator's Manual for inspecting the mounting frame). Replace any parts that are damaged, bent or missing. Keep all fasteners tight. Look for cracked welds.



WARNING



Leaking fluids under pressure can enter the skin and cause serious injury or death. Immediate medical attention is required. Wear goggles. Use cardboard to check for leaks.

- Check condition of all hydraulic components for leaks. Repair as required.

NOTE: Do not operate with hydraulic leaks.

- Verify that the Land Grader is properly connected to the machine.

3. Inspection and Setup

3.2 Inspection

Daily Inspection

NOTE: Inspect the attachment by performing a walk around daily before and after use. Use the following inspection checklist as a guideline.

Check the following items every 10 hours of operation:

- Verify that the Land Grader is properly connected to the machine.
- Check that all shields and guards are in place.
- Check hydraulic lines, connections and fittings for hydraulic oil leaks. Repair or replace damaged parts if necessary.
- Check the Land Grader mounting hardware for wear or damage. Inspect the pins and mount (on the attachment) for wear or damage. Repair or replace damaged parts if necessary.

Weekly Inspection

Check the following items every 40 hours of operation:

- Check all bolts for tightness.
- Check hydraulic tubes, hoses and fittings for wear, damage and leakage.
- Inspect the frame for cracks, bends, or damage.
- Check for damaged or missing decals. Replace if necessary.
- Lubricate as required.
- Check that all bolts are tight.

Drive the machine to the Land Grader and align the machine to the frame for connection. Stop the engine, exit the machine, and secure the Land Grader mounting frame to the machine.

Land Grader Mounting Frame

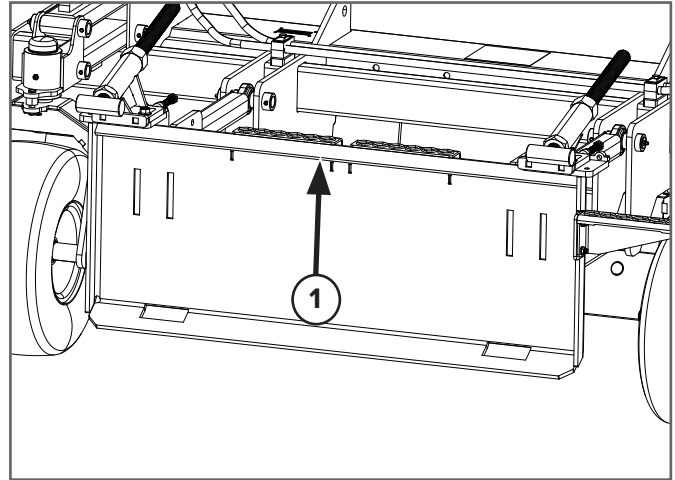

Figure 1

Inspect the Land Grader mounting flange (Item 1) [Figure 1] and all welds on the Land Grader mounting frame for wear or damage each time the Land Grader is removed from the machine.



WARNING



AVOID SERIOUS INJURY OR DEATH

Before servicing the attachment:

- **Always park on a flat level surface.**
- **Lower lift arms and place attachment flat on the ground.**
- **Place all controls in NEUTRAL.**
- **Engage the parking brake.**
- **Wait for all moving parts to stop.**
- **Stop the engine and remove the key.**

SEE MACHINE'S OPERATOR'S MANUAL FOR ADDITIONAL INFORMATION.

3. Inspection and Setup

3.3 Setup

Receiver Mast Installation

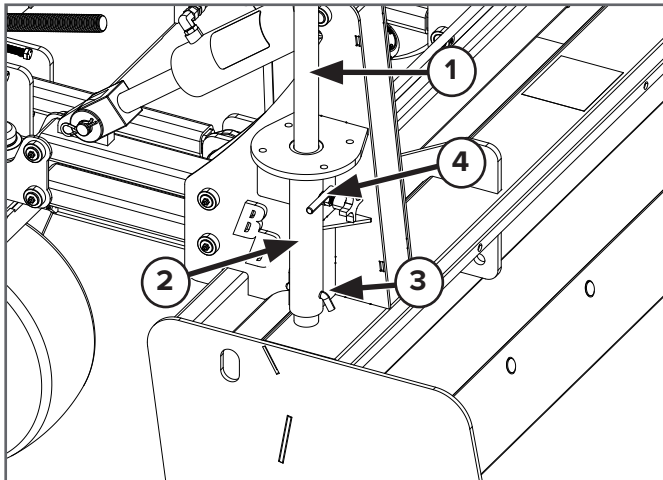

Figure 2

Install the receiver mast (Item 1) [Figure 2] into the mount (Item 2).

Hold the receiver mast flush with the bottom of the mount.

Install the pin (Item 3) and tighten the bolt (Item 4) [Figure 2] securely against the receiver mast to prevent movement during operation.

Repeat procedure on opposite side of Grader.

Laser Receiver Installation

Note: The laser receiver installation in this section is general information. See the Laser Receiver User Guide for additional installation and adjustment information.

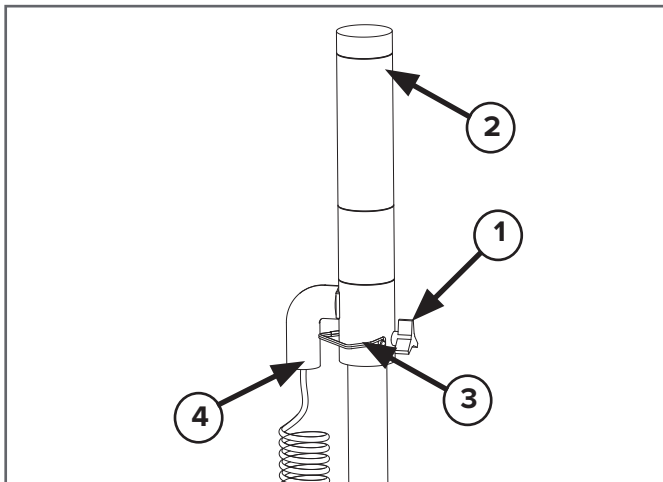

Figure 3

Loosen the knobs (Item 1) [Figure 3] on the Laser Receiver (Item 2).

Slide the Laser Receiver onto the receiver mast and align the holes for the pin (Item 3) [Figure 3].

Install the pin (Item 3) [Figure 3] and fasten the snap lock to the pin.

Tighten the two knobs (Item 1) [Figure 3].

Connect the laser receiver harness (Item 4) [Figure 3] to the laser receiver. Connect the other end of the harness to the receiver junction box.

Repeat procedure on opposite side of Grader.

Controller Installation

Note: The controller installation in this section is general information. See the Controller User Guide for additional installation and adjustment information. Install the controller with the control panel facing the operator.

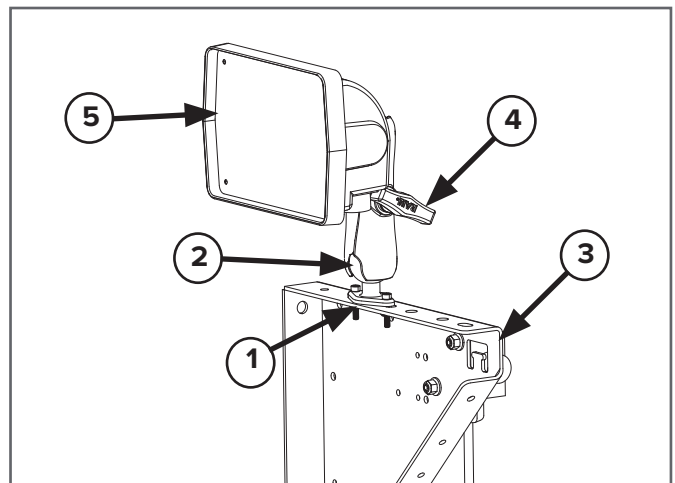

Figure 4

Use the standard hardware (Item 1) [Figure 4] to install the ball mount (Item 2) to the controller bracket (Item 3) on the Land Grader.

Loosen the knob (Item 4) [Figure 4] and slide the Laser Controller (Item 5) on the ball mount (Item 2).

3. Inspection and Setup

3.3 Setup (Con't)

Controller Installation (Con't)

Adjust the controller position and tighten the knob (Item 4) [Figure 4] securely against the mount.

Connect the remaining harnesses to the back of the controller. The connectors are keyed so that there is only one way to connect each harness.

3.4 Installation With Skid-Steer Loader

Installing The Land Grader

NOTE: Refer to your machine's Operation Manual for information on properly operating and installing attachments to your machine.

NOTE: Verify your machine's load capacity and that your machine is capable of operating the Land Grader.

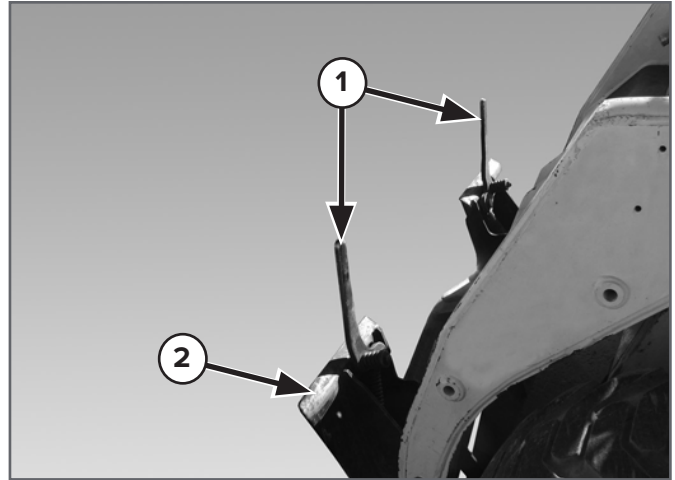

Figure 5

Before connecting to the attachment, inspect the machine's mounting plate. (See the machine's Operator's Manual for inspecting the mounting frame).

Confirm the wedge mount pins (Item 1) [Figure 5] are up until the levers are fully raised.

NOTE: Wedge mount pins may be manual or hydraulic. See your machine's Operation Manual for wedge mount pin operation.

Enter the machine, fasten seat belt, start engine and release the parking brake.

Lower the machine's lift arms and tilt the mounting frame (Item 2) [Figure 5] slightly forward.

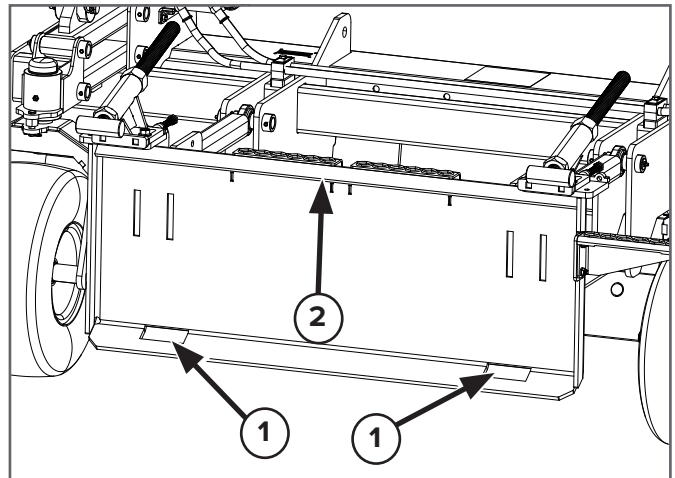

Figure 6



WARNING



CRUSH HAZARD

- Before moving the machine, look in all directions and make sure no bystanders, especially small children are in the work area. Do not allow anyone between the machine and attachment when approaching the attachment for connecting.
- Keep fingers and hands out of pinch points when connecting and disconnecting attachment.

3. Inspection and Setup

3.4 Installation With Skid-Steer Loader (Con't)

Installing The Land Grader (Con't)

Drive the machine forward until the top edge of the machine's mounting frame is under the Land Grader mounting flange (Item 2) [Figure 6]. Raise and tilt the machine's mounting frame back until the frame makes contact with the machine.

Engage parking brake, shut engine off, remove seat belt and exit the machine.

Push the wedge mount levers (Item 1) [Figure 5] down until the levers are fully engaged in the locked position in the slots (Item 1) [Figure 6].

 **WARNING** 

AVOID SERIOUS INJURY OR DEATH

The locking pins / wedges must extend through the holes in the attachment mounting frame. Failure to secure locking pins / wedges can allow attachment to come off.

SEE MACHINE'S OPERATOR'S MANUAL FOR ADDITIONAL INFORMATION.

Roll-Back Stop Adjustment



Figure 7

Position the Land Grader and machine on level area that is on grade. See image in [Figure 7].

Lower the cutting blade(s) on grade.

Engage parking brake, shut engine off, remove seat belt and exit the machine.

NOTE: Make sure the dozer blade is level before adjusting tilt stops.

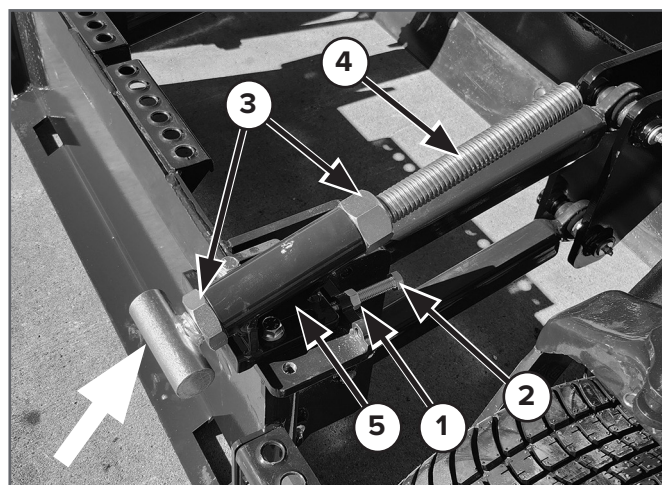

Figure 8

There are two ways to make this adjustment:

Loosen the two jam nuts (Item 1), then loosen the two bolts (Item 2).

Adjust the tilt stop (Item 5) until the adjustment rod (Item 4) is against the lift arm of the machine [Figure 8].

Or-

Loosen the two jam nuts (Item 3) and position the adjustment rod (Item 4) until it is against the lift arm of the machine.

Secure the two jam nuts (Item 3) on the adjustment rod (Item 4) [Figure 8].

Repeat the procedure for the other tilt stop making sure both sides are adjusted evenly.

3. Inspection and Setup

3.4 Installation With Skid-Steer Loader (Con't)

Skid Plate Adjustment

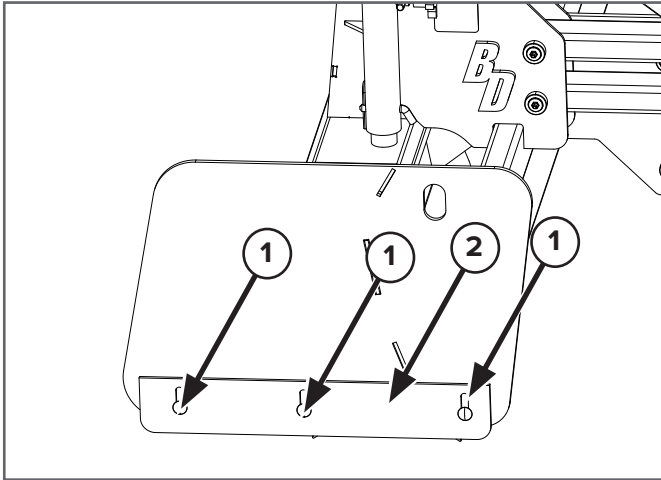

Figure 9

Position the Land Grader and machine on level area that is on grade.

Loosen the bolts (Item 1) [Figure 9], raise or lower the skid plate (Item 2) until parallel with the ground.

Connecting Hydraulic Hoses

! **IMPORTANT** !

Thoroughly clean the quick couplers before making connections. Dirt can damage the hydraulic system.

Remove dirt or debris from the male and female couplers.

Visually inspect the couplers for corroding, cracking, damage, or excessive wear.

Connect the attachment hydraulic hoses to the machine. Pull on each hose to verify full connection is made.

NOTE: Make sure the quick couplers are fully engaged. If the quick couplers do not fully engage, check to see that the couplers are the same size and type.

Electrical Harness Installation

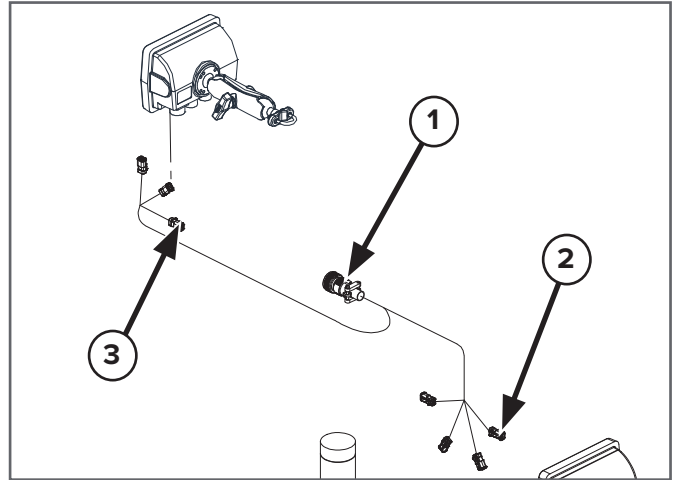

Figure 10

Connect the solenoid connectors (Item 2) [Figure 10] to the valve block solenoids.

Connect the control box connectors (Item 3) [Figure 10] to the control box.

Connect the machine 14-pin connector (Item 1) [Figure 10] to the electrical connection on the host machine.

Refer to the Electrical Specifications on pages 39-40 for pin out identification.

4. Operation

4.1 Land Grader Operation

Entering the Operator's Position

 **IMPORTANT** 



SEE MACHINE'S OPERATOR'S MANUAL FOR DETAILED INFORMATION ON OPERATING THE LOADER.

Use the attachment safety treads, handles and steps (on the machine) to enter the operator's position. When in the operator's position, lower safety seat bar, fasten the seat belt, start the engine and release the parking brake.

Leaving the Operator's Position

Park the machine / attachment on a flat level surface. Place all controls in neutral, engage the parking brake and stop the engine. Leave the operator's position.

 **WARNING** 

AVOID SERIOUS INJURY OR DEATH

Before servicing the attachment:

- **Always park on a flat level surface.**
- **Lower lift arms and place attachment flat on the ground.**
- **Place all controls in NEUTRAL.**
- **Engage the parking brake.**
- **Wait for all moving parts to stop.**
- **Stop the engine and remove the key.**

SEE MACHINE'S OPERATOR'S MANUAL FOR ADDITIONAL INFORMATION.

 **WARNING** 

AVOID SERIOUS INJURY OR DEATH

Never use the attachment wheels as a step while entering and exiting the machine.



Operating The Land Grader (w/o Laser)

Enter the machine.

Fasten seat belt, start the engine, and release the parking brake.

While moving forward / backward, position the dozer cutting blade for desired grade.

Operating The Land Grader (with Laser)

 **WARNING** 

LASER RADIATION

Avoid direct eye exposure. CLASS 3A / 3R Laser Product.

Enter the machine.

Fasten seat belt, start the engine, and release the parking brake.

4. Operation

4.1 Land Grader Operation (Con't)

NOTE: The following picture shows a skid-steer loader but the setup process is similar for other approved machines.



Figure 11

Operating The Land Grader (with Laser) (Con't)

Make sure the dozer blade is level.

NOTE: Laser receivers must be located above the cab and must be at the same height.

Lower the cutting blade(s) on grade.

NOTE: Refer to the “Controller Settings - 123500 section.



WARNING



AVOID EYE INJURY

Never look directly into the laser beam. Set the laser at a height that prevents the beam from shining directly into bystanders' eyes.

General Construction (Flat Grade)

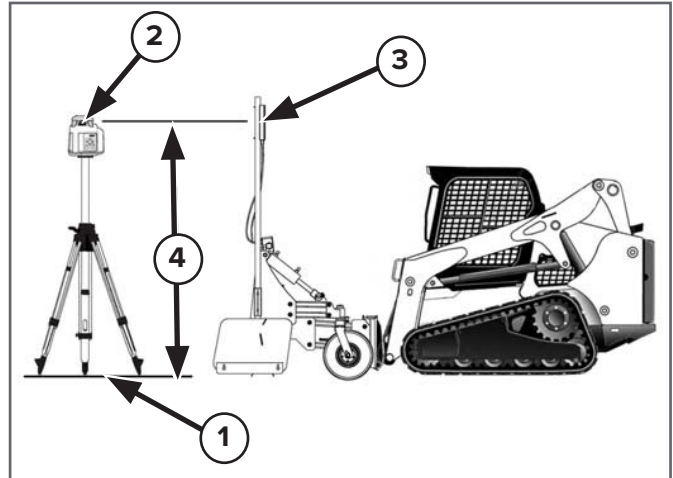

Figure 12

1. Place the laser beacon and tripod on an area that is close to finish grade (Item 1) [Figure 12].
2. Level the tripod.
3. Raise the laser beacon (Item 2) [Figure 12] above the loader cab to align with the laser receivers (Item 3) this will create a benchmark (Item 4) to start from.
4. Secure the laser beacon in position.
5. Make several test passes and check the grade.

NOTE: If grade is too high or too low, adjust the laser beacon down or up. The laser beacon used must have a rotation speed of at least 600 RPM.

4. Operation

4.1 Land Grader Operation (Con't)

Job Site Recommendations

Rough grade the job-site without the laser.

The Land Grader will fill in low spots and carry material to get the surface close to grade. (This will require less material to be moved when using the laser).

Travel at a slow speed when laser dozing.

Throttle should be set at 1/2 speed.

Position laser beacon and receivers above the machine cab.

NOTE: This will allow the operator to flat doze / grade in any direction.

Turn laser to manual when turning machine around.

Enter the machine.

Fasten seat belt, start the engine, and release the parking brake.

The Land Grader is ready to operate.

NOTE: Excessive weight transfer from skid steer to dozer will damage caster wheels. Caster wheels will only support the weight of the dozer itself.



Figure 13



Figure 14

4. Operation

4.1 Land Grader Operation (Con't)

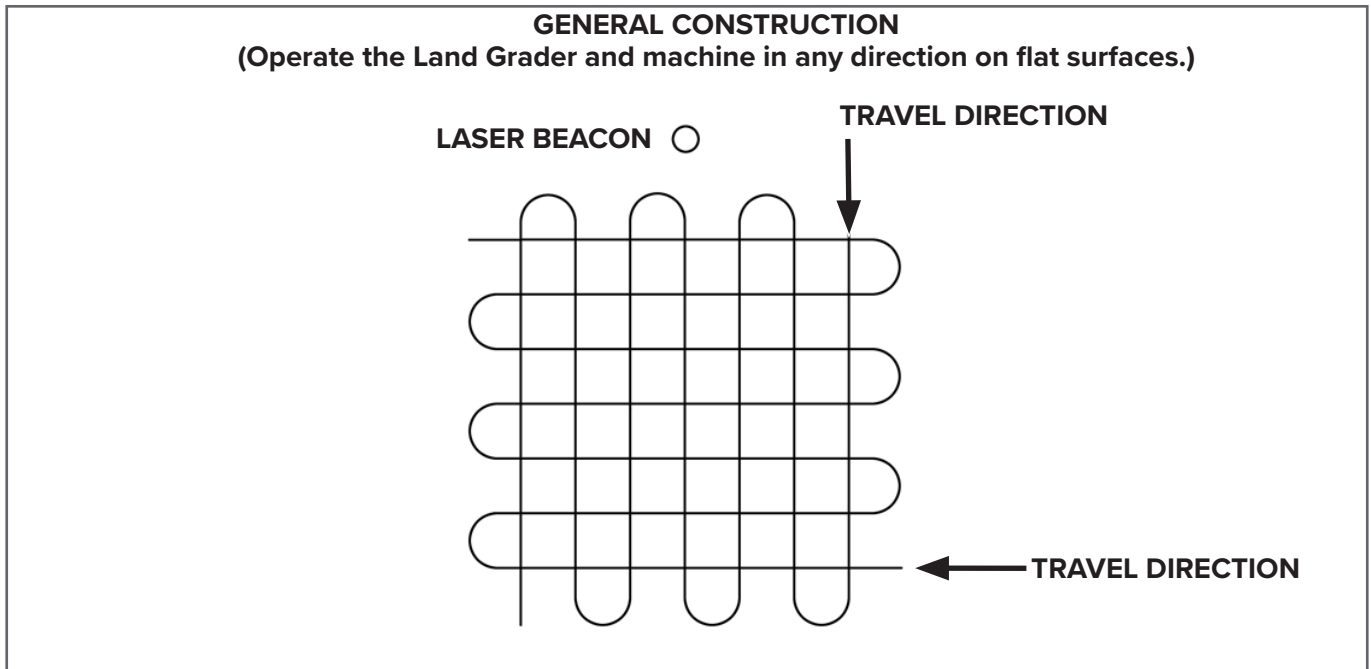

Figure 15

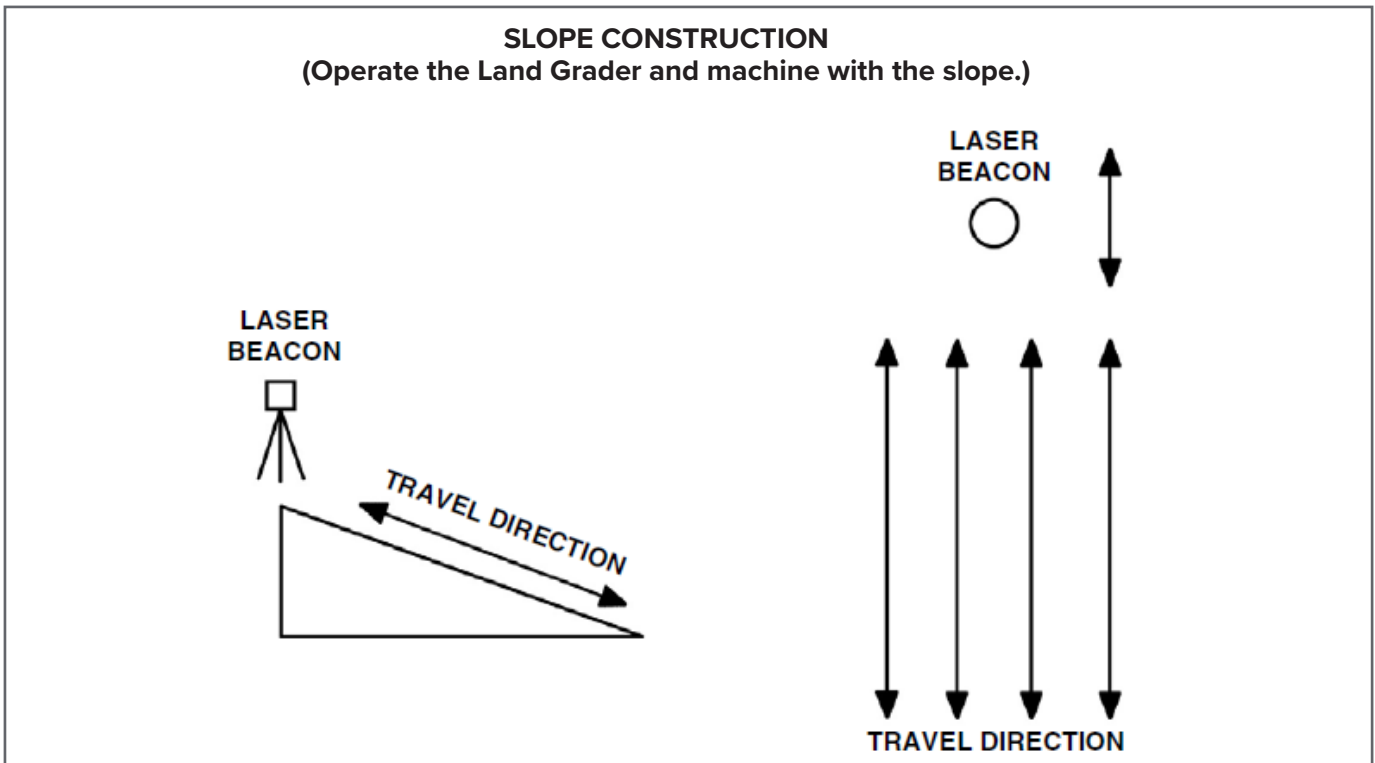
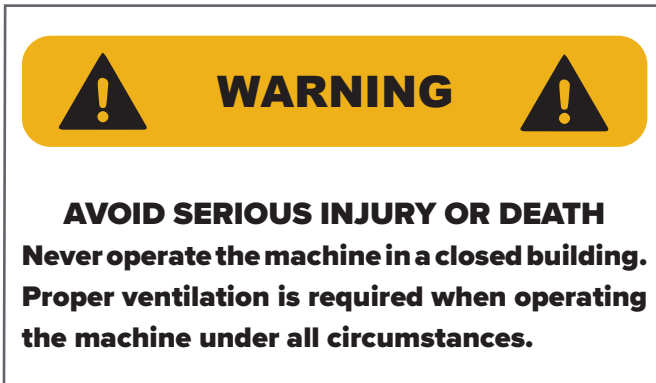

Figure 16

5. Maintenance

5.1 Maintenance Safety

Maintenance Safety



- Always keep the work area clean and dry.
- Always use personal protection devices such as eye, hand and hearing protection when performing any service or maintenance.
- A fire extinguisher and first aid kit should be readily accessible while performing maintenance on this machine.
- Before working or doing maintenance on the Land Grader, apply the parking brake, shut off the engine and remove the key or remove the Land Grader from the machine.
- Never work under machine or equipment unless the machine or equipment is blocked or supported securely.
- Never operate the machine in a closed building.
- Proper ventilation is required under all circumstances.
- Disconnect the battery (both terminals) before welding on any part of the machine. Failure to do so may cause damage to electrical components.
- When working around batteries, remember that all of the exposed metal parts are “live”. Never lay a metal object across the terminals because a spark, short circuit, explosion or personal injury may result.
- Battery posts, terminals and related accessories contain lead and lead compounds. Wash hands

after handling.

- When replacement parts are necessary, genuine factory replacement parts must be used to restore your equipment to original specifications.
- Blue Diamond will not be responsible for injuries or damage caused by use of unapproved parts and / or accessories.
- When completing service or maintenance on this machine, make sure all shields and guards are installed before placing the machine into service.

General Maintenance

To ensure efficient operation, you should inspect, lubricate, and make necessary adjustments and repairs at regular intervals. Keep good maintenance records and adequately clean your machine after each use.

Proper maintenance is important. Follow all maintenance instructions and schedules included in this section.

Inspect the following:

- All components and hardware to ensure equipment is secure and thoroughly tightened.
- Land Grader mounting frame and all welds on the Land Grader for cracks or damage.
- Visually check the hydraulic hoses and quick couplers for corroding, cracking, damage or excessive wear.
- Machine’s decals for damage.

NOTE: Repair or replace any damaged parts.

5. Maintenance

5.2 Maintenance Items

Lubricating The Land Grader

NOTE: Thoroughly wash, clean and dry the Land Grader before servicing or inspection of Land Grader components.



WARNING



AVOID INJURY OR DEATH

Stop the engine and disconnect the auxiliary hydraulic hose quick couplers before performing maintenance on the Land Grader.



WARNING



AVOID INJURY OR DEATH

Wear safety glasses to prevent eye injury when any of the following conditions exist:

- When fluids are under pressure.
- Flying debris or loose material is present.
- Engine is running.
- Tools are being used.

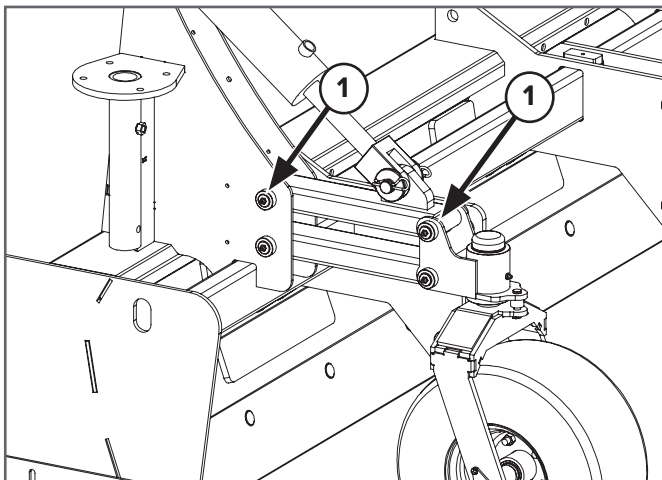

Figure 17

Lubricate the four grease fittings (Item 1) [Figure 17] (4 per side) every eight hours of operation.

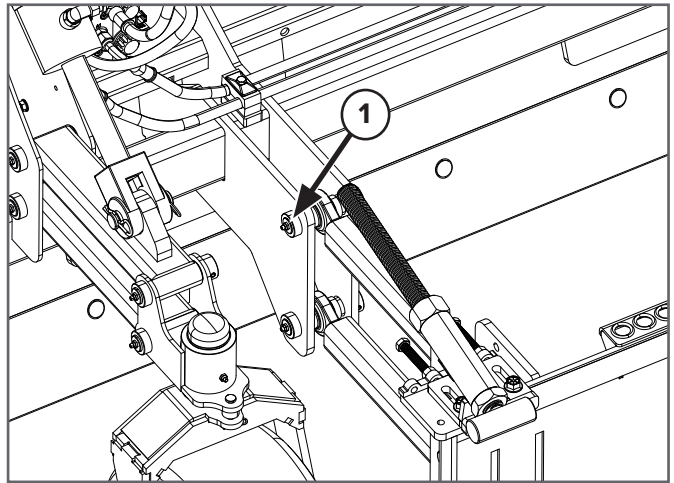

Figure 18

Lubricate the two grease fittings (Item 1) [Figure 18] (2 per side) every eight hours of operation.

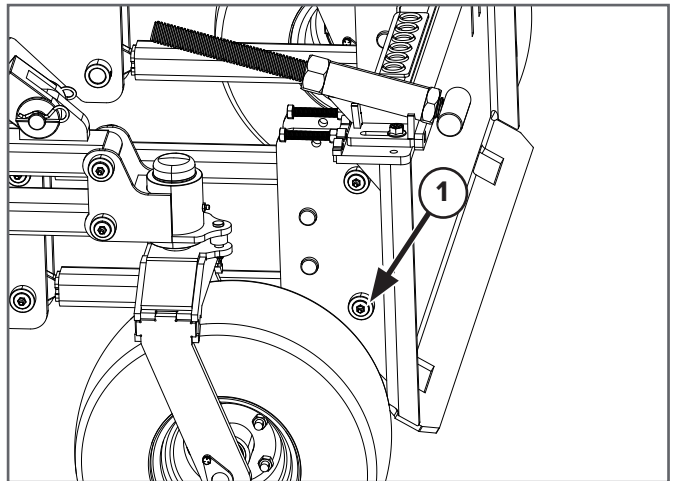

Figure 19

Lubricate the two grease fittings (Item 1) [Figure 19] (2 per side) every eight hours of operation.

5. Maintenance

5.3 Removal And Replacement

Blade Removal

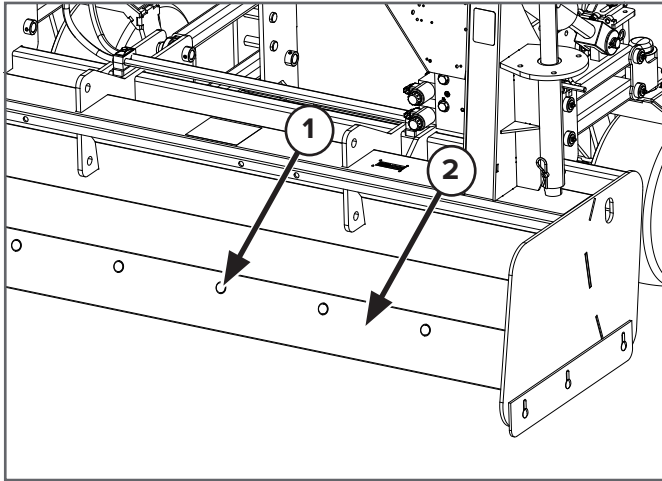

Figure 20

Remove the bolts and nuts (Item 1) [Figure 20] from the front blade (Item 2). Remove and replace the front blade.

Skid Plate Removal

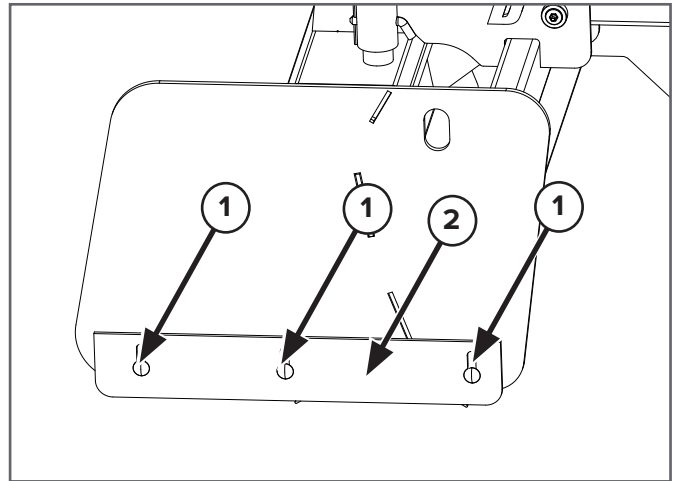

Figure 22

Remove the bolts (Item 1) [Figure 22] and nuts. Remove the skid plate (Item 2) [Figure 22].

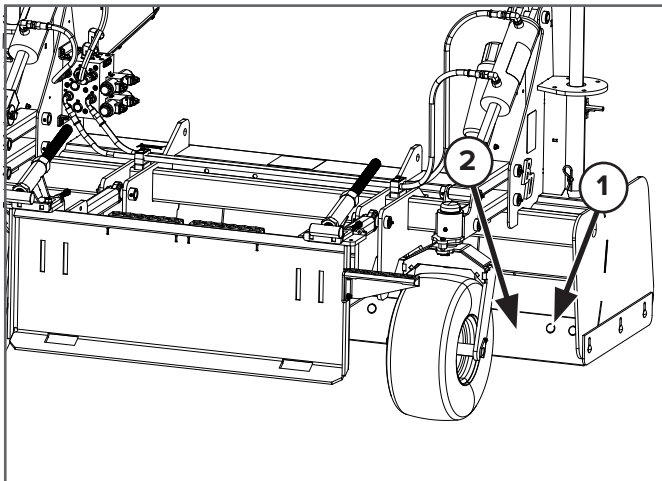

Figure 21

Remove the bolts and nuts (Item 1) [Figure 21] from the rear blade (Item 2). Remove and replace the rear blade.

5. Maintenance

5.4 Storage And Return To Service

Storage

Sometimes it may be necessary to store your Land Grader for an extended period of time. Below is a list of items to perform before storage.

- Make sure the hydraulic hose couplers are capped or plugged.
- Thoroughly wash the attachment before storing it for long periods.
- Lubricate the necessary items.
- Coat the exposed portion of the cylinder rod with grease.
- Check for loose hardware, missing guards, or damaged parts.
- Check for damaged or missing decals. Replace if necessary.
- Replace worn or damaged parts.
- Place the attachment in a dry protected shelter.
- Place the attachment flat on the ground.

NOTE: In muddy conditions or to prevent the attachment from freezing to the ground, put the attachment on planks or blocks before removing the attachment from the machine.

NOTE: Replace or repair any damaged parts, components, decals or reflectors.

Return to Service

After the attachment has been in storage, it is necessary to follow the list of items below to return it to service.

- Lubricate the necessary items.
- Install and operate the attachment and check for correct function.
- Check for leaks. Repair as needed.
- Check the attachment for any damage and repair as required.

6. Parts

6.1 Main Land Grader Parts

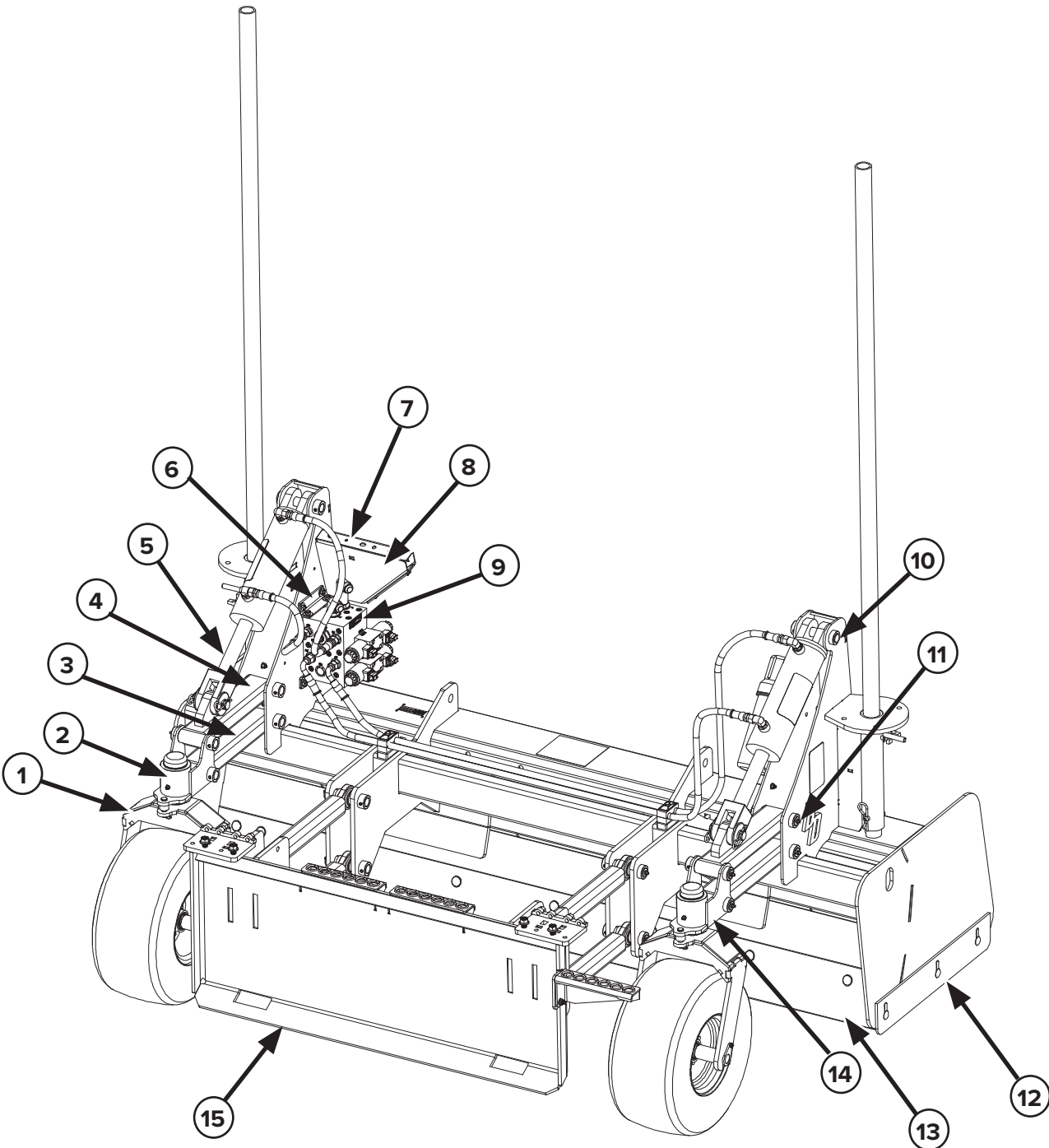

6. Parts

6.1 Main Land Grader Parts

ITEM	PART NUMBER	DESCRIPTION	QTY
1	223308	WHEEL FORK WELDMENT, 11.50"	2
2	223306	WHEEL HUB WELDMENT, LH	1
3	223305	WHEEL LINK BOTTOM WELDMENT	2
4	223304	WHEEL LINK TOP WELDMENT	2
5	223309	CYLINDER, 3-1/2" BORE X 8" STROKE	2
6	223313	BRACKET, VALVE BLOCK	2
7	223311	BRACKET, CONTROL, UNIVERSAL	1
8	223312	COVER, CONTROL, UNIVERSAL	1
9	223337	VALVE BLOCK, PROPORTIONAL	1
10	223316	PIVOT PIN, 1" X 5"	2
11	223317	PIVOT PIN, 1" X 5" WITH GREASE ZERK	8
12	223303	ADJUSTABLE SKID PLATE	2
13	223310	BLADE, 84"	2
14	223307	WHEEL HUB WELDMENT, RH	1
15	223336	SKID STEER QUICKTACH HITCH KIT	1

6. Parts

6.2 Main Land Grader Parts - 2

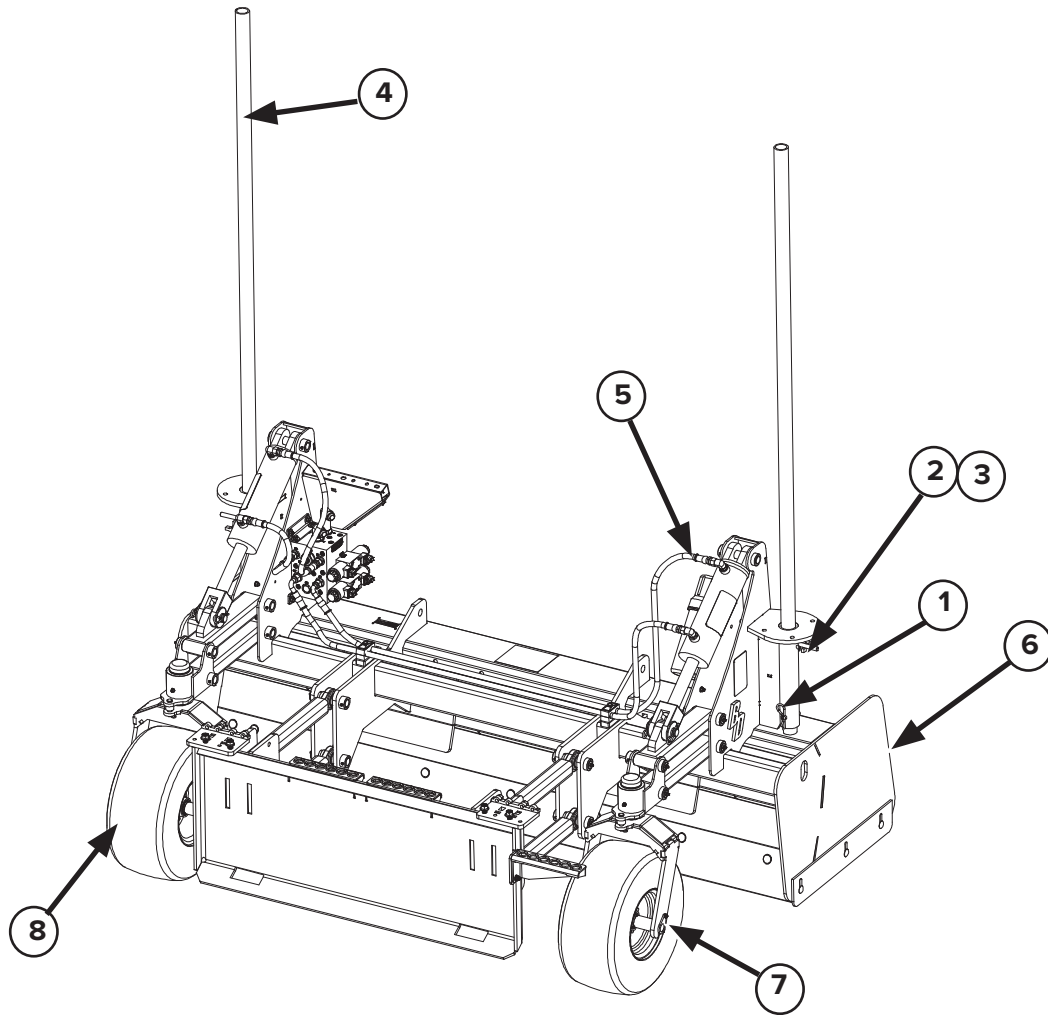

ITEM	PART NUMBER	DESCRIPTION	QTY
1	223300	PIN ASSEMBLY	2
2	223301	PIPE KNOB, ZINC	2
3	223302	PIPE LOCK, ZINC	2
4	223314	MAST PIPE, 1.75 OD	2
5	223332	COMPLETE GRADER HOSE KIT	1
6	223335	GRADER WELDMENT, 84"	1
7	223322	WHEEL AXLE WELDMENT, 12.81"	2
8	223329	TIRE & RIM ASSEMBLY	2

6. Parts

6.3 Blade Assembly Parts

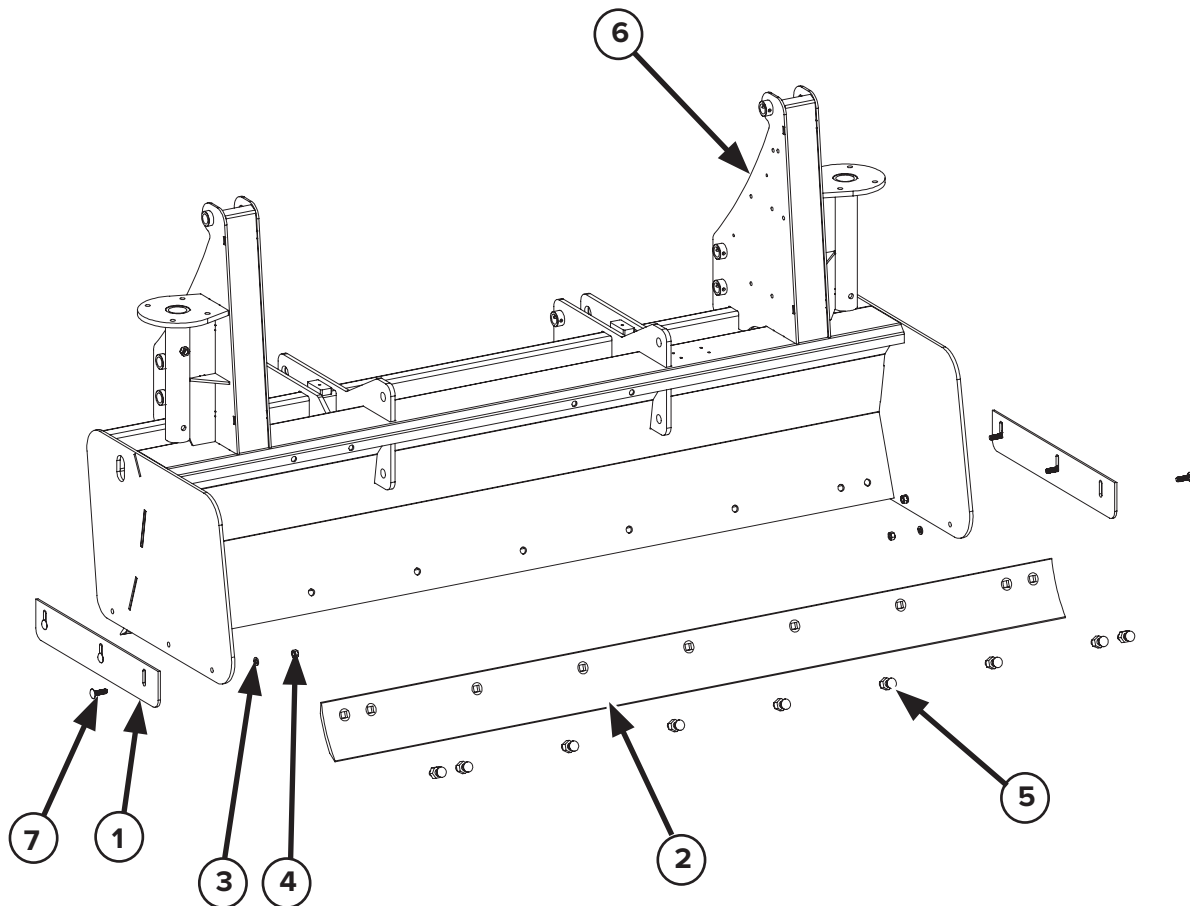

ITEM	PART NUMBER	DESCRIPTION	QTY
1	223303	ADJUSTABLE SKID PLATE	2
2	223310	BLADE, 84"	2
3	299835	LOCKWASHER, 7/16" HELICAL SPRING, ZINC	6
4	299573	NUT, 7/16"-14 UNC, HEX STEEL, ZINC	6
5	223354	BOLT & HEX NUT, 5/8"-11 UNC x 2, GRADER BLADE	18
6	223335	GRADER WELDMENT, 84"	1
7	299409	CARRIAGE BOLT, 7/16"-14 X 1-1/2 ZINC	6

6. Parts

6.4 Quicktach & Tilt Stop Parts

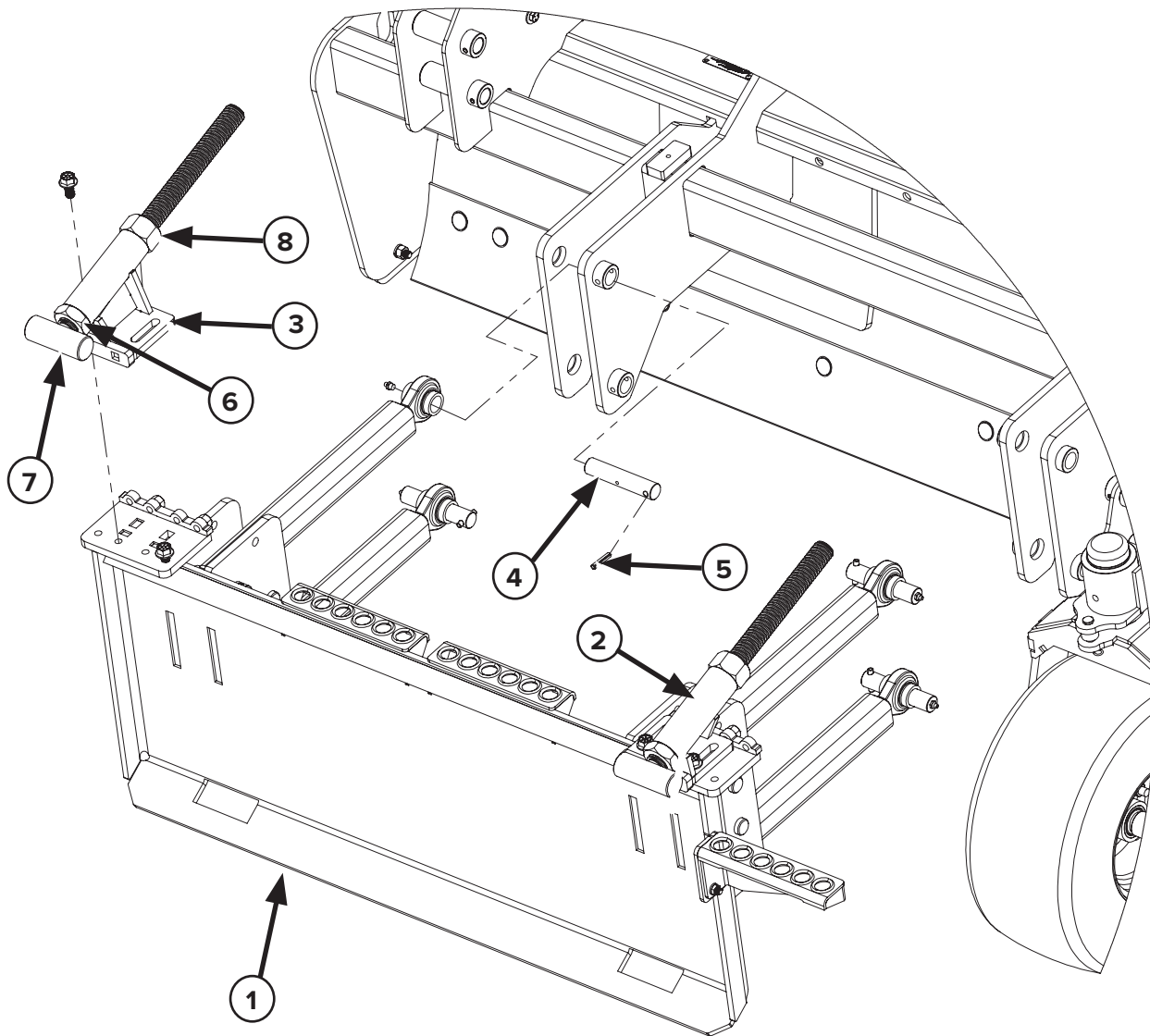

ITEM	PART NUMBER	DESCRIPTION	QTY
1	223336	SKID STEER QUICKTACH HITCH KIT	1
2	223416	BASE WELDMENT, TILT STOP, OFFEST RIGHT	1
3	223417	BASE WELDMENT, TILT STOP, OFFSET LEFT	1
4	223368	CLEVIS PIN	4
5	299902	ROLL PIN	4
6	299681	NUT, 1-1/4-5 ACME, HEX, JAM, ZINC	2
7	223415	STOP WELDMENT, THREADED	2
8	299680	NUT, 1-1/4-5 ACME, HEX, ZINC	2

6. Parts

6.5 Mount Parts

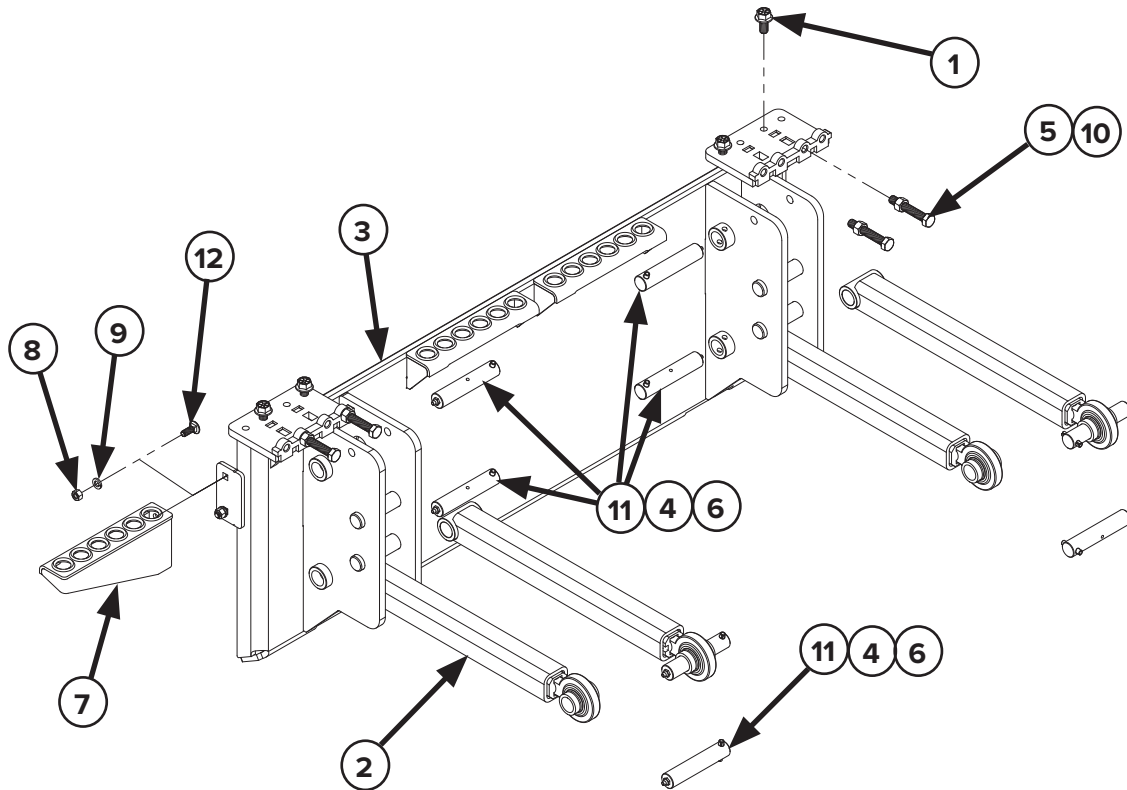

ITEM	PART NUMBER	DESCRIPTION	QTY
1	299404	HEX FLANGE HEAD BOLT, 1/2-13 X 1, ZINC	4
2	223412	Q-TACH LINK WELDMENT	4
3	223413	Q-TACH MOUNT WELDMENT	1
4	299902	ROLL PIN, 5/16 X 1-1/2	8
5	299435	BOLT, 1/2-13 X 3 FULLY THREADED ZINC	4
6	299016	GREASE ZERK, 1/8-27NPT, STRAIGHT ZINC	8
7	223414	STEP WELDMENT, RH, STRAIGHT	1
8	299572	NUT, 3/8-16UNC HEX, ZINC	2
9	299825	LOCKWASHER, 3/8" HELICAL SPRING, ZINC	2
10	299574	NUT, 1/2-13UNC HEX, STEEL ZINC	4
11	223368	PIVOT PIN W/GREASE ZERK	8
12	299403	CARRIAGE BOLT, 3/8-16 X 1, ZINC	2

6. Parts

6.7 Lift Wheel Linkage Parts

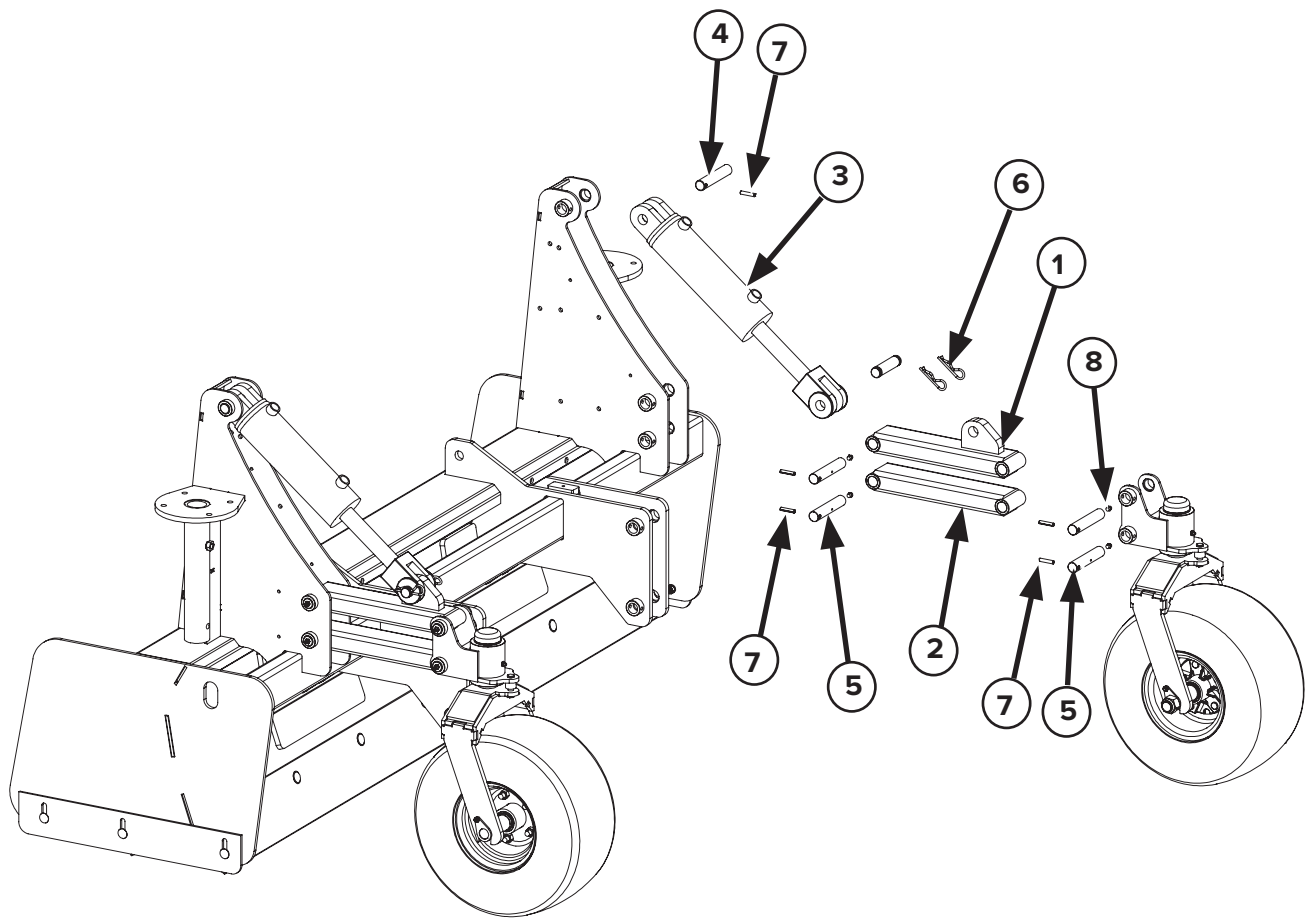

ITEM	PART NUMBER	DESCRIPTION	QTY
1	223304	WHEEL LINK TOP WELDMENT	2
2	223305	WHEEL LINK BOTTOM WELDMENT	2
3	223309	CYLINDER, 3-1/2" BORE X 8" STROKE	2
4	223316	PIVOT PIN, 1" X 5"	2
5	223317	PIVOT PIN, 1" X 5" WITH GREASE ZERK	8
6	201071	HAIR PIN, 9/64" X 2, ZINC	4
7	299902	ROLL PIN, 5/16" X 1-1/2	10
8	299016	STRAIGHT GREASE ZERK, 1/8"-27 NPT, ZINC	8

6. Parts

6.8 Wheel Pivot & Wheel Axle Parts

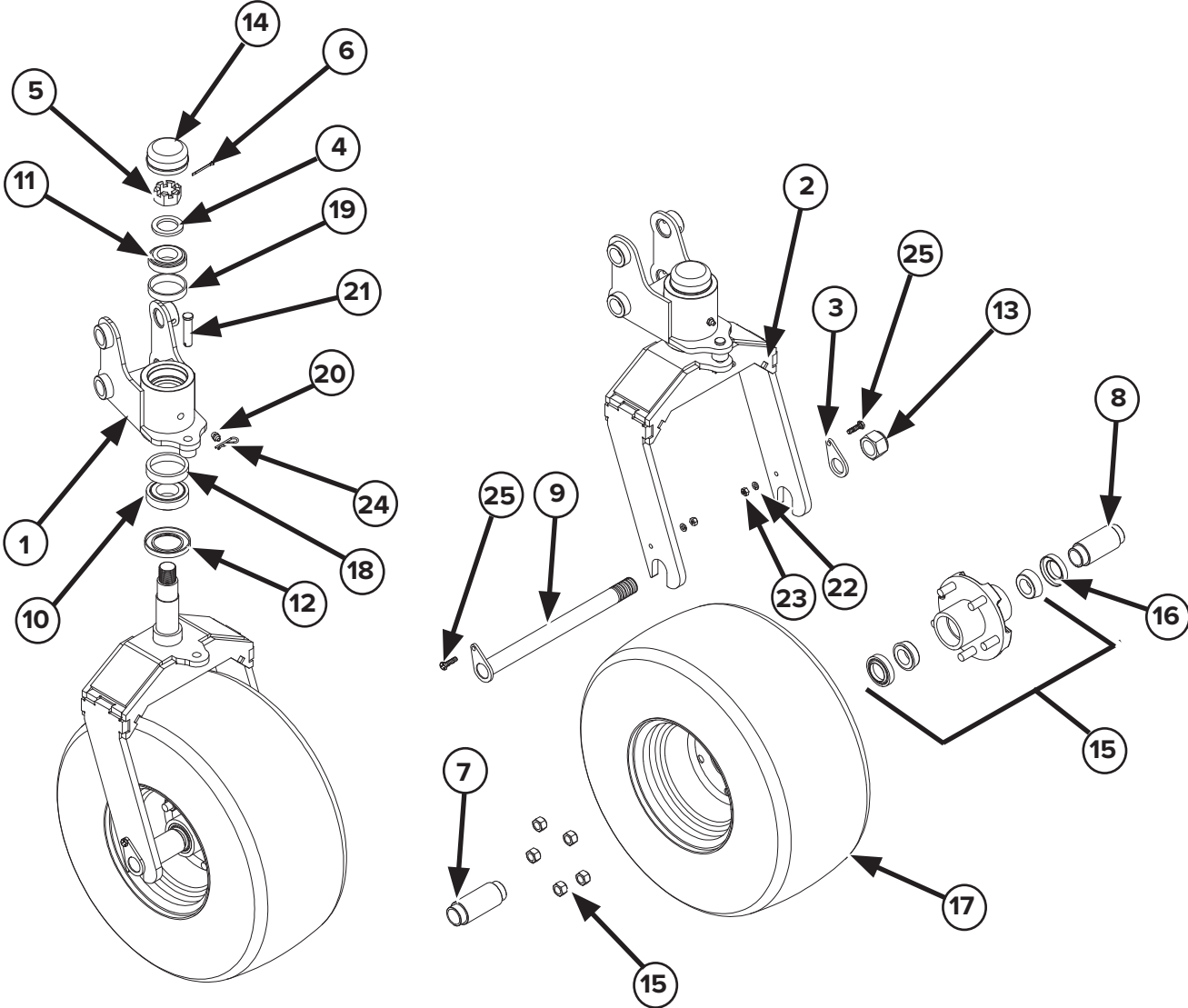

6. Parts

6.8 Wheel Pivot & Wheel Axle Parts

ITEM	PART NUMBER	DESCRIPTION	QTY
1	223306	WHEEL HUB WELDMENT, LH	1
	223307	WHEEL HUB WELDMENT, RH	1
2	223308	WHEEL FORK WELDMENT, 11.50"	1
3	223318	AXLE TAB	1
4	223319	HUB WASHER/SPACER	1
5	299632	CASTLE NUT 1"-14	1
6	204124	COTTER PIN, 1/8" X 2.5"	1
7	223320	LONG WHEEL SPACER, 3.90"	1
8	223321	SHORT WHEEL SPACER, 3.60"	1
9	223322	WHEEL AXLE WELDMENT, 12.81"	1
10	223323	BEARING, LARGE	1
11	223324	BEARING, SMALL	1
12	223325	OIL SEAL, 17443 1.75" X 2.62"	1
13	299633	NUT, 1"-14 NYLOCK	1
14	223326	DUST CAP	1
15	223327	5 BOLT HUB	1
16	223328	OIL SEAL, 1.22" X 1.98"	1
17	223329	TIRE & RIM ASSEMBLY	1
18	223330	RACE, FOR 223323 BEARING	1
19	223331	RACE, FOR 223324 BEARING	1
20	299016	STRAIGHT GREASE ZERK, 1/8"-27 NPT, ZINC	1
21	201075	CLEVIS PIN 1/2" X 2", ZINC	1
22	299810	HELICAL SPRING LOCKWASHER, 1/4", ZINC	2
23	216404	HEX NUT 1/4"-20 UNC ZINC	2
24	223363	HAIR PIN, 3/32" X 1-1/4", ZINC	1
25	299418-1	HEX BOLT, 1/4"-20 X 1", ZINC	2

6. Parts

6.9 Hydraulic Block & Control Box Bracket

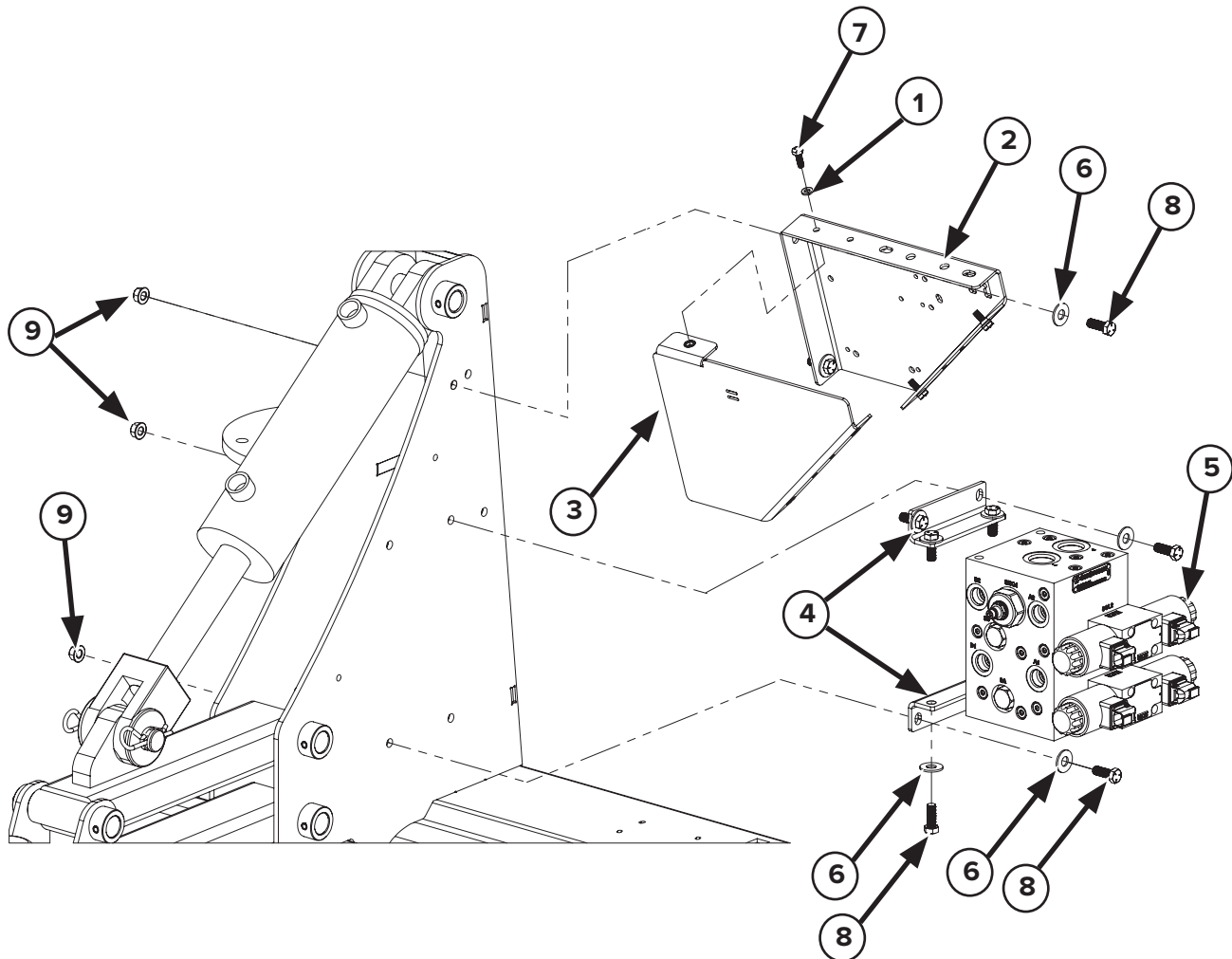

ITEM	PART NUMBER	DESCRIPTION	QTY
1	299810	HELICAL SPRING LOCKWASHER, 1/4", ZINC	3
2	223311	UNIVERSAL CONTROL BRACKET	1
3	223312	UNIVERSAL CONTROL COVER	1
4	223313	VALVE BLOCK BRACKET	2
5	223337	PROPORTIONAL VALVE BLOCK	1
6	299723	FLAT WASHER, 3/8" USS, ZINC	10
7	299413	HEX BOLT, 1/4"-20 X 3/4", ZINC	3
8	299423	HEX BOLT, 3/8"-16 X 1", ZINC	10
9	299562	SERRATED FLANGE NUT, 3/8"-16, ZINC	6

6. Parts

6.10 Hydraulic Valve Assembly

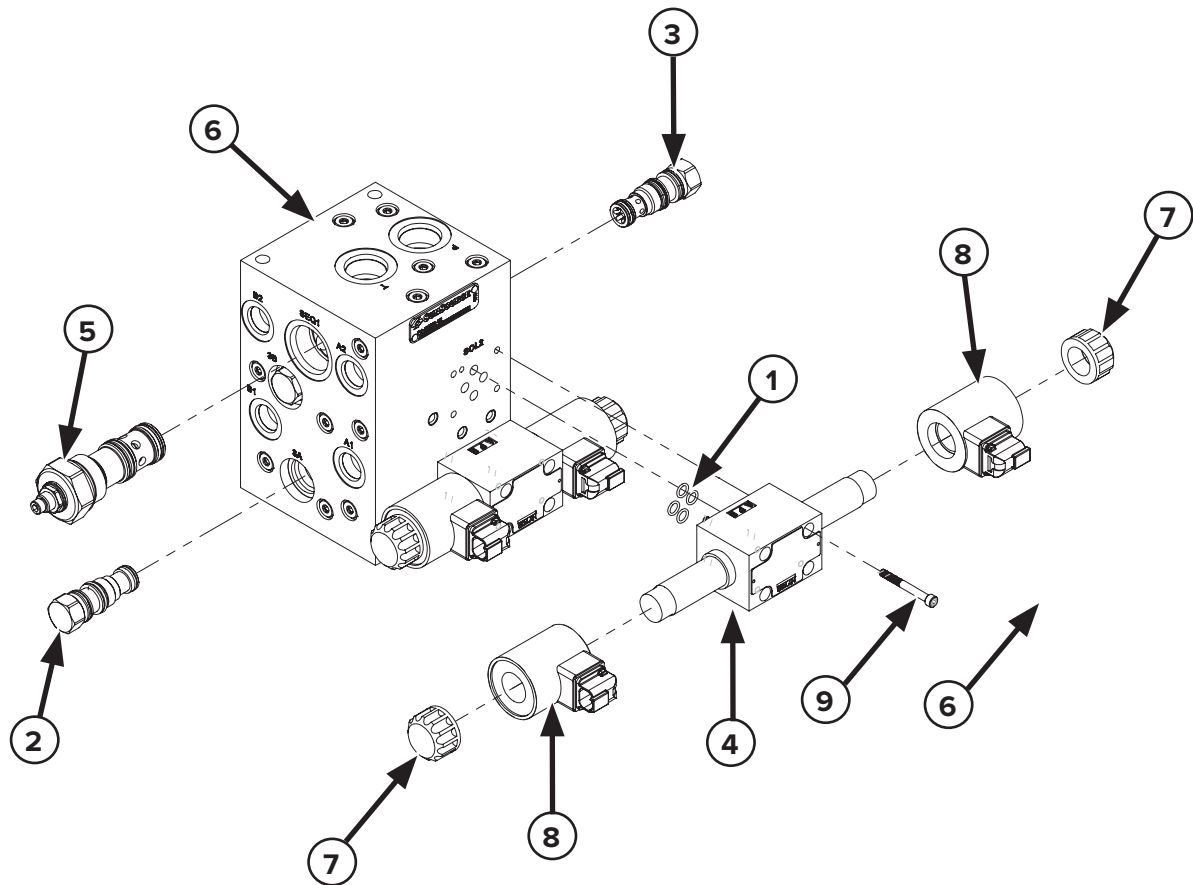

ITEM	PART NUMBER	DESCRIPTION	QTY
1	223384	SEAL KIT, #4 ARGO BODY	2
2	223385	SHUTTLE VALVE (SEAL KIT 223386)	2
3	223387	CHECK VALVE (SEAL KIT 223388)	4
4	223389	PROPORTIONAL VALVE (SEAL KIT 223390)	2
5	223391	SEQUENCE VALVE (SEAL KIT 223392)	1
6	223393	MANIFOLD BODY (SEAL KIT 223394)	1
NS	223395	ORIFICE, 1/16"-27 W .031	1
7	223396	COIL NUT, ARGO	4
8	223397	COIL, 12V, HDD DT04-2P	4
9	299408	SOCKET HEAD CAP SCREW, 10-24 X 1-3/4", PT, ZINC	8

6. Parts

6.11 Hydraulic Hose Kit

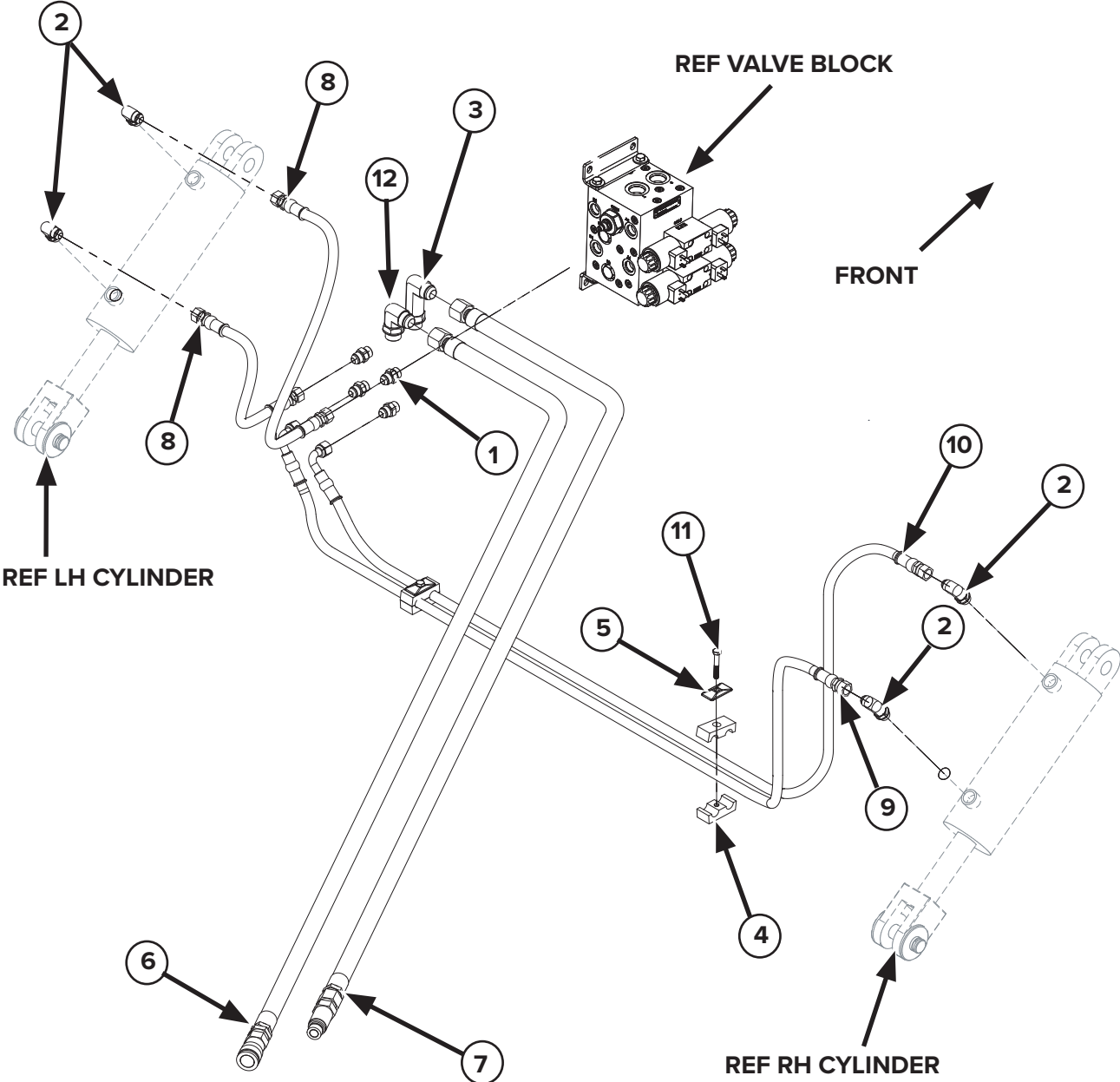

6. Parts

6.11 Hydraulic Hose Kit

ITEM	PART NUMBER	DESCRIPTION	QTY
1	295010-M08JIC-M08ORB	HYD. FITTING 8MB-8MJ	4
2	295030-M08JIC-M08ORB	HYD FITTING, 8MJ-8MB, 90	4
3	295030-M12JIC-M12ORBLL	HYD FITTING, 12MJ X 12MB, 90LL	1
4	223402	PLASTIC BODY CLAMP	2
5	223403	HOSE CLAMP PLATE	2
6	223404	HYD HOSE, 3/4" X 94", 12FJ X 12MB/FEM COUPLER	1
7	223405	HYD HOSE, 3/4" X 94", 12FJ X 12MB/MALE COUPLER	1
8	223406	HYDRAULIC HOSE, 3/8" X 36", 8FJ X 8FJ	2
9	223407	HYDRAULIC HOSE, 3/8" X 86", 8FJ X 8FJX90L	1
10	223408	HYDRAULIC HOSE, 3/8" X 80", 8FJ X 8FJX90L	1
11	299319	HEX BOLT, 5/16"-18 UNC x 2.00", ZINC LK	2
12	295030-M12JIC-M12ORB	HYD FITTING, 12MJ X 12MB, 90°	1

6. Parts

6.12 Hydraulic Schematic

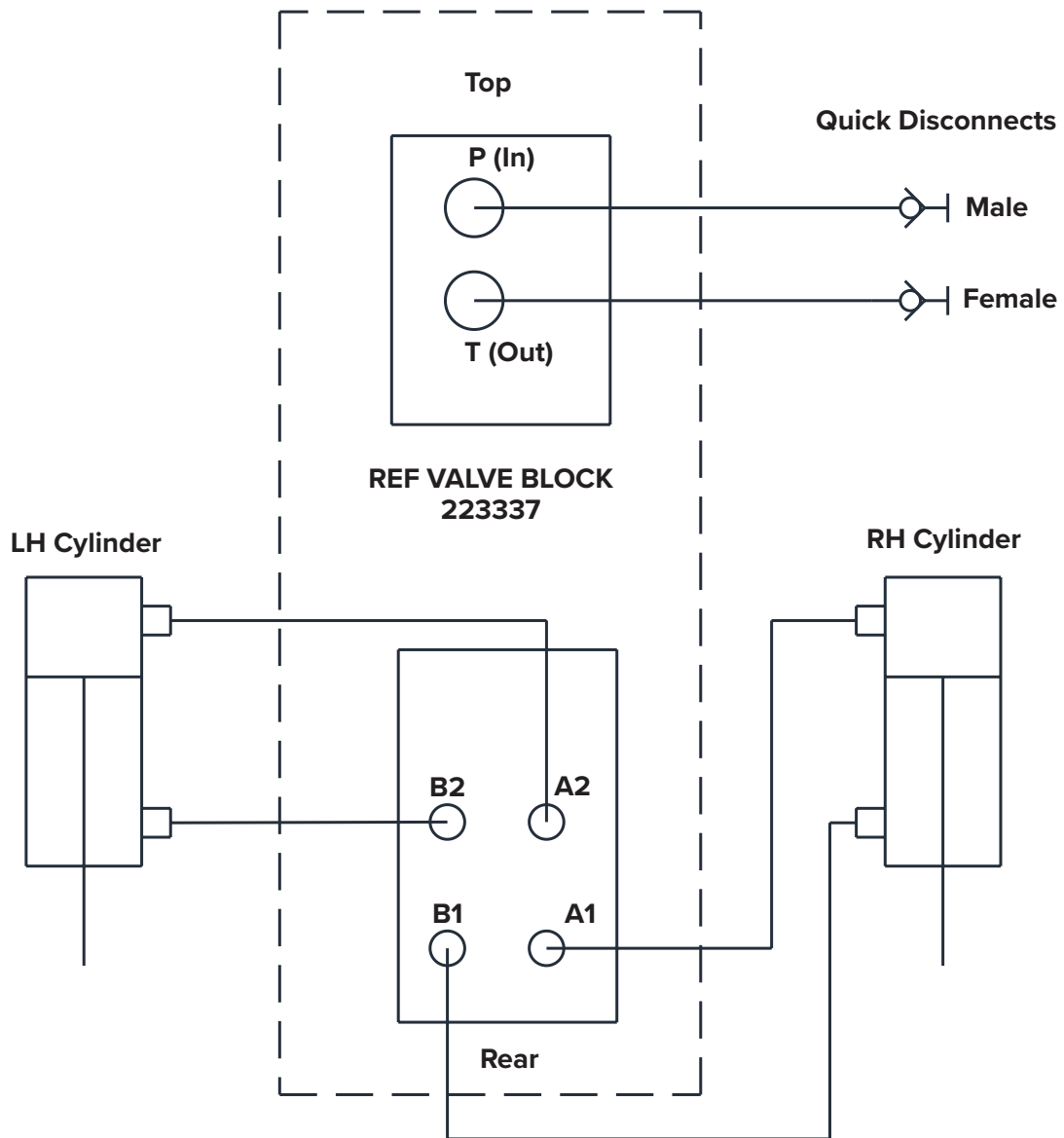

6. Parts

6.13 Masts & Manual Canister Parts

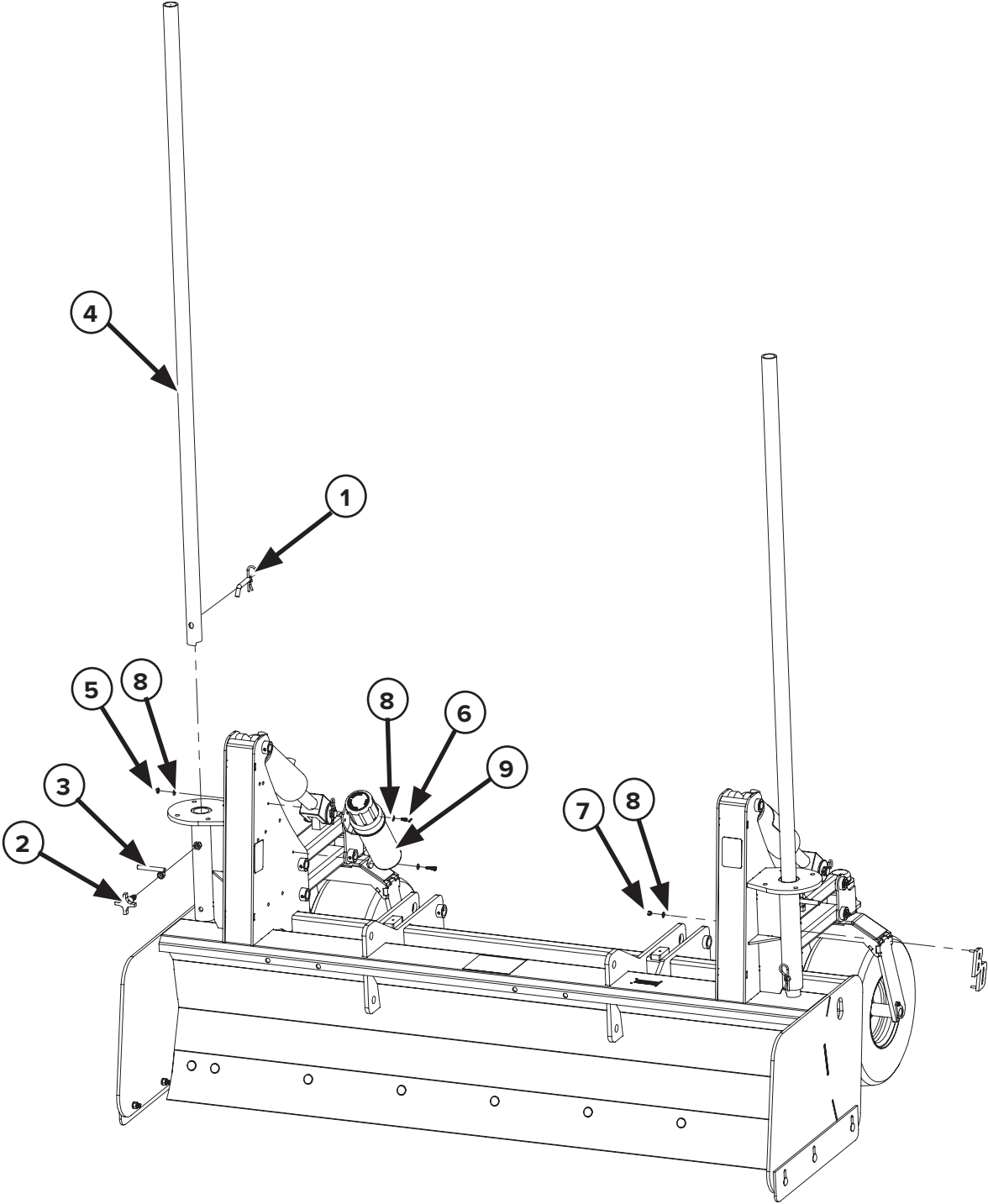

6. Parts

6.13 Masts & Manual Canister Parts

ITEM	PART NUMBER	DESCRIPTION	QTY
1	223300	PIN ASSY	2
2	223301	PIPE KNOB, ZINC	2
3	223302	PIPE LOCK, ZINC	2
4	223314	MAST PIPE, 1.75 OD	2
5	299560	SERRATED FLANGE HEX NUT, 1/4"-20, GR5 ZINC	2
6	299418-1	HEX BOLT, 1/4"-20 X 1, GR5 ZINC	2
7	299615	NYLON-INSERT NUT, 1/4"-20 GR5 ZINC	4
8	216405	FLAT WASHER, 1/4 SAE, ZINC	8
9	216402	MANUAL TUBE	1

6. Parts

6.14 Decals

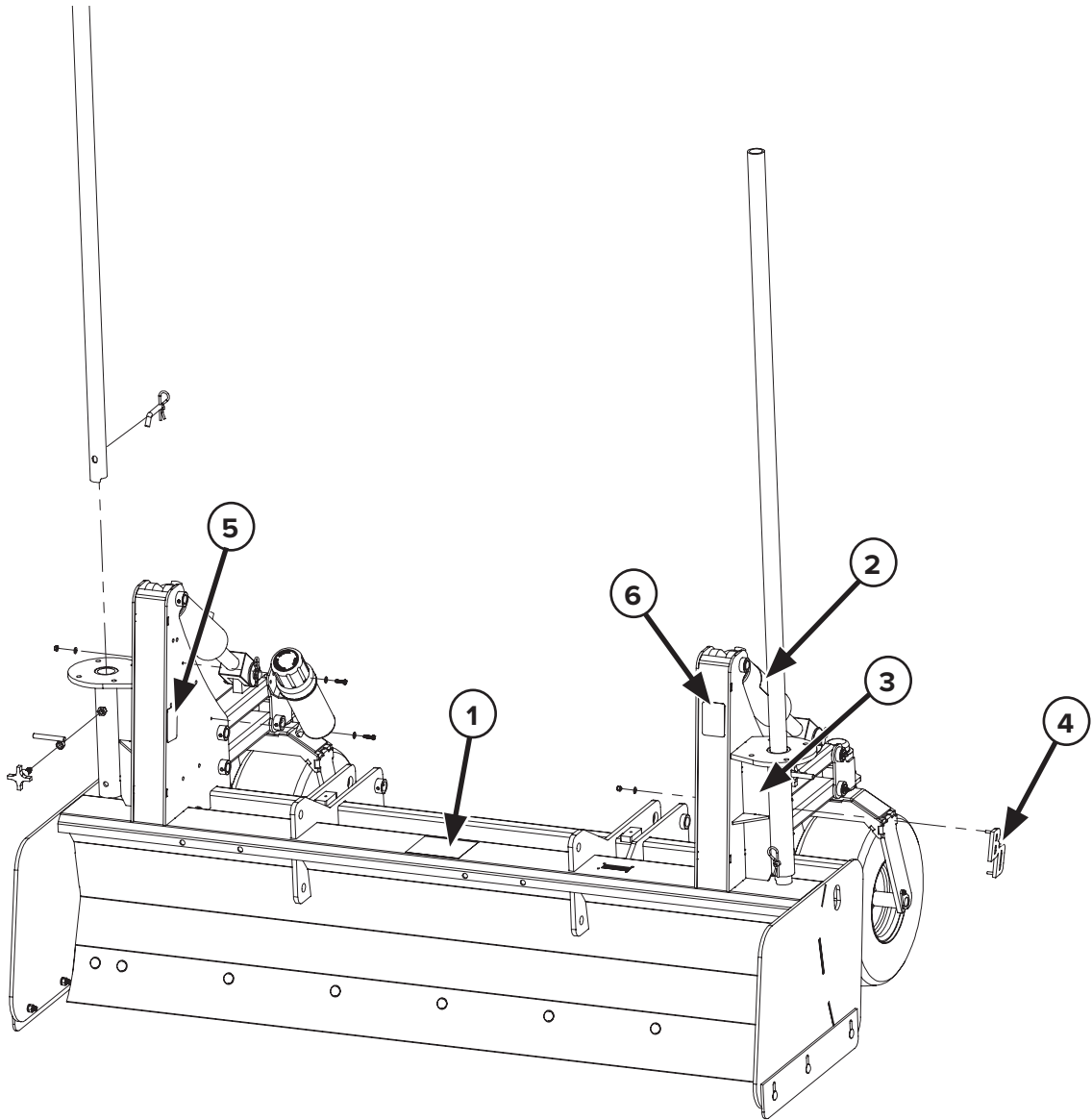

ITEM	PART NUMBER	DESCRIPTION	QTY
1	201091	DECAL, WARNING STAY CLEAR	1
2	223333	DECAL, WARNING: CYLINDER MOVES	2
3	223334	DECAL, WARNING: MOVING PARTS	2
4	223338	BD LOGO ASM, 5 INCH	2
5	219395	DECAL, WARNING: READ MANUAL	1
6	201092	DECAL, STANDARD FLOW	1

6. Parts

6.15 Laser Controller And Receivers

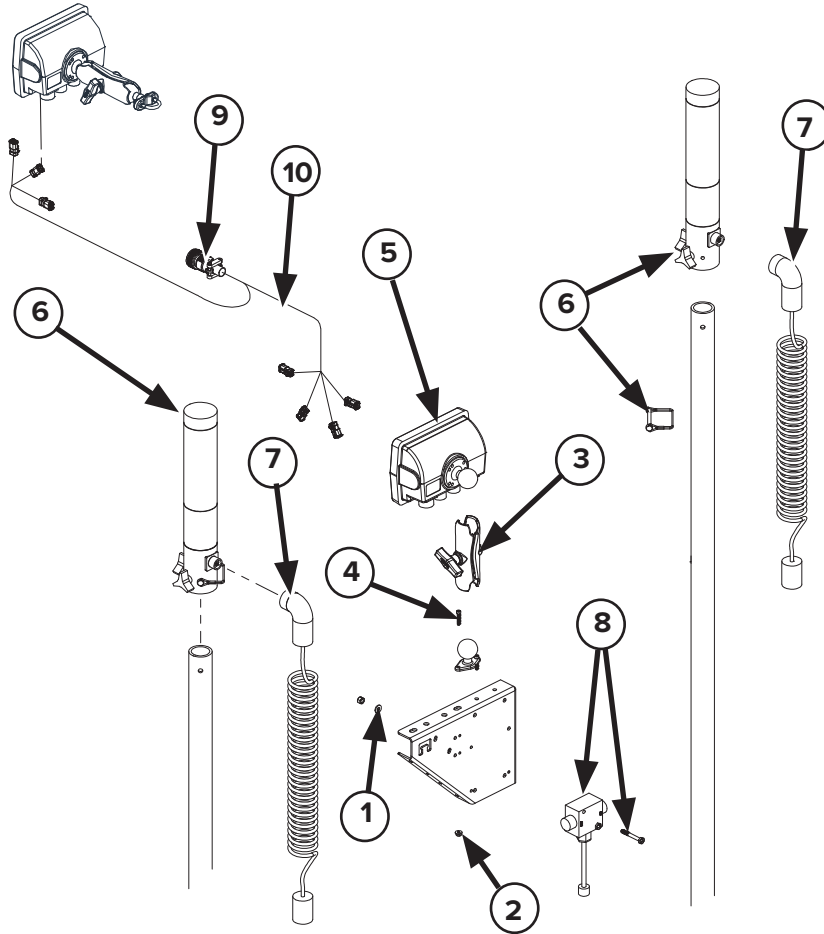

ITEM	PART NUMBER	DESCRIPTION	QTY
1	216405	FLAT WASHER, 1/4" SAE, ZINC	2
2	203427-1N	NYLOCK FLANGE NUT, 10-24, ZINC	2
3	N/A	RAM ARM WITH BALL (Included with 123500 Receiver KIT)	1
4	299407	SOCKET HEAD CAP SCREW, 10-24 X 1", ZINC	2
5	223521	FUTTURA CONTROLLER, EG2	1
6	223522	FUTTURA RECEIVER, 7 IN	2
7	223380	COIL CABLE, FUTTURA EG2 SENSORS	2
8	223381	NODE CABLE, FUTTURA EG2, 18' (Hardware Included)	1
9	260404	HD30 14-PIN FEMALE CONNECTOR	REF
10	223523	VALVE HARNESS, FUTTURA	1

6. Parts

6.16 Baseline Settings for 123500 Laser Kit

NOTE: Go through the settings on the controller box, and set each screen to the values on the right. Afterwards, the settings can be adjusted for preference and machine or jobsite specifications.

Heavy Duty Land Grader	
Baseline Machine Control Setup for 123500 Laser Receiver Kit	
Screen Title	
System Lock Screen Password	1000
Filtering	Fast
Valve Deadband	0.28
Horn	Off
Height Adjustment	On
Unit Selection	Inch
Latec Info Screen	Push MENU & POWER button in Unison to access valve settings
Valve Settings	
Valve 1 Type	Prop Current
Minimum DC	Test
Up	21%
Down	18%
Valve 1 Gain	20%
Derivative Gain	Medium
Auto Return	Off
Tilt Sensing	Off
Factory Settings	Next
Laser Receivers	2
Valve 2 Select	
Valve 2 Type	Prop Current
Minimum DC	Test
Up	21%
Down	18%
Valve 2 Gain	20%
Derivative Gain	Medium
Software Version	
Error Screens	

6. Parts

6.17 Controller Settings - 123500

Valve Connections

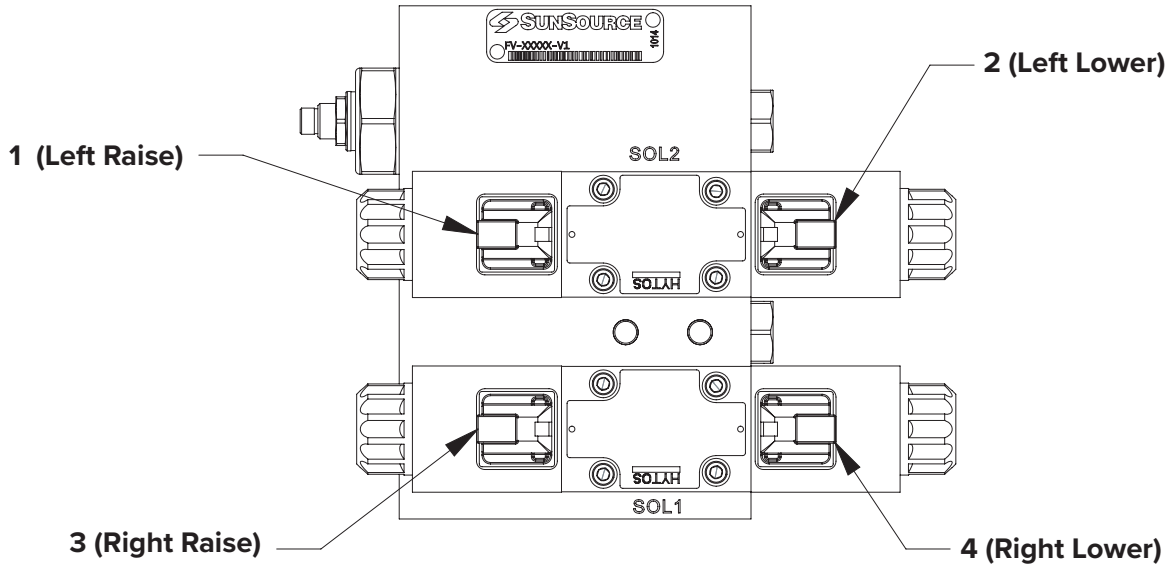

Pin-Out Charts

Bobcat (Requires 7-Pin adapter 160416), Case, Kubota (not SSV/SVL series), Gehl, etc. 14-Pin			
Manual Control Harness – 119215			
Auto/Manual Control Harness – 223523			
Wire Color*	Solenoid Plug	Manual Control	Auto/Manual Control
Green/Gray	1	E	E
Blue/White	2	F	F
Brown/Blue	3	G	G
Yellow/Pink	4	H	H
Purple/Brown	Auto/Manual	---	J**
Red/Red	Power	---	K
Black/Black	Ground	B	B
*Confirm whether your harness uses Left/ or /Right colors			
**Connect to pin C for 160416 Bobcat 7-Pin adapter			

Takeuchi, JCB, Volvo 14-Pin			
Manual Control Harness – 119223			
Auto/Manual Control Harness – 223523			
Wire Color*	Solenoid Plug	Manual Control	Auto/Manual Control
Green/Gray	1	C	C
Blue/White	2	D	D
Brown/Blue	3	E	E
Yellow/Pink	4	F	F
Purple/Brown	Auto/Manual	---	J
Red/Red	Power	---	K
Black/Black	Ground	B	B
*Confirm whether your harness uses Left/ or /Right colors			

6. Parts

6.17 Controller Settings - 123500

Pin-Out Charts, (Con't)

CAT D-Series Dual Joystick Control 14-Pin			
Manual Control Harness – 119225 Auto/Manual Control Harness – 223523			
Wire Color*	Solenoid Plug	Manual Control	Auto/Manual Control
Green/Gray	1	F	F
Blue/White	2	E	E
Brown/Blue	3	D	D
Yellow/Pink	4	C	C
Purple/Brown	Auto/Manual	---	A
Red/Red	Power	---	J
Black/Black	Ground	B	B
*Confirm whether your harness uses Left/ or /Right colors			

ASV 8-Pin and 14-Pin Manual Control			
8-Pin Harness – 119221 14-Pin Harness - 119223			
Wire Color	Solenoid Plug	8-Pin	14-Pin
Green	1	D	E
Blue	2	B	D
Brown	3	G	C
Yellow	4	C	F
Black	Ground	A	B

Kubota SSV/SVL Series 14-Pin			
Manual Control Harness – 119223 Auto/Manual Control Harness – 223523			
Wire Color*	Solenoid Plug	Manual Control	Auto/Manual Control
Green/Gray	1	G	G
Blue/White	2	H	H
Brown/Blue	3	E	E
Yellow/Pink	4	F	F
Purple/Brown	Auto/Manual	---	C
Red/Red	Power	---	K
Black/Black	Ground	B	B
*Confirm whether your harness uses Left/ or /Right colors			

CAT D-Series Single Joystick Control 14-Pin		
Manual Control Harness – 223421		
Solenoid Connections		
Wire Color	Solenoid Plug	Control Input
Green	1	F
Blue	2	E
Brown	3	A + F
Yellow	4	A + E
Black	Ground	B
14-Pin Connections		
Wire Color	Control	Pin
Green	C1	F
Blue	C2	E
Yellow	Trigger	A
Black	(Ground)	B

Deere E/G Series 14-Pin			
Manual Control Harness – 119210 Auto/Manual Control Harness – 223523			
Wire Color*	Solenoid Plug	Manual Control	Auto/Manual Control
Green/Gray	1	E	E
Blue/White	2	D	D
Brown/Blue	3	G	G
Yellow/Pink	4	C	C
Purple/Brown	Auto/Manual	---	L**
Red/Red	Power	---	K
Black/Black	Ground	A	A
*Confirm whether your harness uses Left/ or /Right colors			
**John Deere requires an add-on trigger for Auto/Manual control			

7. Specifications

7.1 Attachment Specifications

Land Grader

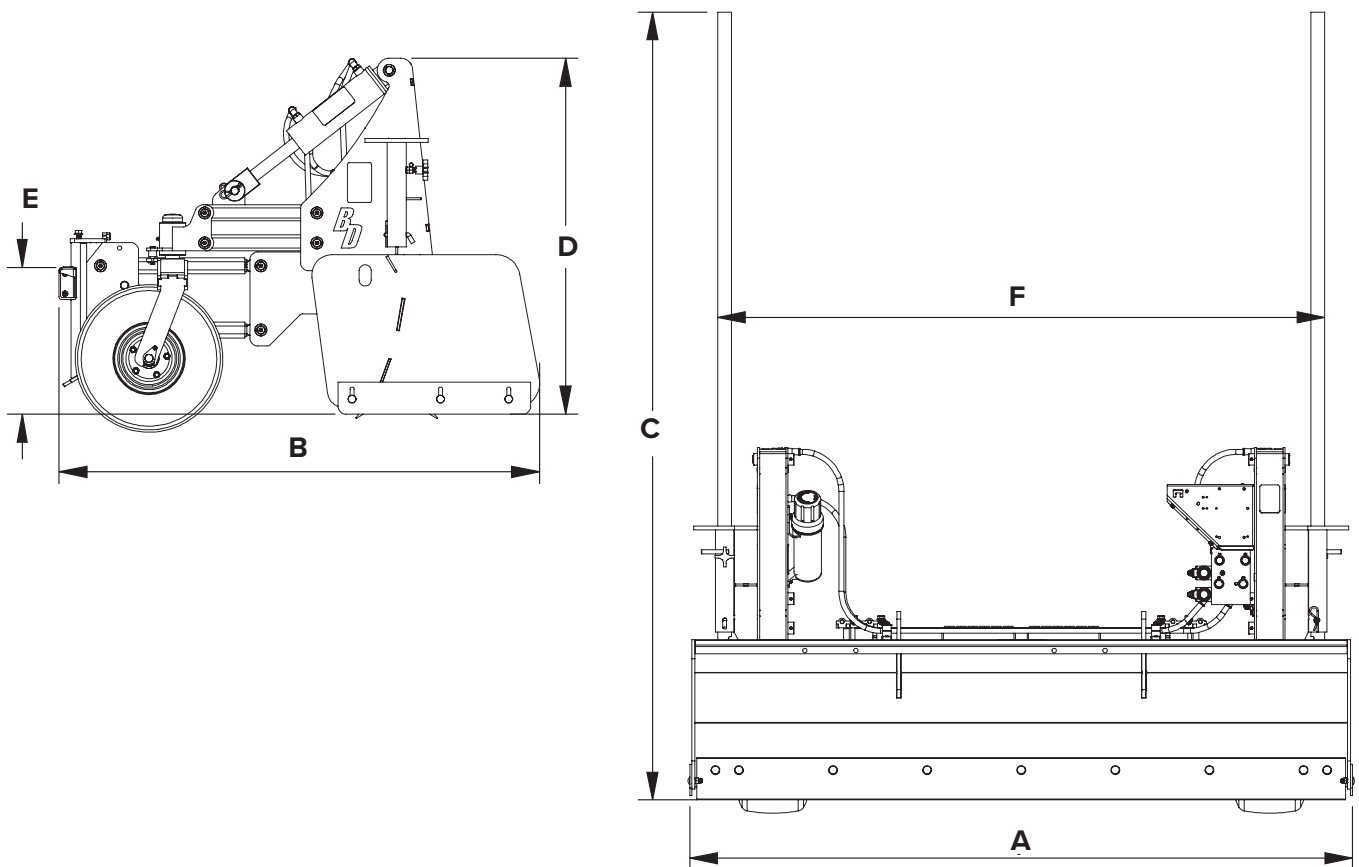

DESCRIPTION	123515
OVERALL WIDTH (A)	84.50 in.
OVERALL LENGTH (B)	60 in.
OVERALL HEIGHT INCL. RECEIVER MAST (C)	100.41 in.
HEIGHT (D)	44.38 in.
STEP HEIGHT (E)	18 in.
OVERALL MAST WIDTH (F)	77.38 in.
WEIGHT	1600 lb.
LAND GRADER BOX CAPACITY	FRONT - 17 cu-ft
	REAR - 10 cu-ft
HORSEPOWER REQUIRED	45 - 70 HP

7. Specifications

7.2 Torque Specifications

Standard Hardware, Lock & Nuts

BOLT								
BOLT TYPE	SAE GRADE 5		SAE GRADE 8		LOCK NUTS			
Nominal Size	Plated or Unplated	Plated W/ ZnCr	Plated or Unplated	Plated W/ ZnCr	Plated or Unplated	Plated W/ ZnCr	W/ Grade 5 Bolt	W/ Grade 8 Bolt
	Silver	Gold	Silver	Gold	Silver	Gold		
1/4	55 ft / lb (6.2 N•m)	72 ft / lb (8.1 N•m)	86 in / lb (9.7 N•m)	112 in / lb (12.6 N•m)	121 in / lb (13.6 N•m)	157 in / lb (17.7 N•m)	61 in / lb (6.9 N•m)	86 in / lb (9.8 N•m)
5/16	115 ft / lb (13 N•m)	149 ft / lb (17 N•m)	178 ft / lb (20 N•m)	229 ft / lb (26 N•m)	250 ft / lb (28 N•m)	325 ft / lb (37 N•m)	125 ft / lb (14 N•m)	176 ft / lb (20 N•m)
3/8	17 ft / lb (23 N•m)	22 ft / lb (30 N•m)	26 ft / lb (35 N•m)	34 ft / lb (46 N•m)	37 ft / lb (50 N•m)	48 ft / lb (65 N•m)	19 ft / lb (26 N•m)	26 ft / lb (35 N•m)
7/16	27 ft / lb (37 N•m)	35 ft / lb (47 N•m)	42 ft / lb (57 N•m)	54 ft / lb (73 N•m)	59 ft / lb (80 N•m)	77 ft / lb (104 N•m)	30 ft / lb (41 N•m)	42 ft / lb (57 N•m)
1/2	42 ft / lb (57 N•m)	54 ft / lb (73 N•m)	64 ft / lb (87 N•m)	83 ft / lb (113 N•m)	91 ft / lb (123 N•m)	117 ft / lb (159 N•m)	45 ft / lb (61 N•m)	64 ft / lb (88 N•m)
9/16	60 ft / lb (81 N•m)	77 ft / lb (104 N•m)	92 ft / lb (125 N•m)	120 ft / lb (163 N•m)	130 ft / lb (176 N•m)	169 ft / lb (229 N•m)	65 ft / lb (88 N•m)	92 ft / lb (125 N•m)
5/8	83 ft / lb (112 N•m)	107 ft / lb (145 N•m)	128 ft / lb (174 N•m)	165 ft / lb (224 N•m)	180 ft / lb (244 N•m)	233 ft / lb (316 N•m)	90 ft / lb (122 N•m)	127 ft / lb (172 N•m)
3/4	146 ft / lb (198 N•m)	189 ft / lb (256 N•m)	226 ft / lb (306 N•m)	293 ft / lb (397 N•m)	319 ft / lb (432 N•m)	413 ft / lb (560 N•m)	160 ft / lb (217 N•m)	226 ft / lb (306 N•m)
7/8	142 ft / lb (193 N•m)	183 ft / lb (248 N•m)	365 ft / lb (495 N•m)	473 ft / lb (641 N•m)	515 ft / lb (698 N•m)	667 ft / lb (904 N•m)	258 ft / lb (350 N•m)	364 ft / lb (494 N•m)
1	213 ft / lb (289 N•m)	275 ft / lb (373 N•m)	547 ft / lb (742 N•m)	708 ft / lb (960 N•m)	773 ft / lb (1048 N•m)	1000 ft / lb (1356 N•m)	386 ft / lb (523 N•m)	545 ft / lb (739 N•m)



Warranty

MANUFACTURER'S LIMITED WARRANTY

BLUE DIAMOND® ATTACHMENTS, a manufacturer of quality attachments, warrants new BLUE DIAMOND® ATTACHMENTS products and/or attachments at the time of delivery to the original purchaser, to be free from defects in material and workmanship when properly set up and operated in accordance with the recommendations set forth by BLUE DIAMOND® ATTACHMENTS, LLC.

BLUE DIAMOND® ATTACHMENTS liability for any defect with respect to accepted goods shall be limited to repairing the goods at a BLUE DIAMOND® ATTACHMENTS designated location or at an authorized dealer location, or replacing them, as BLUE DIAMOND® ATTACHMENTS shall elect. The above shall be in accordance with BLUE DIAMOND® ATTACHMENTS warranty adjustment policies. BLUE DIAMOND® ATTACHMENTS obligation shall terminate twelve (12) months for the Heavy Duty Land Grader after the delivery of the goods to original purchaser.

This warrant shall not apply to any machine or attachment which shall have been repaired or altered outside the BLUE DIAMOND® ATTACHMENTS factory or authorized BLUE DIAMOND® ATTACHMENTS dealership or in any way so as in BLUE DIAMOND® ATTACHMENTS judgment, to affect its stability or reliability, nor which has been subject to misuse, negligence or accident beyond the company recommended machine rated capacity.

WARRANTY CLAIM

To submit a warranty claim, a return authorization from BLUE DIAMOND® ATTACHMENTS must be obtained. The failed part may then be returned. Tampering with the failed part may void the warranty. This warranty does not include freight or delivery charges incurred when returning machinery for servicing. Dealer mileage, service calls, and pickup/delivery charges are the customers' responsibility.

EXCLUSIONS OF WARRANTY

Except as otherwise expressly stated herein, BLUE DIAMOND® ATTACHMENTS makes no representation or warranty of any kind, expressed or implied, AND MAKES NO WARRANTY OF MERCHANTABILITY IN RESPECT TO ITS MACHINERY AND/OR ATTACHMENTS ARE FIT FOR ANY PARTICULAR PURPOSE. BLUE DIAMOND® ATTACHMENTS shall not be liable for incidental or consequential damages for any breach or warranty, including but not limited to inconvenience, rental of replacement equipment, loss of profits or other commercial loss. Upon purchase, the buyer assumes all liability for all personal injury and property resulting from the handling, possession, or use of the goods by the buyer.

No agent, employee, or representative of BLUE DIAMOND® ATTACHMENTS has any authority to bind BLUE DIAMOND® ATTACHMENTS to any affirmation, representation, or warranty concerning its machinery and/or attachments except as specifically set forth herein.

This warranty policy supersedes any previous documents.

NOTE: Blue Diamond® Attachments is a trademark of BLUE DIAMOND® ATTACHMENTS.



QUALITY | DEPENDABILITY | INTEGRITY

Blue Diamond® Attachments
4512 Anderson Road, Knoxville, TN 37918
888-376-7027