

6-Way Dozer Blade

Operation and Maintenance Manual

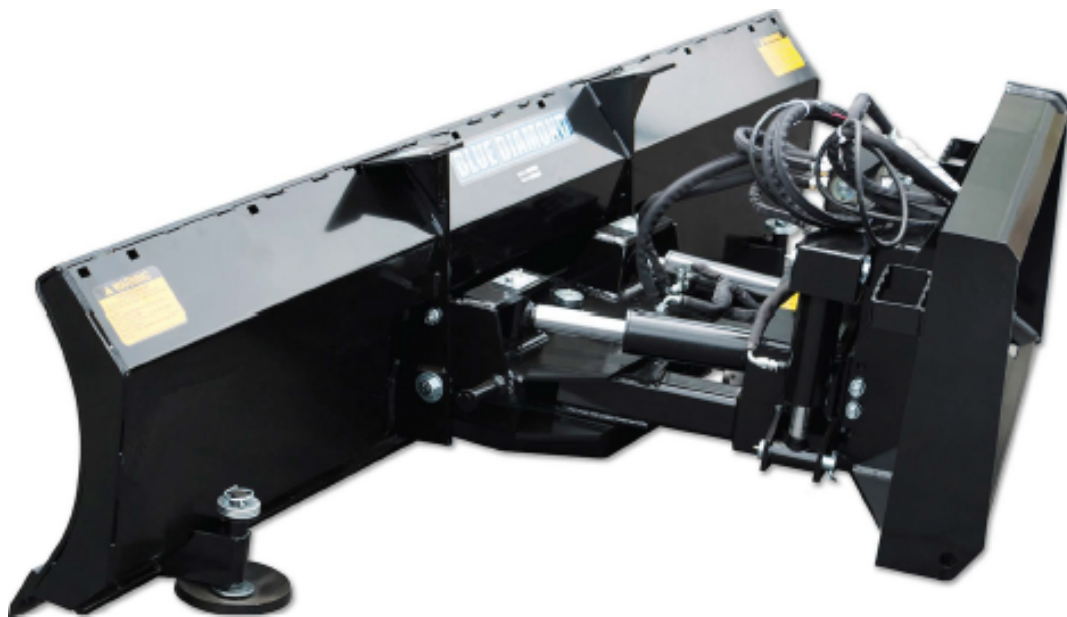

*Register your
WARRANTY
within 30 days
of purchase*



888-376-7027 | BlueDiamondAttachments.com



BD-092

TABLE OF CONTENTS

1. About this Manual	3	5.5 Manifold Assembly	30
1.1 Attachment Identification	4	5.6 Universal Control Kit Option	31
1.2 Standard Models.....	5	5.7 OEM Harness Option.....	32
1.3 Standard Items	5	5.8 Trip Springs Option	33
1.4 Options.....	5	5.9 Blade Extension Option	34
2. Safety	6	5.10 Decal Identification and Location	35
2.1 Importance of Safety	7-8	6. Specifications	36
3. Operation	9	6.1 Attachment Specifications	36
3.1 OEM Harness Option	9	6.2 Dimensions	37-38
3.2 Universal Harness Kit Installation Option.....	10	6.3 Torque Specifications	39
3.3 General Information.....	11	7. Warranty	40
3.4 Attachment Inspection.....	12		
3.5 Attachment Installation.....	13-15		
3.6 Operating the Attachment.....	16		
3.7 Attachment Removal	17		
4. Maintenance	18		
4.1 Maintenance Safety.....	18		
4.2 Lubrication.....	19-20		
4.3 Troubleshooting	21		
4.4 Storage and Return to Service	22		
5. Parts.....	23		
5.1 Skid Plate and Cutting Edge.....	23		
5.2 Blade/Frame Parts	24-25		
5.3 Blade/Frame Hardware	26-27		
5.4 Hydraulic Valve/Cylinder Plumbing	28-29		

Owner Information

Thank you for your decision to purchase a Blue Diamond 6-Way Dozer Blade. To ensure maximum performance of your equipment, it is mandatory that you thoroughly study the Operator's Manual and follow the recommendations. Proper operation and maintenance are essential to maximize equipment life and prevent personal injury.

Operate and maintain this equipment in a safe manner and in accordance with all applicable local, state, and federal codes, regulations and / or laws. Follow all on-product labeling and instructions.

Make sure that all personnel have read this Operator's Manual and thoroughly understand safe and correct operating, installation and maintenance procedures.

Blue Diamond is continually working to improve its products. Blue Diamond reserves the right to make any improvements or changes as deemed practical and possible without incurring any responsibility or obligation to make any changes or additions to equipment sold previously.

Although great care has been taken to ensure the accuracy of this publication, Blue Diamond makes no warranty or guarantee of any kind, written or expressed, implied or otherwise with regard to the information contained within this manual. Blue Diamond assumes no responsibility for any errors that may appear in this manual and shall not be liable under any circumstances for incidental, consequential or punitive damages in connection with, or arising from the use of this manual.

Keep this manual available for frequent reference. All new operators or owners must review the manual before using the equipment and annually thereafter. Contact your Blue Diamond Attachments Dealer for assistance, information, or additional copies of the manual. Contact www.bluediamondattachments.com or call 888-376-7027 for a complete list of dealers in your area.

Serial Number Location

Please record attachment information in the space provided for future reference.

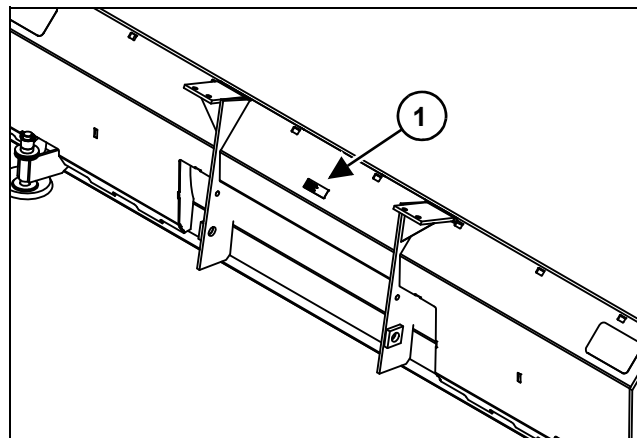

Figure 1

Model Number: _____

Serial Number: _____

Dealer Name: _____

Dealer Number: _____

Date of Purchase: _____

The serial number plate (Item 1) [Figure 1] is located on the rear of the dozer blade frame.

Always use the serial number of the 6-way dozer blade when requesting service information or when ordering parts. Early or later models (identification made by serial number) may use different parts, or may require a different procedure in doing a specific service operation.

Attachment Identification

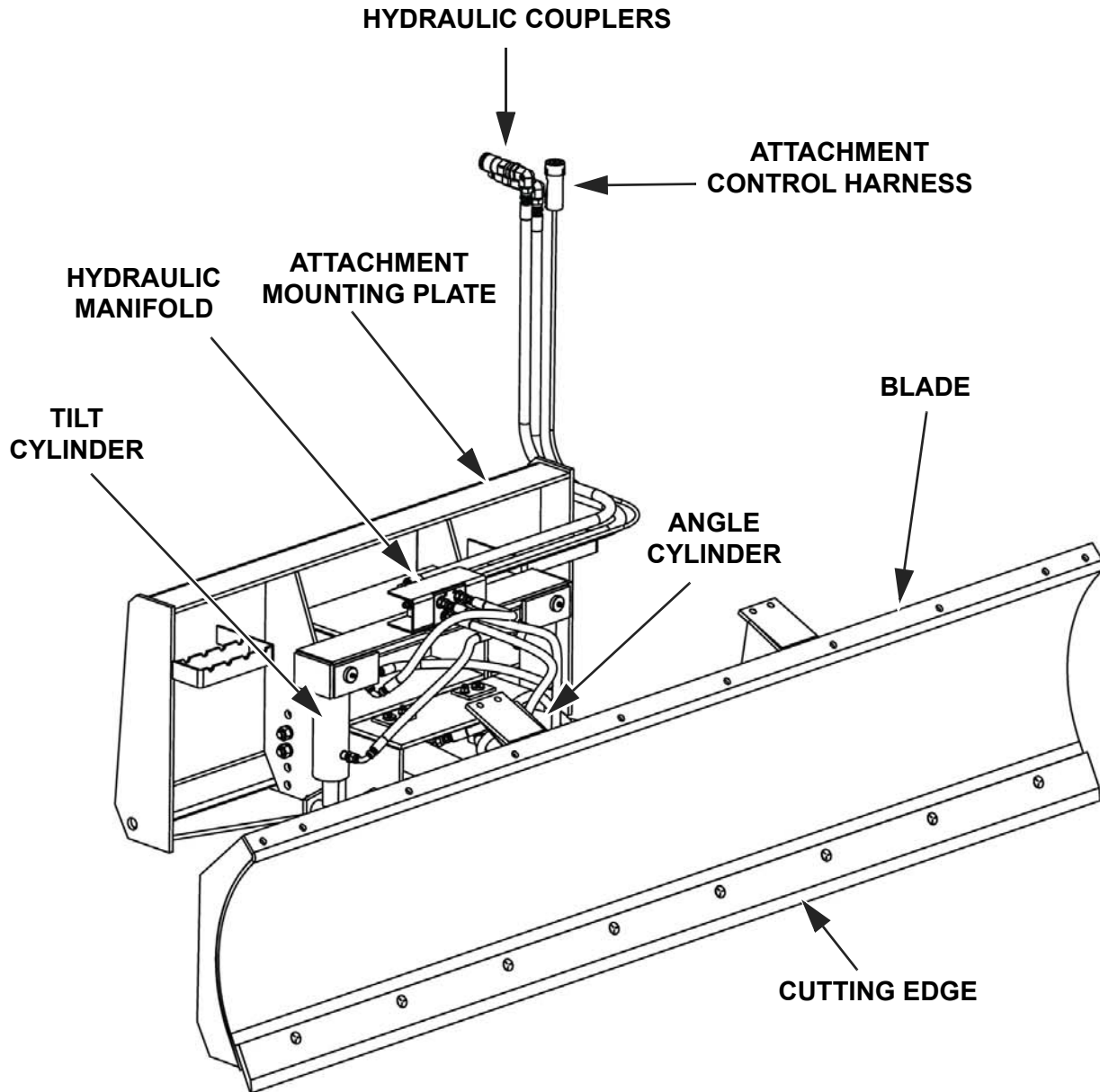

Standard Models

5-FT 6-Way Dozer Blade

6-FT 6-Way Dozer Blade

7-FT 6-Way Dozer Blade

8-FT 6-Way Dozer Blade

Standard Items

- Bolt-on, Cutting Edge
- Adjustable / Replaceable Skid Plates
- Removable Quick-Tach Mounting Frame
- Lock Out Bolts
- Electro-Hydraulic Controls

Options

- Quick Change Trip Springs
- Rubber Cutting Edge
- 8 Inch Blade Extension

Control Harnesses:

- Universal Control Harness Kit
- OEM Harness

NOTE: A universal control kit or OEM harness option is required. (See “Universal Control Kit (Option)” on page 47.) **or** (See “OEM Harness (Option)” on page 48.)

Safety Information



SAFETY ALERT SYMBOL

This **SAFETY ALERT SYMBOL** identifies important safety messages on the equipment and in the owner's manual. When you see this symbol, be alert to the possibility of personal injury and carefully read the message that follows.



DANGER

The signal word **DANGER** on the machine and in the manuals indicates a hazardous situation which, if not avoided, will result in death or serious injury.



WARNING

The signal word **WARNING** on the machine and in the manuals indicates a potentially hazardous situation which, if not avoided, could result in death or serious injury.



CAUTION

The signal word **CAUTION** on the machine and in the manuals indicates a potentially hazardous situation which, if not avoided, may result in minor or moderate injury. It may also be used to alert against unsafe practices.



IMPORTANT

The signal word **IMPORTANT** identifies procedures which must be followed to avoid damage to the machine.

Safe Operation Needs A Qualified Operator



WARNING

AVOID SERIOUS INJURY OR DEATH

Operators must receive instructions before operating the machine. Untrained operators can cause serious injury or death.

For an operator to be qualified, he or she must not use drugs or alcoholic drinks which impair alertness or coordination while working. An operator who is taking prescription drugs must get medical advice to determine if he or she can safely operate a machine and the equipment.

Operator Training

- Check the rules and regulations at your location. The rules may include an employer's work safety requirements. Regulations may apply to local driving requirements or use of a Slow Moving Vehicle (SMV) emblem. Regulations may identify a hazard such as a utility line.
- The new operator must start in an area without bystanders and use all the controls until he or she can operate the machine safely under all conditions of the work area.

Importance of Safety

Operating Safety

- Read and follow instructions in this manual and the machine's Operators Manual before operating.
- Under no circumstances should young children be allowed to work with this equipment.
- This equipment is dangerous to persons unfamiliar with its operation.
- Check for overhead and / or underground lines before operating equipment (if applicable).
- In addition to the design and configuration of equipment, hazard control and accident prevention are dependent upon the awareness, concern, prudence and proper training of personnel involved in the operation, transport, maintenance and storage of equipment.
- Check that the attachment is securely fastened to the machine.
- Make sure all the machine controls are in the NEUTRAL before starting the machine.
- Operate the equipment only from the operator's position.
- Operate the equipment according to the Operator's Manual.
- When learning to operate the equipment, do it at a slow rate in an area clear of bystanders.
- DO NOT permit personnel to be in the work area when operating the equipment.
- The equipment must be used ONLY on approved machines.
- DO NOT modify the equipment in any way. Unauthorized modification may impair the function and / or safety and could affect the life of the equipment.
- DO NOT make any adjustments or repairs on the equipment while the machine is running.
- Keep shields and guards in place. Replace if damaged.
- DO NOT operate equipment in poor visibility conditions such as fog, darkness, or any conditions that limit clear visibility less than 300 feet (100 m) in front of and to the sides of the equipment.
- DO NOT operate in a work area that has not been inspected for foreign debris and obstacles.
- Remove any foreign objects and clearly mark any objects that cannot be removed.
- Wear safety glasses, gloves, hearing protection and other protective clothing when required.

Importance of Safety Cont'd

Fire Prevention Safety

- Flammable debris (leaves, grass, etc.) must be removed regularly. If flammable debris is allowed to accumulate, it can cause a fire hazard. Clean often to avoid this accumulation.
- The equipment's hydraulic motor compartment must be inspected every day and cleaned if necessary to prevent fire hazards and overheating.
- All fuels, most lubricants and some coolant mixtures are flammable. Flammable fluids that are leaking or spilled onto hot surfaces or onto electrical components can cause a fire.

Transporting Safety

- Comply with state and local laws governing highway safety and movement of machinery on public roads.
- Check local laws for all highway lighting and marking requirements.
- Always yield to oncoming traffic and move to the side of the road so any following traffic may pass.
- Never allow riders on either machine or equipment.
- If transporting the 6-way dozer blade on a truck or trailer, make sure it is properly secured to the transport vehicle.

Hydraulic Safety

- Check hydraulic tubes, hoses and fittings for damage and leakage. Never use open flame or bare skin to check for leaks. Hydraulic tubes and hoses must be properly routed and have adequate support and secure clamps. Tighten or replace any parts that show leakage.
- Always clean fluid spills. Do not use gasoline or diesel fuel for cleaning parts. Use commercial nonflammable solvents.

OEM Harness Installation (Option)

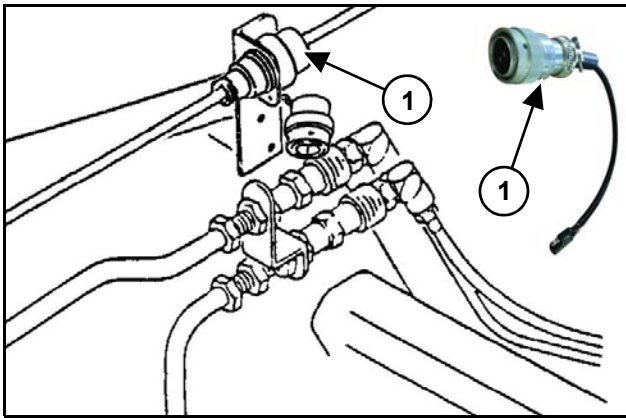

Figure 2

The OEM harness (Item 1) **[Figure 2]** connects to the plug coming up from the dozer blade and the electrical receptacle connector located on the machine.

Universal Harness Kit Installation (Option)



Figure 3

Harness (Item 1) [Figure 3] connects to the machines power point connection.



Figure 5

Harness (Item 3) [Figure 5] located on attachment diverter valve can run directly to the cab and connect to (Item 2) [Figure 4].



Figure 4

Switch box (Item 2) [Figure 4] connects to the machines power point connection. Place the switch box in an easy access location.

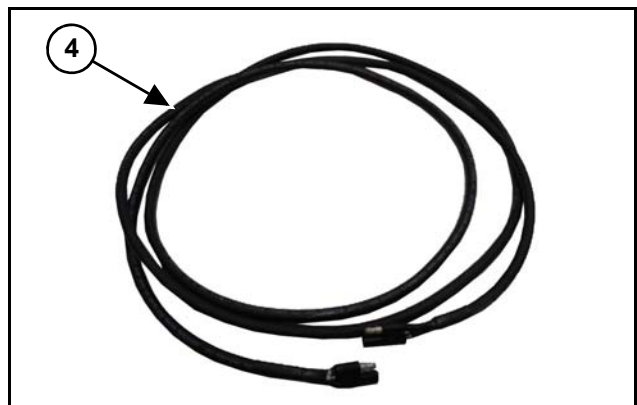

Figure 6

Harness (Item 4) [Figure 6] is optional, this harness can be used if desired to route harness (Item 3) [Figure 5] with the hydraulic hoses along the loader arms to the back pivot point, (versus routing directly into the cab).

General Information

Pre-Operation Inspection

Before operating the 6-way dozer blade for the first time and each time thereafter, use the following list as a guideline during equipment inspection.

1. Use only a machine of adequate power and weight to operate the 6-way dozer blade.
2. Check the 6-way dozer blade and machine’s quick tach mounts for damaged, loose or missing parts. Repair as needed before operation.
3. Lubricate the equipment per the schedule outline in the Maintenance Section.
4. Check that the 6-way dozer blade is properly attached to the machine. Be sure retainers are used on the mounting pins.
5. Check that skid plates are set at the same working depth.
6. Make sure that all guards and shields are in place, secured and functioning as designed.
7. Check oil level in machine’s hydraulic reservoir.
8. Check that the hydraulic couplers are securely attached to the 6-way dozer blade and to the machine. Make sure hoses are routed and secured to avoid pinch points or strain during movement of the machine/attachment.
9. Check cutting blade for wear or damage.
10. Check wire harness for damage and make sure all harness connections are secure.
11. Check hydraulic lines, connections and fittings for hydraulic oil leaks.



Leaking fluids under pressure can enter the skin and cause serious injury or death. Immediate medical attention is required. Wear goggles. Use cardboard to check for leaks.

Machine Requirements

6-WAY DOZER BLADE	HP REQUIRED
6-FT	50+ HP
7-FT	50+ HP
8-FT	50+ HP

Attachment Inspection

Daily Inspection

NOTE: Inspect the attachment by performing a walk around daily before and after use. Use the following inspection checklist as a guideline.

Check the following items every 10 hours of operation:

- Verify that the 6-way dozer blade is properly connected to the machine.
- Check that all shields and guards are in place.
- Check for damaged or leaking hydraulic hoses or fittings. Replace if necessary.
- Check cutting edge for wear or damage. Replace if necessary.
- Check the 6-way dozer blade mounting hardware for wear or damage. Inspect the pins and mount (on the attachment) for wear or damage. Repair or replace damaged parts if necessary.

Monthly Inspection

- Inspect the dozer blade for cracks, bends, or excessive wear.
- Check skid plates for wear.
- Check that all bolts are tight.
- Check blade and mounting plate for cracks or damage. Replace if necessary.
- Check hydraulic lines, connections and fittings for hydraulic oil leaks. Repair or replace damaged parts if necessary.
- Check for damaged or missing decals. Replace if necessary.
- Lubricate as required.



WARNING



AVOID SERIOUS INJURY OR DEATH

Before servicing the attachment:

- **Always park on a flat level surface.**
- **Lower lift arms and place attachment flat on the ground.**
- **Place all controls in NEUTRAL.**
- **Engage the park brake.**
- **Wait for all moving parts to stop.**
- **Stop the engine and remove the key.**

SEE MACHINE'S OPERATOR'S MANUAL FOR ADDITIONAL INFORMATION.

Attachment Installation



IMPORTANT



See the machine's Operator's Manual for detailed information on operating the loader.

Entering The Operator's Position

Use the attachment safety treads, handles and steps (on the machine) to enter the operator's position.

When in the operator's position, lower safety seat bar, start the engine and release the parking brake.

Leaving The Operator's Position



WARNING



AVOID SERIOUS INJURY OR DEATH

Before leaving the operator's position:

- Always park on a flat level surface.
- Lower lift arms and place attachment flat on the ground.
- Place all controls in **NEUTRAL**.
- Engage the park brake.
- Stop the engine and remove the key.
- Wait for all moving parts to stop.

SEE MACHINE'S OPERATOR'S MANUAL FOR ADDITIONAL INFORMATION.

Park the machine / attachment on a flat level surface.

Place all controls in neutral, engage the park brake, stop the engine and wait for all moving parts to stop. Leave the operator's position.

Connecting Attachment To The Machine



WARNING



CRUSH HAZARD

- Before moving the machine, look in all directions and make sure no bystanders, especially small children are in the work area. Do not allow anyone between the machine and attachment when approaching the attachment for connecting.
- Keep fingers and hands out of pinch points when connecting and disconnecting attachment.

Before connecting to the attachment, inspect the machine's mounting plate. (See the machine's Operator's Manual for inspecting the mounting frame).

Enter the operator's position. See "Entering The Operator's Position" on page 23.

Lower the machine's lift arm and tilt the machine's mounting plate forward.

Drive the machine slowly forward until the top edge of the machine's mounting frame is completely under the mounting flange of the 6-way dozer blade mounting frame.

Slowly raise and tilt the machine's mounting plate back until the 6-way dozer blade is slightly off the ground and attachment mounting frame fully contacts the front of the machine's mounting plate.

Connecting Attachment To The Machine Cont'd

Stop the engine and engage the parking brake.

Leave the operator's position. See "Leaving The Operator's Position" on page 23.

Engage machine's locking levers / wedges to securely fasten the 6-way dozer blade to the machine's mounting frame. (See the machine's Operation Manual for the correct procedure.)

Visually inspect that the wedge pins are securely fastened into the 6-way dozer blade mounting frame.



WARNING

AVOID SERIOUS INJURY OR DEATH

The locking pins / wedges must extend through the holes in the attachment mounting frame. Failure to secure locking pins / wedges can allow attachment to come off.

SEE MACHINE'S OPERATOR'S MANUAL FOR ADDITIONAL INFORMATION.

Engage machine's locking levers / wedges (See the machine's Operator's Manual for detailed information).

Hydraulic Couplers and Attachment Control Harness



IMPORTANT

- Thoroughly clean the quick couplers before making connections. Dirt can quickly damage the hydraulic system.

Connecting Hydraulic Couplers:

NOTE: The dozer blade is supplied with flush face couplers.

NOTE: DO NOT attach hoses to high flow lines on a machine equipped with the High Flow Option.

Remove any dirt or debris from the surface of both the male and female couplers, and from the outside diameter of the male coupler. Visually check the couplers for corroding, cracking, damage, or excessive wear. If any of these conditions exist, replace the coupler(s).

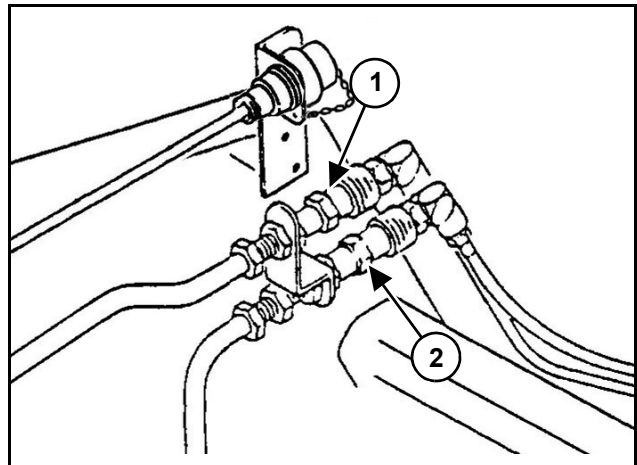

Figure 7

Install the 6-way dozer blade male coupler (Item 1) [Figure 7] into the female coupler. Pull on the coupler connection to verify that the male and female couplers are securely fastened.

Install the 6-way dozer blade female coupler (Item 2) [Figure 7] onto the male coupler. Pull on the coupler connection to verify that the male and female couplers are securely fastened.

Connecting Attachment To The Machine Cont'd

Attaching Control Harness:

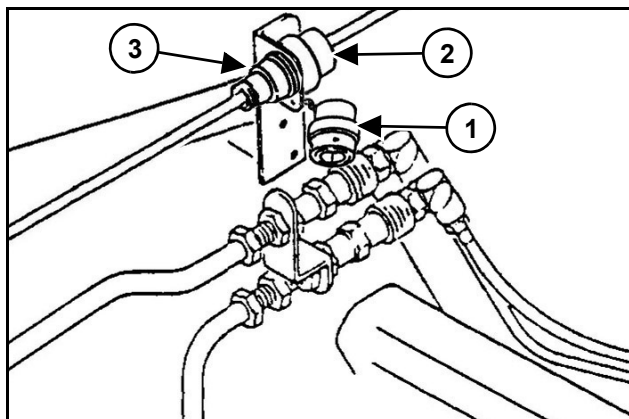

Figure 8

Remove dust cap (Item 1) from control harness (Item 2) [Figure 8].

Attach dozer blade harness (Item 2) to control harness (Item 3) [Figure 8] (if the OEM harness option is used).

Attach dozer blade harness to the machine's power point connection (if the universal harness kit is used).

Checking 6-Way Dozer Blade Operation

NOTE: After installing the 6-way dozer blade, test all 6-way dozer blade functions before operating the 6-way dozer blade in the work area.



WARNING

AVOID INJURY OR DEATH

- Never start the machine from outside the cab.
- Never operate the machine if any safety device is damaged, disconnected or missing.
- Never exit the machine with the engine running.

The auxiliary (remote) control on the machine is used to angle the blade right and left and tilt the blade up or down.

NOTE: The default function (without electrical hooked up) is tilt. Angle of the blade is only possible while providing a constant 12 volts to the blade while running the auxiliary hydraulics in one direction, for right angle and the other direction for left angle. The electrical needs to be released or turned off to go back to the tilt function.

The switch mounted to the machine's LH control lever is used to select blade angle to blade tilt.



IMPORTANT



It is the operator's responsibility to know which machine control operates each function of the attachment prior to operating the attachment in the work area.

Engage the machine's auxiliary hydraulics. (See the machine's Operation Manual for correct procedure).

Raise the engine RPM.

Check the controls of the 6-way dozer blade for proper operation.

Exit the machine. (See "Leaving The Operator's Position" on page 23.)

Adjust the skid plates to desired height. (See "Skid Plate Adjustment / Replacement" on page 33.)

NOTE: Skid plates must be set to the same height.

Move the machine and 6-way dozer blade to the work area.

Operating The Attachment

Operation



WARNING



AVOID BURNS

Warnings on the machine and in the manuals are for your safety. Failure to obey warnings can cause serious injury or death.



WARNING



AVOID INJURY OR DEATH

While operating the machine:

- Always keep seat belt fastened.
- Safety seat bar lowered (if equipped)

Always keep your feet on the pedals or footrests and hands on the controls

Adjust skid plates to desired height. (See “Skid Plate Adjustment / Replacement” on page 33.)

Enter the machine. (See “Entering The Operator’s Position” on page 23.)

Start the engine and release the parking brake.

Engage the machine’s auxiliary hydraulics. (See the machine’s Operation Manual for correct procedure.)

Raise the dozer blade slightly off the ground.

With the machine’s auxiliary (remote) control, set the desired left/right blade angle and up/down tilt.

With the switch mounted to the machine’s LH control lever, adjust desired left/right blade angle / tilt.

NOTE: The machine speed is determined by the depth and density of the material being moved.

NOTE: Use the float position (on the control valve) to remove material without moving the actual surface material.

NOTE: Always use the float position (on the control valve) when back blading.

NOTE: Always use the float position (on the control valve) when moving snow.

Attachment Removal

NOTE: Put the 6-way dozer blade on planks or blocks before removing it from the machine to prevent it from settling or sinking in soft / wet ground.

Park the machine and attachment on a flat level surface.

Lower the lift arms and put the 6-way dozer blade flat on the ground.

Stop the engine and engage the parking brake.

Relieve auxiliary hydraulic pressure. (See the machine's Operator's Manual for correct procedure.)

Leave the operator's position. (See "Leaving The Operator's Position" on page 23.)

Disconnect the auxiliary hydraulic hoses and attachment control harness. (**See "Hydraulic Couplers and Attachment Control Harness" on page 24.**)

Disengage the attachment locking levers / wedges. (See the machine's Operator's Manual for correct procedure.)



WARNING



AVOID BURNS

Hydraulic fluid, tubes, fittings and quick couplers can get hot during operation. Be careful when connecting and disconnecting hydraulic hoses.

Enter the machine. (See "Entering The Operator's Position" on page 23.)

Start the engine and release the parking brake.

Engage the machine's auxiliary hydraulics. (See the machine's Operation Manual for correct procedure.)

Slowly tilt the machine's mounting plate forward until the attachment mounting frame is free from the machine's mounting plate.

Drive the machine slowly backward, away from the attachment.

Maintenance Safety



AVOID SERIOUS INJURY OR DEATH

Never operate the machine in a closed building. Proper ventilation is required when operating the machine under all circumstances.

- Always keep the work area clean and dry.
- Always use personal protection devices such as eye, hand and hearing protection when performing any service or maintenance.
- A fire extinguisher and first aid kit should be readily accessible while performing maintenance on this machine.
- Before working or doing maintenance on this machine, shut off the engine and remove the key. Make sure the machine's wheels are blocked.
- Never work under the machine or attachment unless the machine or equipment is blocked or supported securely.
- Disconnect the battery (both terminals) before welding on any part of the machine. Failure to do so may cause damage to electrical components.
- When working around batteries, remember that all of the exposed metal parts are "live". Never lay a metal object across the terminals because a spark, short circuit, explosion or personal injury may result.
- Battery posts, terminals and related accessories contain lead and lead compounds. **Wash hands after handling.**
- Always relieve hydraulic system pressure before repairing, adjusting or disconnecting. Never search for leaks with your hands. (See "Hydraulic Safety" on page 15.)
- When replacement parts are necessary, genuine factory replacement parts must be used to restore your equipment to original specifications. Blue Diamond will not be responsible for injuries or damage caused by use of unapproved parts and / or accessories.

- When completing service or maintenance on this machine, make sure all shields and guards are installed before placing the machine into service.

General Maintenance



AVOID SERIOUS INJURY OR DEATH

Before operating or servicing system: Read and understand the machine's owners manual. Follow the warnings and instructions in the manual when making repairs, adjustments, or servicing. Check for correct function after adjustments, repairs or service. Untrained operators and failure to follow instructions can cause injury or death.

To ensure efficient operation, you should inspect, lubricate, and make necessary adjustments and repairs at regular intervals. Keep good maintenance records and adequately clean your machine after each use.

Proper lubrication is important. Follow all lubrication instructions and schedules included in this section.

Daily Inspection:

- All components and hardware to ensure equipment is secure and thoroughly tightened.
- Frame and all welds for cracks or damage.
- Skid plates for wear or damage.
- Mounting frame for proper operation and signs of damage or unusual wear.
- Safety signs and reflectors for damage. Replace any missing or damaged decals.
- Cutting edge for wear or damage.
- Hydraulic hoses and fittings for wear, damage or leaks.

NOTE: Repair or replace any damaged parts.

NOTE: After initial use, or repair/replacement of damaged parts, it is important to check the repaired or replaced parts for proper bolt torque and operation.

Lubrication

Always use a quality lithium base multi purpose grease when lubricating the machine.



WARNING



AVOID SERIOUS INJURY OR DEATH

Always turn off and lockout power before servicing the 6-way dozer blade.



WARNING



AVOID SERIOUS INJURY OR DEATH

Securely block up the attachment before working underneath.

Grease Points

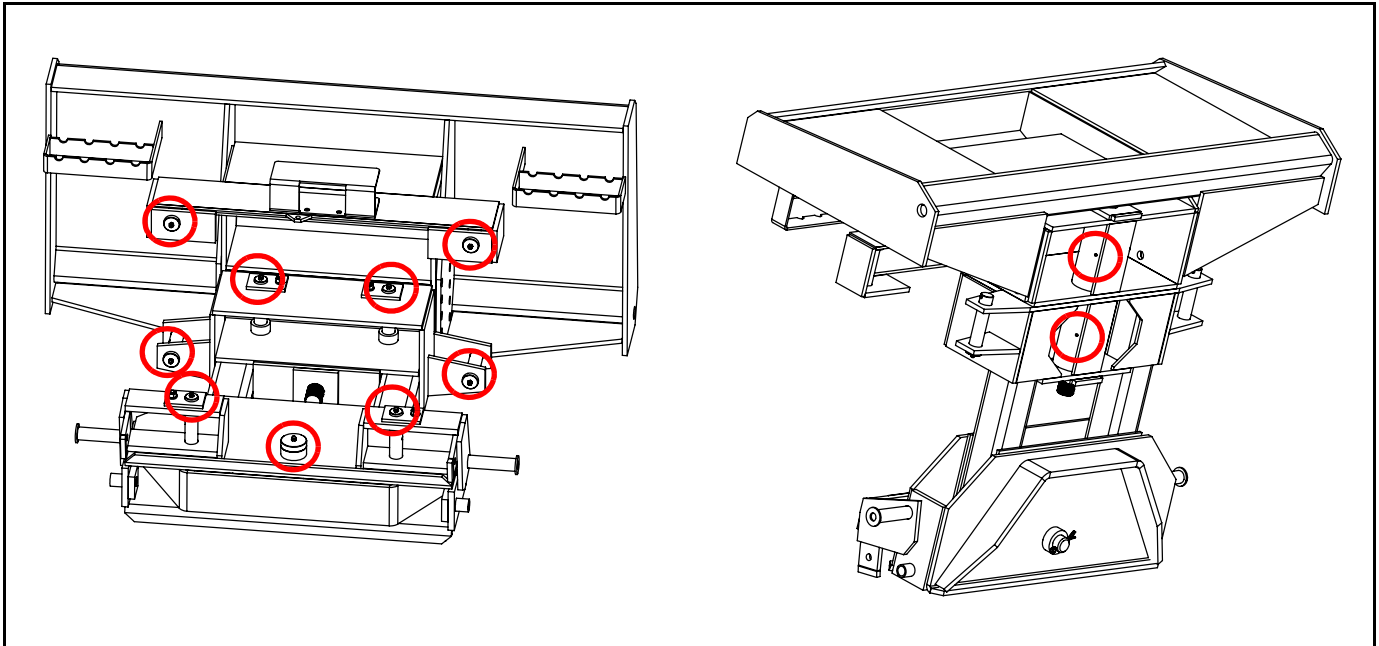

Figure 9

Grease the eleven grease points **EVERY 40 HOURS** of operation [Figure 9].

Cutting Edge Replacement



AVOID SERIOUS INJURY OR DEATH

Securely block up the attachment before working underneath.

1. Park the machine on a level surface with the 6-way dozer blade properly attached.
2. Lower the 6-way dozer blade's rear skid plates onto two equal blocks approximately 2 to 3 inches in height and capable of sufficiently supporting the unit's weight.
3. Engage the parking brake.
4. Shut off the machine's engine, remove the starter key, wait for all moving parts to come to a stop and relieve all pressure in the hydraulic lines.

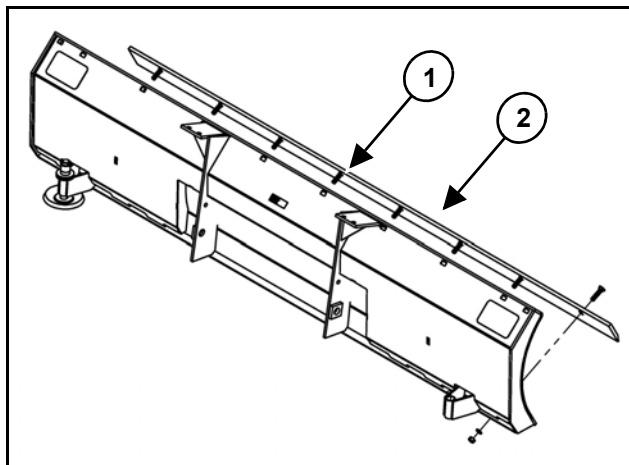

Figure 10

5. Remove all fasteners (Item 1) except the fasteners at each end of the cutting edge (Item 2) [Figure 10].
6. Remove one fastener at the end of the cutting edge and lower the cutting edge to the work surface. Then remove the remaining fastener.

7. Properly dispose of the old cutting edge and install a new cutting edge by reversing the steps listed here.

NOTE: Replace worn or damaged fasteners as needed.

Skid Plate Adjustment / Replacement

Place blocks under the 6-way dozer blade (both sides) to hold the skid plates off the ground.

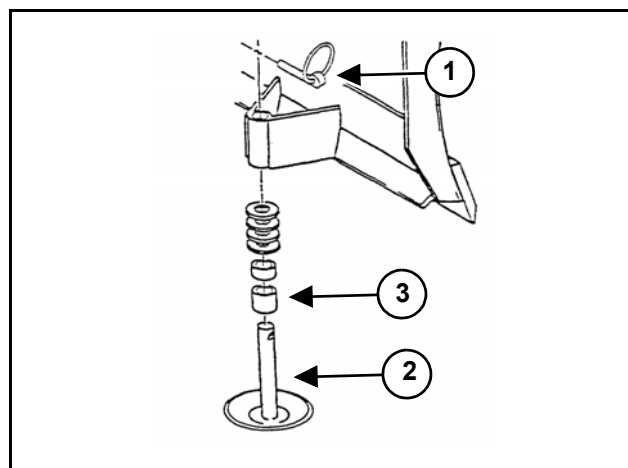

Figure 11

Remove the retaining pin (Item 1) [Figure 11], lower the skid plate, install or remove spacers / washers for desired blade clearance.

Install the skid plate and retaining pin.

Repeat procedures on the opposite side.

NOTE: Skid plates must be set to the same height.

Troubleshooting

PROBLEM	CAUSE	SOLUTION
Dozer blade does not rotate.	No hydraulic flow.	Check quick coupler connections. Engage auxiliary hydraulics.
	Faulty electrical connection.	Check electrical connections.
	Faulty electrical harness.	Repair or replace electrical harness.
	Faulty solenoid.	Replace solenoid.
	Faulty switch.	Replace switch.
	Dozer blade tilt/rotate functions inconsistent.	Hydraulic flow too high.
Dozer blade tilt/rotate functions too slow/fast.	Needle valve setting too low/high.	Adjust needle valve setting.

Storage And Return To Service

Storage

After the seasons use or when the 6-way dozer blade will not be in use for a period of time, perform the following steps.

- Thoroughly wash the 6-way dozer blade.
- Make sure all covers, guards and shields are installed.
- Inspect all components and hardware to ensure everything is secure and thoroughly tightened.
- Inspect the frame and all welds for cracks or damage.
- Lubricate the 6-way dozer blade. (See “Lubrication” on page 32.)
- Apply a light coat of grease to the cylinder rods to prevent rust.
- Inspect the quick-tach mounting frame for wear or damage.
- Inspect decals for missing or damaged decals and reflectors for wear or damage./
- Cap all loose hose ends and electrical connectors.
- Place the 6-way dozer blade in a dry protected shelter.

NOTE: Replace or repair any damaged parts

Return to Service

After the 6-way dozer blade has been in storage, it is necessary to follow a list of items to return the 6-way dozer blade to service.

- Make sure all covers, guards and shields are installed.
- Inspect all components and hardware to ensure everything is secure and thoroughly tightened.
- Lubricate the 6-way dozer blade. (See “Lubrication” on page 32.)
- Inspect the decals and reflectors for missing or damaged parts.
- Install and operate the 6-way dozer blade and check for correct function.
- Check for leaks. Clean and repair as needed.

Skid Plate and Cutting Edge

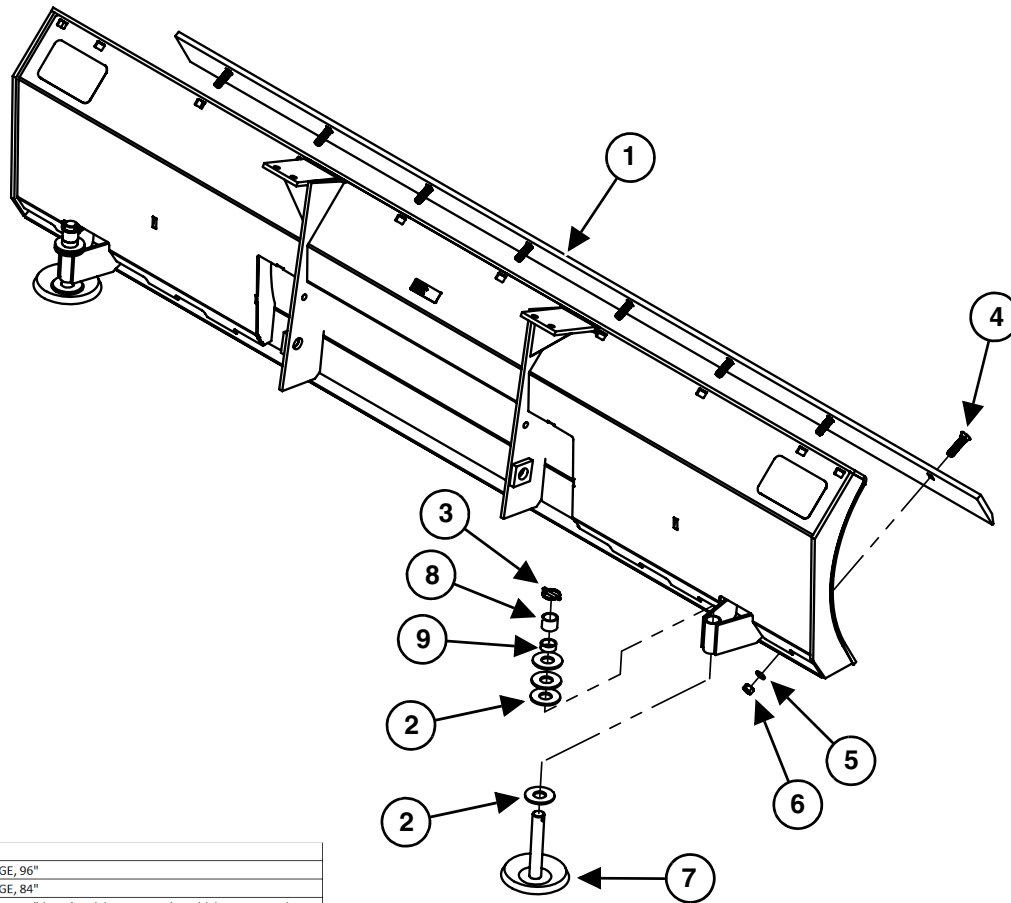

Product Name	Product Description
223230	BLADE, RUBBER CUTTING EDGE, 96"
223220	BLADE, RUBBER CUTTING EDGE, 84"
223215	BLADE, RUBBER CUTTING EDGE, 72" (requires (8) 220650 Bolt and (8) 211016 Nut)
223119	MULTI-PURPOSE BLADE, MINI SERIES, 5' RUBBER CUTTING EDGE WITH HARDWARE
223117	MULTI-PURPOSE BLADE, MINI SERIES, 4' RUBBER CUTTING EDGE WITH HARDWARE
222335	MINI V BLADE 48" CENTER RUBBER CUTTING EDGE

ITEM	DESCRIPTION	PART #	6 FT. QTY	7 FT. QTY	8 FT. QTY
1	CUTTING EDGE, 6' SINGLE BEVEL, 1/2" X 4"	223505	1	-	-
	CUTTING EDGE, 7' SINGLE BEVEL, 1/2" X 4"	223510	-	1	-
	CUTTING EDGE, 8' SINGLE BEVEL, 1/2" X 4"	223515	-	-	1
2	WASHER, FLAT, 1" ZC	223178	8	8	8
3	LYNCH PIN, 1/4" x 1-3/4" #1600	223179	2	2	2
4	BOLT, PLOW 1/2-13 X 2-1/4" ZC	223180	6	7	8
5	WASHER, LOCK, 1/2" ZN	223181	6	7	8
6	NUT, REV LOCK, 1/2-13 UNC HEX GR2 ZC	223182	6	7	8
7	SKID PLATE, WELDMENT	223175	2	2	2
8	BUSHING, 1' x 1"	223176	2	2	2
9	BUSHING, 1' x 1/2"	223177	2	2	2

Blade / Frame Parts

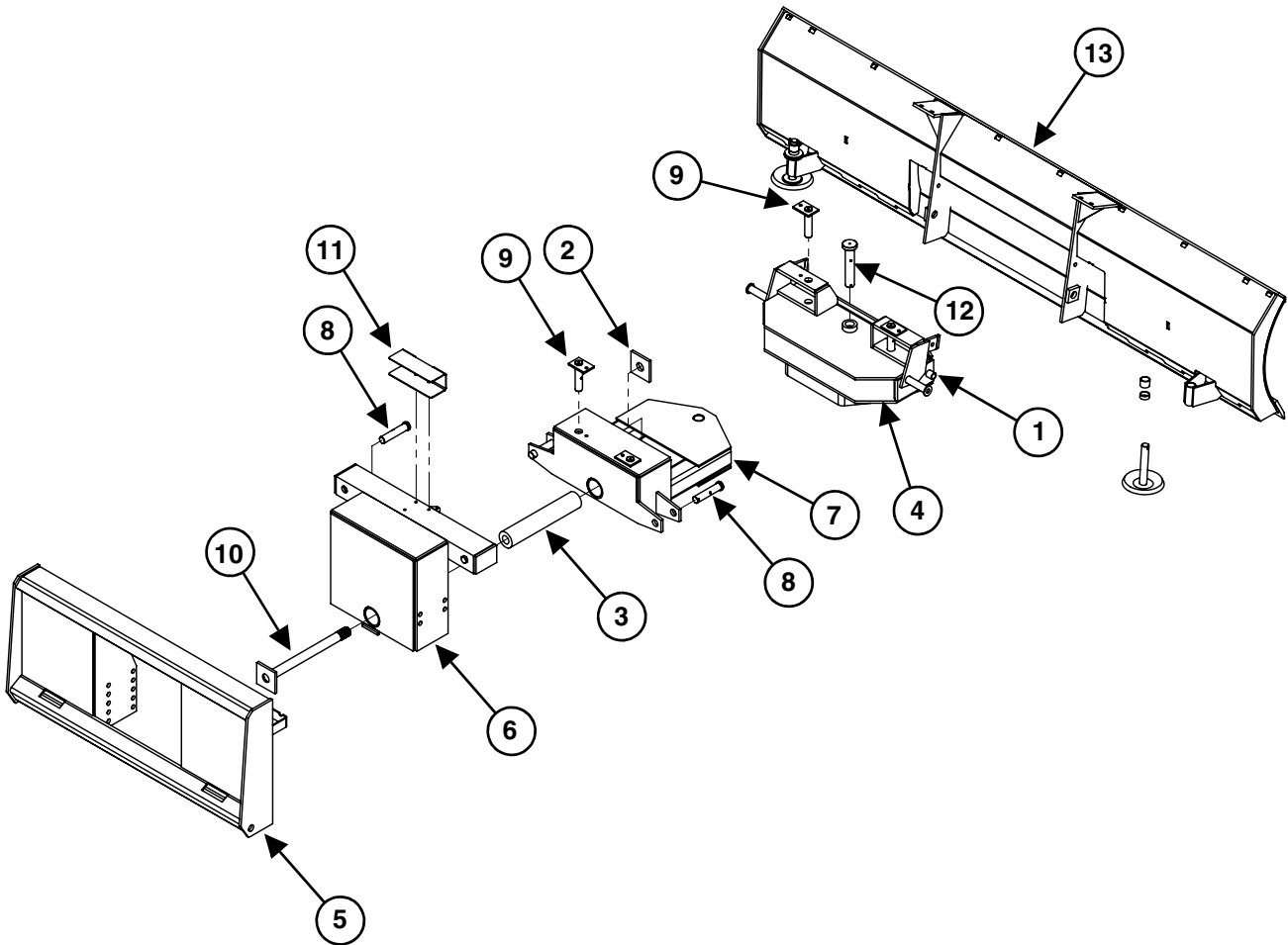

ITEM	DESCRIPTION	PART #	QTY
1	BUSHING	223051	2
2	PLATE	223060	1
3	BUSHING	223061	1
4	PIVOT WELDMENT	223600	1
5	MOUNT WELDMENT HD	223601	1
6	SWIVEL WLDMT, 6-WAY BLADE	223602	1
7	SUBFRAME WELDMT, 6-WAY BLADE	223603	1
8	PIN W/GREASE ZERK	223604	4
9	PIN WELDM'T - CYL	223605	4
10	PIN WELDM'T	223606	1
11	COVER, VALVE BLOCK	223607	1
12	PIN W/ GREASE ZERK	223608	1
13	BLADE WELDMENT, 8' HD W/BACKING	223615	1
	BLADE WELDMENT, 7' HD W/BACKING	223614	1
	BLADE WELDMENT, 6' HD W/BACKING	223613	1

Blade / Frame Hardware

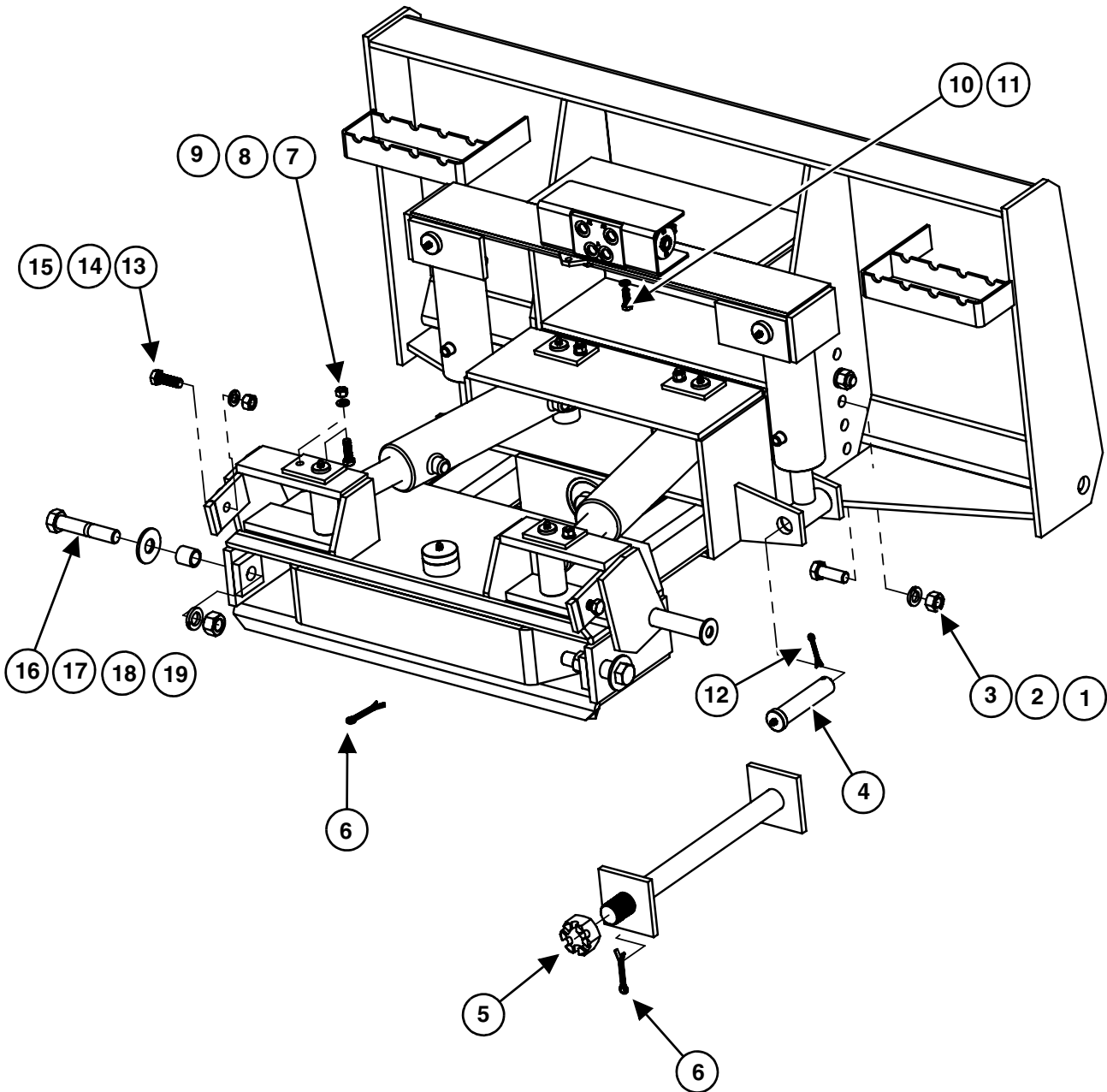

ITEM	DESCRIPTION	PART #	QTY
1	BOLT, 5/8-18 x 1-3/4" HHCS GR 8	103501*	8
2	WASHER, LOCK, 5/8 ZC	100077	8
3	NUT, REV LOCK, 5/8-18 HEX GR2	103502*	8
4	GREASE ZERK, 1/4-28 UNF STRAIGHT	101704	11
5	NUT, SLOTTED HEX, .25-12 - ZINC	102547	1
6	COTTER PIN, 1/4 x 2" ZC 00-250-2	101224	2
7	BOLT, 3/8 - 16 UNC x 1.25" HEX HD ZINC	100046	4
8	WASHER, LOCK, 3/8 ZC	100074	4
9	NUT, 3/8-16 HEX GR 2 ZC	100085	4
10	BOLT, 5/16-18 UNC x 1 HHCS GR5 ZC	100040	2
11	WASHER, 5/16" LOCK ZC	100073	2
12	COTTER PIN, 3/16 x 1-1/2 ZC	100580	4
13	BOLT, 1/2-13 UNC x 1-1/2 HHCS GR5 ZC	100057	2
14	WASHER, LOCK, 1/2" ZN	100076	2
15	NUT, 1/2-13 HEX GR 2- ZC	100087	2
16	BOLT, 3/4-10 x 4" HHCS GR 5 ZC	101330	2
17	WASHER, FLAT, 3/4 ZC	100252	2
18	WASHER, LOCK, 3/4 ZC	100170	2
19	NUT, 3/4-10 HEX GR 2 ZC	100169	2
+ Apply Red threadlocker prior to assembly.			

Hydraulic Valve / Cylinder Plumbing

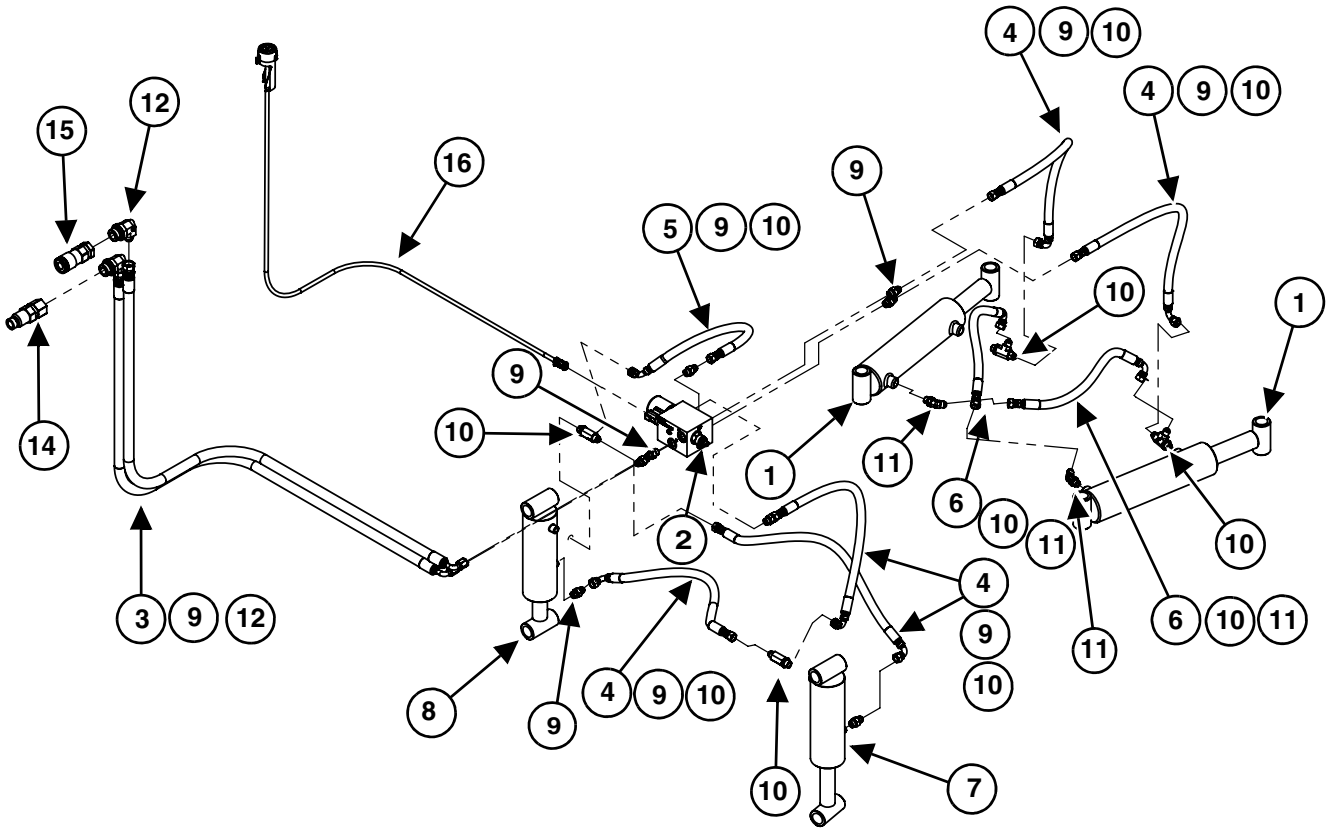

ITEM	DESCRIPTION	PART #	QTY
1	ANGLE CYLINDER	223620	2
	SEAL KIT	223621	1
2	MANIFOLD	223622	1
3	HYD HOSE, 3/8 X 66, 8FJX-6FJX90	223623	2
4	HYD HOSE, 1/4 X 20, 6FJX X 6FJX90	223624	5
5	HYD HOSE, 1/4 X 14, 6FJX X 6FJX90	223625	1
6	HYD HOSE, 1/4 X 12, 6FJX X 6FJX90	223626	2
7	TILT CYLINDER - R.H.	223627	1
	SEAL KIT	223629	1
8	TILT CYLINDER - L.H.	223628	1
	SEAL KIT	223629	1
9	HYD FITTING, 6MJ-6MORB STAIGHT	103443	8
10	HYD FITTING, 6MJ-6MAORB-MJ TEE	103444	4
11	HYD FITTING, 6MJ-6MAORB 45° ELBOW	103445	2
12	HYD. FITTING 8MJ-12MAORB 90 ELBOW	103446	2
13	SLEEVING, NYLON, 1.57 DIA	103449	1
14	1/2 FF QUICK COUPLER - MALE	102434	1
15	1/2 FF QUICK COUPLER - FEMALE	102435	1
16	HARNESS, 6-WAY BLADE SIDE (See options on page 47)	N/A	-
NOTE: If tilt cylinders have NPT ports add and remove the following:			
ADD	HYD FITTING, 6MJ-6FJS-6MJ TEE	103448	4
ADD	HYD FITTING, 6MJ-4MNPT	103447	4
REMOVE	HYD FITTING, 6MJ-6MORB STRAIGHT	103443	2
REMOVE	HYD FITTING, 6MJ-6MAORB-MJ TEE	103444	2

Manifold Assembly

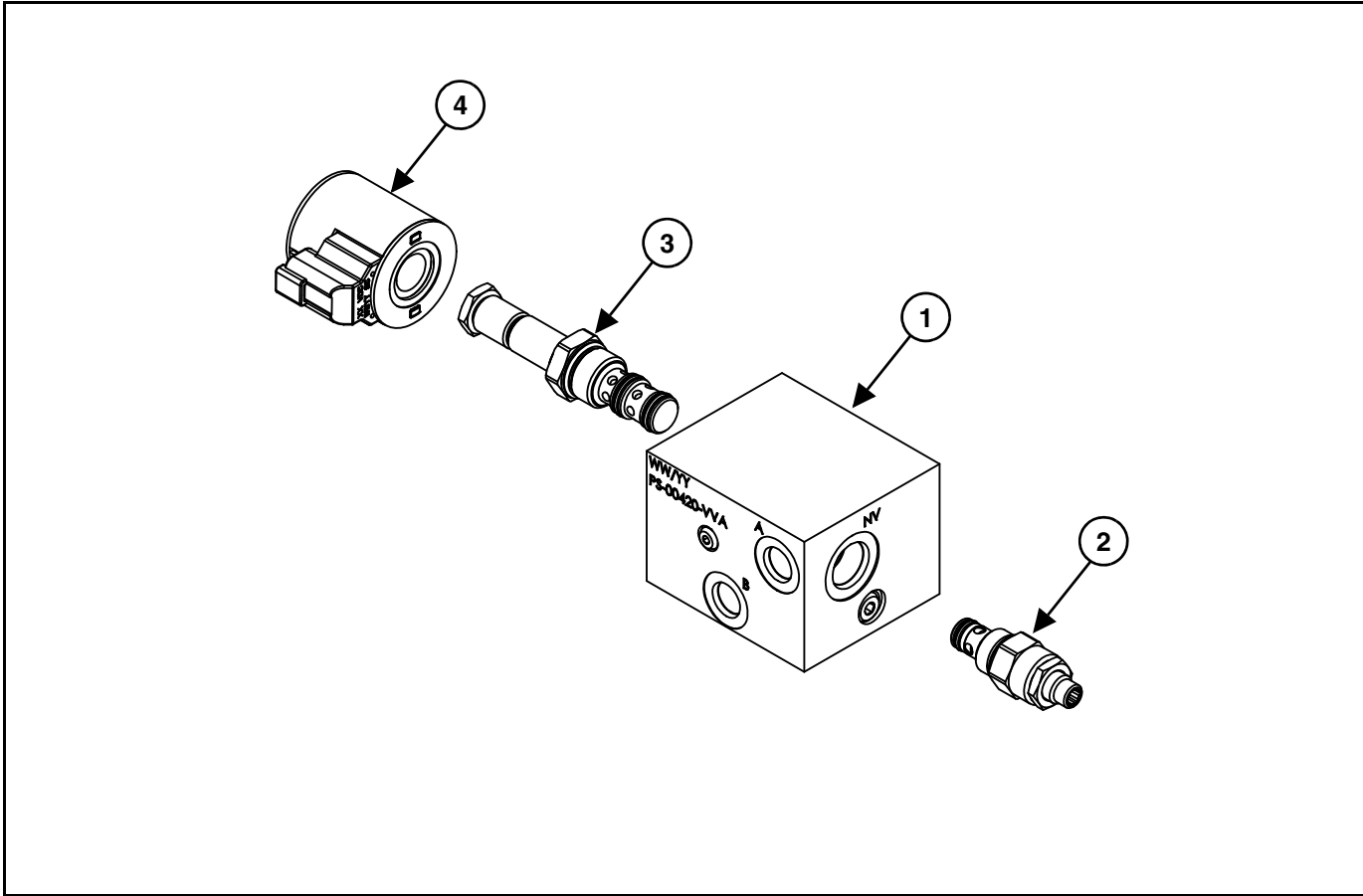

ITEM	DESCRIPTION	PART #	QTY
	MANIFOLD ASSEMBLY (contains items 1 - 4)	223622	1
1	MANIFOLD	103432	1
2	NEEDLE VALVE, #8 CARTRIDGE	103433	1
NOTE:	Rotate the needle valve clockwise to reduce flow. Rotate the needle valve counterclockwise to increase flow.		
3	VALVE, #10 2-POS 3-WAY	103434	1
4	COIL, #10 W/ 2 PIN DEUTSCH	103435	1

Universal Control Kit *(Option)*

This harness kit can be used for the dozer blade, angle broom, pickup broom water kit, and post driver.

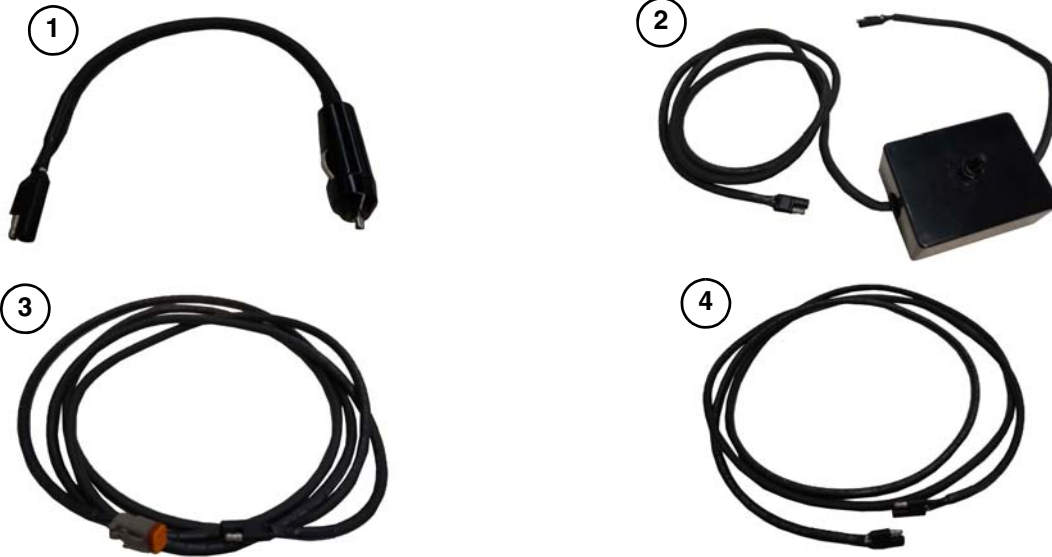

ITEM	DESCRIPTION	PART #	QTY
	UNIVERSAL CONTROL KIT (contains items 1 - 4)	200010	1
1	POWER POINT PLUG WITH 2-PIN TRAILER PLUG	-	1
2	SWITCH BOX WITH WIRES, TRAILER PLUGS EITHER END	-	1
3	9' HARNESS WITH ONE 2-PIN DEUTSCH PLUG AND ONE 2-PIN TRAILER PLUG	-	1
4	9' HARNESS WITH TWO 2-PIN TRAILER PLUGS	-	1

OEM Harness *(Option)*

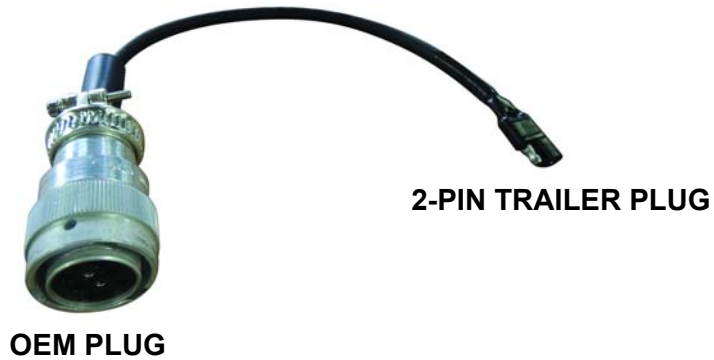

OEM PLUG

2-PIN TRAILER PLUG

DESCRIPTION	PART #	QTY
HARNESS, OEM PLUG 14-PIN (MACHINE SPECIFIC)	216900	1
HARNESS, OEM PLUG 8-PIN (CAT / ASV / TEREX)	217905	1
HARNESS, OEM PLUG, (BOBCAT) (Requires Both) - 7-PIN LOW VOLTAGE	216950	1
	216955	1

NOTE: All OEM Plugs harnesses contain the 2-pin trailer connector.

Trip Springs (Option)

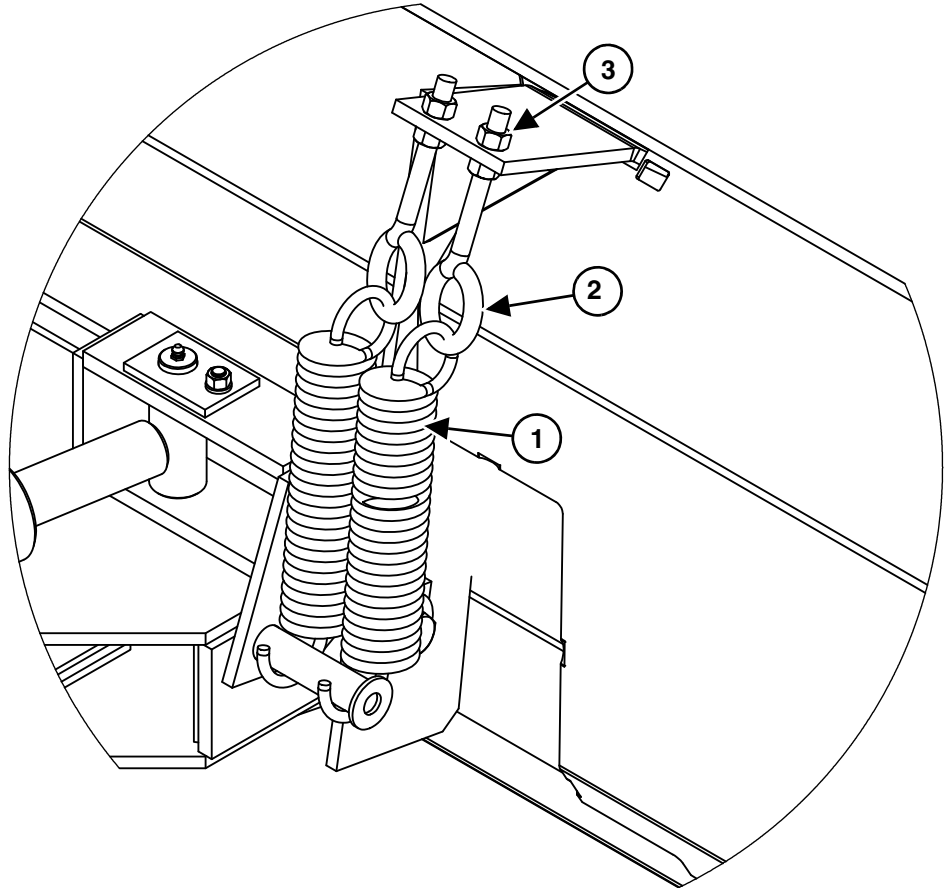

ITEM	DESCRIPTION	PART #	QTY
	TRIP SPRING KIT (contains items 1 - 3)	223700	1
1	TENSION SPRING	100246	4
2	1/2-13 x 6 EYEBOLT	100249	4
3	1/2-13 HEX NUT	100087	8

NOTE: If installing the optional trip springs, items 13, 14, & 15 must be removed. (See page 42).

Blade Extension (Option)

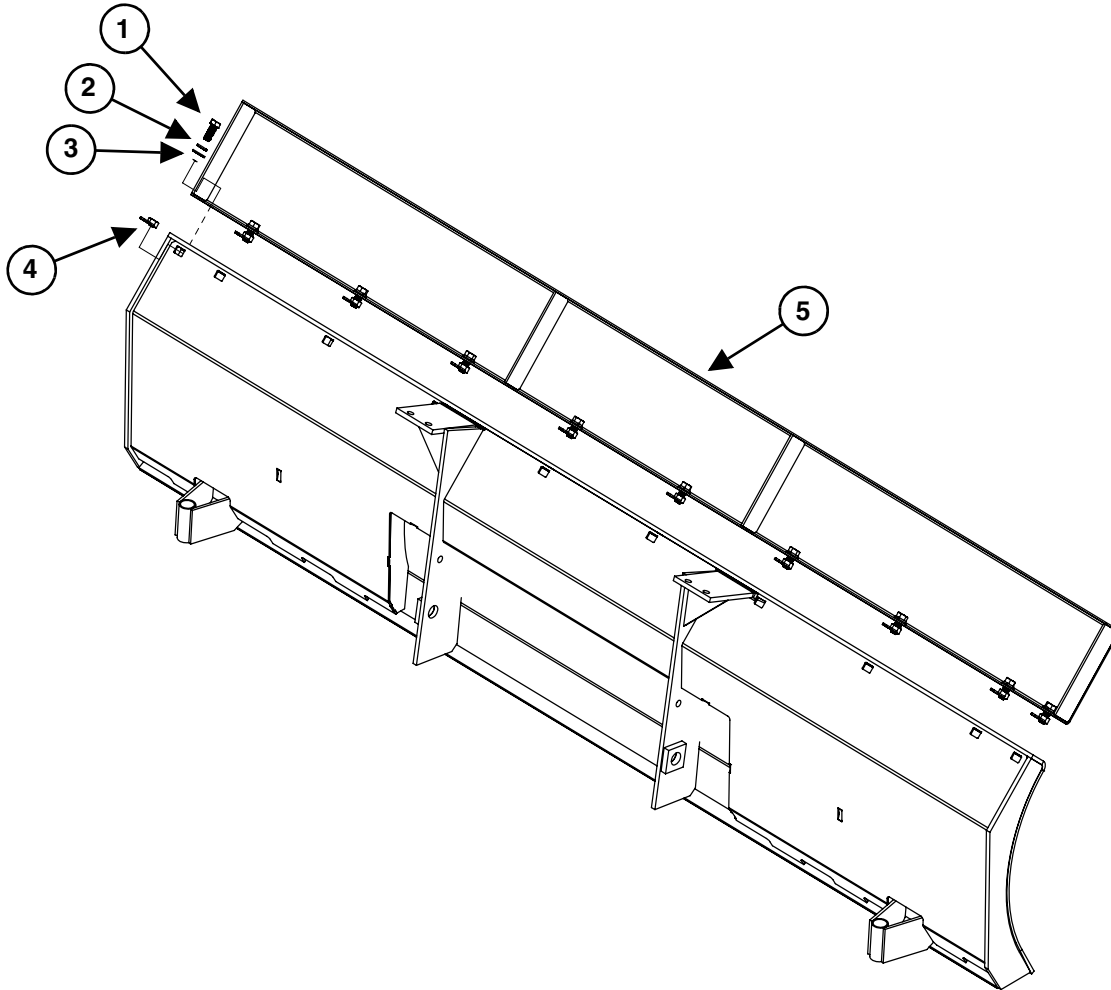

ITEM	DESCRIPTION	PART NUMBER	5 FT. QTY	6 FT. QTY	7 FT. QTY	8 FT. QTY
1	BOLT, 1/2-13 X 1-1/4"	299432	7	8	9	10
2	WASHER, LOCK, 1/2"	299830	7	8	9	10
3	BLADE EXTENSION, WELDMENT 5'	123040	1	-	-	-
	BLADE EXTENSION, WELDMENT 6'	123045	-	1	-	-
	BLADE EXTENSION, WELDMENT 7'	123050	-	-	1	-
	BLADE EXTENSION, WELDMENT 8'	123055	-	-	-	1

Decal Identification And Location

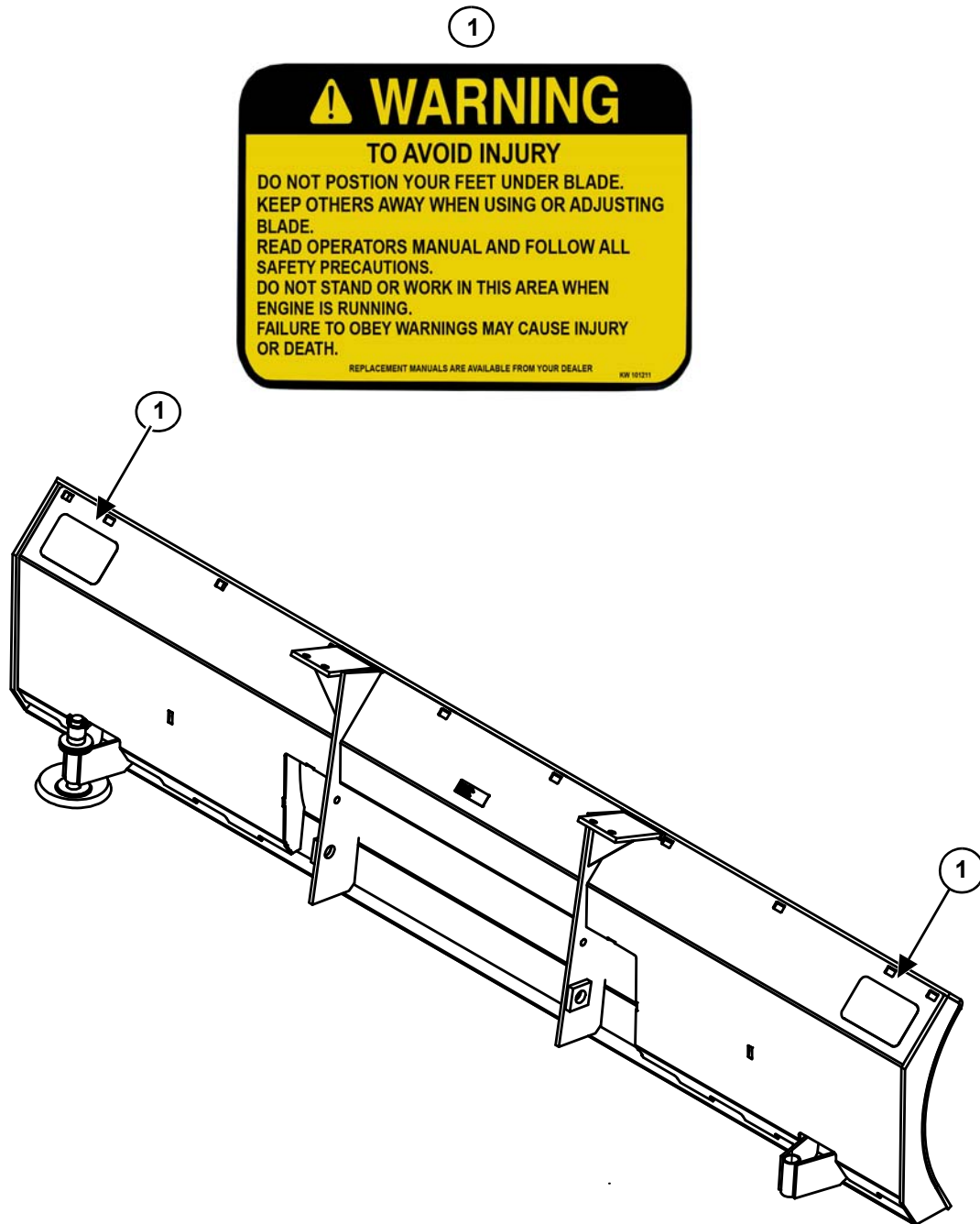

ITEM	DESCRIPTION	PART #	QTY
1	DECAL, WARNING	101211	2

Attachment Specifications

Hydraulic Cylinders (All Models)

DESCRIPTION	TILT	PIVOT
Bore	2-1/2"	2-1/2"
Stroke	4"	8"
Rod Diameter	1-1/4"	1-1/2"

Dimensions

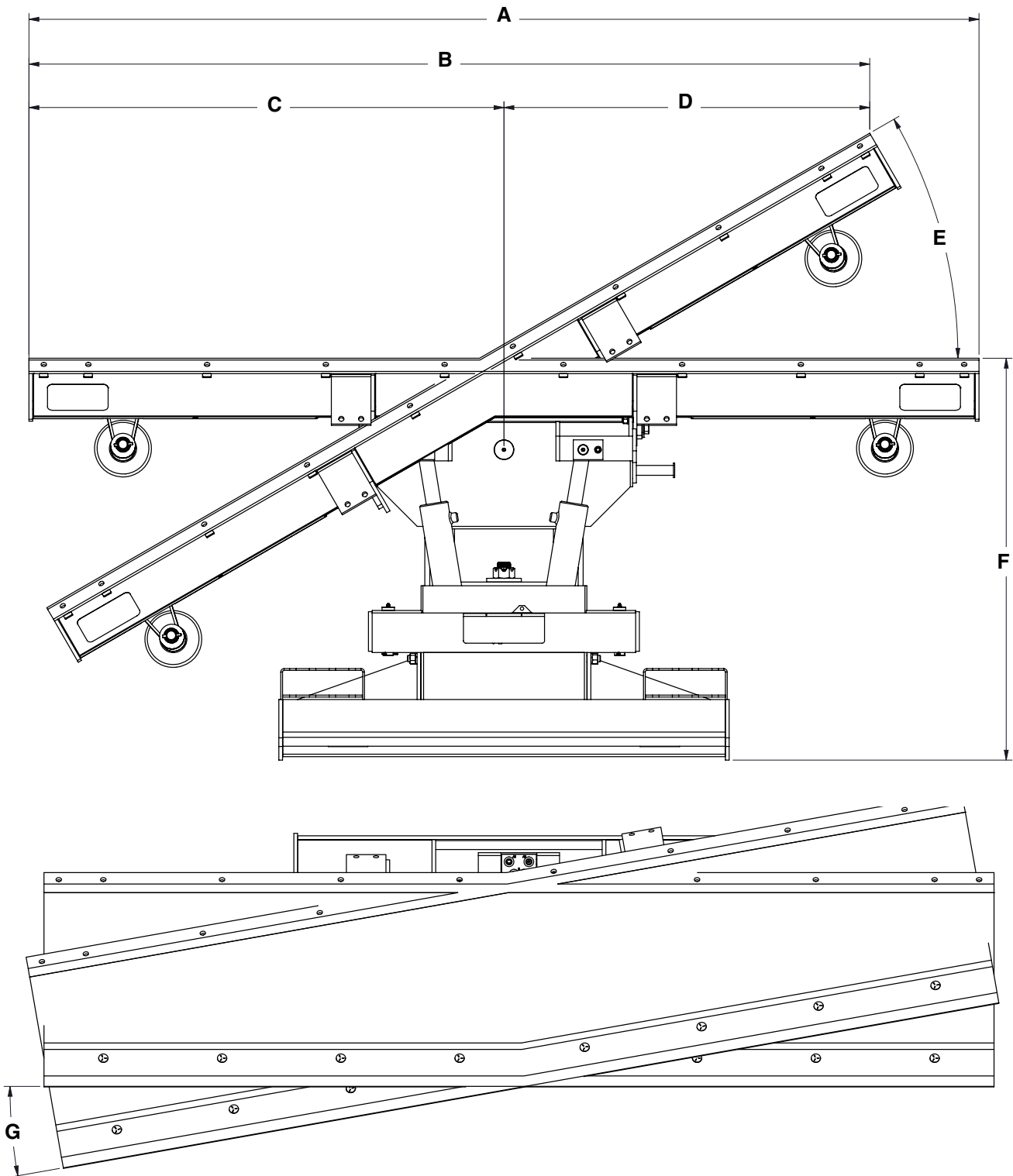

DESCRIPTION	6 FT	7 FT	8 FT
Overall Width (A)	72 in. (1829 mm)	84 in. (2133 mm)	96 in. (2438 mm)
Width at 15° (B)	69-1/2 in. (1765 mm)	81-1/8 in. (2060 mm)	92-3/4 in. (2356 mm)
Width at 30° (C)	62-3/8 in. (1584 mm)	72-3/4 in. (1847 mm)	83-1/8 in. (2111 mm)
Width from Centerline to Inside Edge at 15° (C)	37-1/8 in. (943 mm)	42-7/8 in. (1089 mm)	48-3/4 in. (1238 mm)
Width from Centerline to Inside Edge at 30° (C)	35-3/4 in. (908 mm)	40-7/8 in. (1038 mm)	46-1/8 in. (1172 mm)
Width from Centerline to Outside Edge at 15° (D)	32-3/8 in. (822 mm)	38-1/4 in. (971 mm)	44 in. (1117 mm)
Width from Centerline to Outside Edge at 30° (D)	26-1/2 in. (673 mm)	31-7/8 in. (809 mm)	37 in. (940 mm)
Pivot Angle Left and Right (E)	30°	30°.	30°
Overall Length (F)	40-3/8 in. (1026 mm)	40-3/8 in. (1026 mm)	40-3/8 in. (1026 mm)
Dept of Cut Tilted 10° (G)	6-1/4 in. (159 mm)	7-5/16 in. (186 mm)	8-5/16 in. (211 mm)
Overall Height	22 in. (559 mm)	22 in. (559 mm)	22 in. (559 mm)
Weight	965 lbs. (438 kg)	1015 lbs. (460 kg)	1065 lbs. (483 kg)

Torque Specifications

Standard Hardware And Lock Nuts

BOLT TYPE	SAE GRADE 5		SAE GRADE 8		LOCK NUTS			
	Nominal Size	Plated or Unplated Silver	Plated W / ZnCr Gold	Plated or Unplated Silver	Plated W / ZnCr Gold	Plated or Unplated Silver	Plated W / ZnCr Gold	W / Grade 5 Bolt
1/4	55 in / lb (6.2 N•m)	72 in / lb (8.1 N•m)	86 in / lb (9.7 N•m)	112 in / lb (12.6 N•m)	121 in / lb (13.6 N•m)	157 in / lb (17.7 N•m)	61 in / lb (6.9 N•m)	86 in / lb (9.8 N•m)
5/16	115 in / lb (13 N•m)	149 in / lb (17 N•m)	178 in / lb (20 N•m)	229 in / lb (26 N•m)	250 in / lb (28 N•m)	325 in / lb (37 N•m)	125 in / lb (14 N•m)	176 in / lb (20 N•m)
3/8	17 ft / lb (23 N•m)	22 ft / lb (30 N•m)	26 ft / lb (35 N•m)	34 ft / lb (46 N•m)	37 ft / lb (50 N•m)	48 ft / lb (65 N•m)	19 ft / lb (26 N•m)	26 ft / lb (35 N•m)
7/16	27 ft / lb (37 N•m)	35 ft / lb (47 N•m)	42 ft / lb (57 N•m)	54 ft / lb (73 N•m)	59 ft / lb (80 N•m)	77 ft / lb (104 N•m)	30 ft / lb (41 N•m)	42 ft / lb (57 N•m)
1/2	42 ft / lb (57 N•m)	54 ft / lb (73 N•m)	64 ft / lb (87 N•m)	83 ft / lb (113 N•m)	91 ft / lb (123 N•m)	117 ft / lb (159 N•m)	45 ft / lb (61 N•m)	64 ft / lb (88 N•m)
9/16	60 ft / lb (81 N•m)	77 ft / lb (104 N•m)	92 ft / lb (125 N•m)	120 ft / lb (163 N•m)	130 ft / lb (176 N•m)	169 ft / lb (229 N•m)	65 ft / lb (88 N•m)	92 ft / lb (125 N•m)
5/8	83 ft / lb (112 N•m)	107 ft / lb (145 N•m)	128 ft / lb (174 N•m)	165 ft / lb (224 N•m)	180 ft / lb (244 N•m)	233 ft / lb (316 N•m)	90 ft / lb (122 N•m)	127 ft / lb (172 N•m)
3/4	146 ft / lb (198 N•m)	189 ft / lb (256 N•m)	226 ft / lb (306 N•m)	293 ft / lb (397 N•m)	319 ft / lb (432 N•m)	413 ft / lb (560 N•m)	160 ft / lb (217 N•m)	226 ft / lb (306 N•m)
7/8	142 ft / lb (193 N•m)	183 ft / lb (248 N•m)	365 ft / lb (495 N•m)	473 ft / lb (641 N•m)	515 ft / lb (698 N•m)	667 ft / lb (904 N•m)	258 ft / lb (350 N•m)	364 ft / lb (494 N•m)
1	213 ft / lb (289 N•m)	275 ft / lb (373 N•m)	547 ft / lb (742 N•m)	708 ft / lb (960 N•m)	773 ft / lb (1048 N•m)	1000 ft / lb (1356 N•m)	386 ft / lb (523 N•m)	545 ft / lb (739 N•m)



MANUFACTURER'S LIMITED WARRANTY

BLUE DIAMOND ATTACHMENTS, a manufacturer of quality attachments, warrants new BLUE DIAMOND ATTACHMENTS products and/or attachments at the time of delivery to the original purchaser, to be free from defects in material and workmanship when properly set up and operated in accordance with the recommendations set forth by BLUE DIAMOND ATTACHMENTS, LLC.

BLUE DIAMOND ATTACHMENTS liability for any defect with respect to accepted goods shall be limited to repairing the goods at a BLUE DIAMOND ATTACHMENTS designated location or at an authorized dealer location, or replacing them, as BLUE DIAMOND ATTACHMENTS shall elect. The above shall be in accordance with BLUE DIAMOND ATTACHMENTS warranty adjustment policies. BLUE DIAMOND ATTACHMENTS obligation shall terminate twelve (12) months for the Six Way Dozer Blade after the delivery of the goods to original purchaser.

This warranty shall not apply to any machine or attachment which shall have been repaired or altered outside the BLUE DIAMOND ATTACHMENTS factory or authorized BLUE DIAMOND ATTACHMENTS dealership or in any way so as in BLUE DIAMOND ATTACHMENTS judgment, to affect its stability or reliability, nor which has been subject to misuse, negligence or accident beyond the Company recommended machine rated capacity.

WARRANTY CLAIM

To submit a warranty claim, a return authorization from BLUE DIAMOND ATTACHMENTS must be obtained. The failed part may then be returned. Tampering with the failed part may void the warranty. This warranty does not include freight or delivery charges incurred when returning machinery for servicing. Dealer mileage, service calls, and pickup/delivery charges are the customers' responsibility.

EXCLUSIONS OF WARRANTY

Except as otherwise expressly stated herein, BLUE DIAMOND ATTACHMENTS makes no representation or warranty of any kind, expressed or implied, AND MAKES NO WARRANTY OF MERCHANTABILITY IN RESPECT TO ITS MACHINERY AND/OR ATTACHMENTS ARE FIT FOR ANY PARTICULAR PURPOSE. BLUE DIAMOND ATTACHMENTS shall not be liable for incidental or consequential damages for any breach or warranty, including but not limited to inconvenience, rental of replacement equipment, loss of profits or other commercial loss. Upon purchase, the buyer assumes all liability for all personal injury and property resulting from the handling, possession, or use of the goods by the buyer.

No agent, employee, or representative of BLUE DIAMOND ATTACHMENTS has any authority to bind BLUE DIAMOND ATTACHMENTS to any affirmation, representation, or warranty concerning its machinery and/or attachments except as specifically set forth herein.

This warranty policy supersedes any previous documents.

NOTE: Blue Diamond Attachments is a trademark of BLUE DIAMOND ATTACHMENTS, LLC.



QUALITY | DEPENDABILITY | INTEGRITY

Blue Diamond® Attachments
4512 Anderson Road, Knoxville, TN 37918
888-376-7027