

# Extreme Duty Series 2 Cold Planer 40" & 48"

Operation and Maintenance Manual



160956, 160957

Register your  
**WARRANTY**  
within 30 days  
of purchase



888-376-7027 | [BlueDiamondAttachments.com](http://BlueDiamondAttachments.com)



# Introduction: Owner Information

Thank you for your decision to purchase a Blue Diamond® Extreme Duty Series 2 Cold Planer. To ensure maximum performance of your equipment, it is mandatory that you thoroughly study the Operator's manual and follow the recommendations. Proper operation and maintenance are essential to maximize equipment life and prevent personal injury.

Operate and maintain this equipment in a safe manner and in accordance with all applicable local, state, and federal codes, regulations and /or laws. Follow all on-product labeling and instructions.

Make sure that all personnel have read this Operator's Manual and thoroughly understand safe and correct operating, installation and maintenance procedures.

Blue Diamond® is continually working to improve its products. Blue Diamond® reserves the right to make any improvements or changes as deemed practical and possible without incurring any responsibility or obligation to make any changes or additions to equipment sold previously.

Although great care has been taken to ensure the accuracy of this publication, Blue Diamond® makes no warranty or guarantee of any kind, written or expressed, implied or otherwise with regard to the information contained within this manual. Blue Diamond® assumes no responsibility for any errors that may appear in this manual and shall not be liable under any circumstances for incidental, consequential or punitive damages in connection with, or arising from the use of this manual.

Keep this manual available for frequent reference. All new operators or owners must review the manual before using the equipment and annually thereafter. Contact your Blue Diamond® Attachments Dealer for assistance, information, or additional copies of the manual. Contact [www.bluediamondattachments.com](http://www.bluediamondattachments.com) or call 888-376-7027 for a complete list of dealers in your area.

## Serial Number Location:

Please record attachment information in the space provided for future reference.



Model Number: \_\_\_\_\_

Serial Number: \_\_\_\_\_

Dealer Name: \_\_\_\_\_

Dealer Number: \_\_\_\_\_

Date of Purchase: \_\_\_\_\_

The serial number plate is located on the back right side of the frame as shown above.

Always use your serial number when requesting information or when ordering parts.

**NOTE:** The directions left, right, front, and rear, as mentioned throughout this manual, are as viewed from the operator's position.

# Table of Contents

---

Introduction: <b>Owner Information</b> .....	2	5.8 <b>Spare Parts &amp; Accessories</b> .....	31
1. Introduction.....	4	5.9 <b>Troubleshooting</b> .....	32
1.1 <b>Attachment Identification</b> .....	4	6. Wire Harness Control Guide .....	33
1.2 <b>About this Attachment</b> .....	5	6.1 <b>Warning</b> .....	33
1.3 <b>Attachment Model Numbers</b> .....	5	6.2 <b>Universal Controller</b> .....	33
2. Safety .....	6	6.3 <b>Bobcat</b> .....	34
2.1 <b>General Safety Information</b> .....	6	6.4 <b>CASE &amp; New Holland</b> .....	34
2.2 <b>Operators</b> .....	7	6.5 <b>CAT D XPS / XHP</b> .....	35
2.3 <b>Safety Guidelines</b> .....	8	6.6 <b>CAT D3 XPS / XHP X XE</b> .....	35
3. Transport.....	11	6.7 <b>Gehl / Manitou / Mustang</b> .....	36
3.1 <b>Delivering &amp; Unloading</b> .....	11	6.8 <b>JCB / Volvo — Post 10 / 2010</b> .....	36
3.2 <b>Handling, Transportation, &amp; Lifting</b> .....	11	6.9 <b>JCB / Volvo — New Series 3.x</b> .....	37
4. Use.....	13	6.10 <b>John Deere</b> .....	37
4.1 <b>Preliminary Checks</b> .....	13	6.11 <b>Kubota</b> .....	38
4.2 <b>How to Enter &amp; Exit the Skid Steer</b> .....	13	6.12 <b>Takeuchi</b> .....	38
4.3 <b>Attachment Installation</b> .....	14	6.13 <b>Wacker Neuson</b> .....	39
4.4 <b>Connecting Hydraulic Hoses</b> .....	15	6.14 <b>Yanmar</b> .....	39
4.5 <b>Connecting Quick Couplers</b> .....	16	7. Parts .....	40
4.6 <b>Disengaging Hydraulic Hoses</b> .....	16	7.1 <b>Main Components – Both Models</b> .....	40
4.7 <b>Disconnecting Attachment from Machine</b> .....	17	7.2 <b>Frame Components – Both Models</b> .....	42
4.8 <b>Pre–Operation</b> .....	18	7.3 <b>40” Depth Components</b> .....	43
4.9 <b>Preparing the Equipment for Use</b> .....	18	7.4 <b>48” Depth Components</b> .....	45
4.10 <b>Sideshift Function</b> .....	19	7.5 <b>48” Tilting Components</b> .....	47
4.11 <b>Floating Tilt Function</b> .....	19	7.6 <b>Drum Components – Both Models</b> .....	48
4.12 <b>Planing Depth</b> .....	20	7.7 <b>Left Side Mount Components – Both Models</b> .....	49
4.13 <b>Operating Procedure</b> .....	21	7.8 <b>Motor Components</b> .....	50
4.14 <b>Planing in Parallel Passes</b> .....	22	7.9 <b>Sideshift Components – Both Models</b> .....	51
4.15 <b>Water Spraying Unit (Optional)</b> .....	23	7.10 <b>Machine Hoses Left Side – Both Models</b> .....	52
4.16 <b>Stopping the Equipment in Normal Conditions</b> .....	23	7.11 <b>G4 Block Components – Both Models</b> .....	53
4.17 <b>Emergency Stops</b> .....	23	7.12 <b>Hydraulic Motor Components – Both Models</b> .....	55
4.18 <b>Parking</b> .....	24	7.13 <b>Hydraulic Sideshift Components – Both Models</b> .....	57
4.19 <b>Preparing the Unit for Long Periods of Inactivity</b> .....	24	7.14 <b>40” Water Kit Components</b> .....	58
4.20 <b>Recommissioning the Unit after Long Periods of Inactivity</b> .....	24	7.13 <b>24” Tool Kit</b> .....	60
4.21 <b>Disposal</b> .....	24	7.15 <b>Safety Decals</b> .....	61
5. Maintenance.....	25	8. Specifications .....	63
5.1 <b>Service Schedule</b> .....	25	8.1 <b>Attachment Specifications</b> .....	63
5.2 <b>Every Hour</b> .....	26	8.2 <b>Torque Specifications</b> .....	66
5.3 <b>Every 8 Hours</b> .....	28	Warranty.....	69
5.4 <b>Every 50 Hours</b> .....	29		
5.5 <b>Every 100 Hours</b> .....	29		
5.6 <b>Every 200 Hours</b> .....	30		
5.7 <b>When Required</b> .....	30		

# 1. Introduction

## 1.1 Attachment Identification

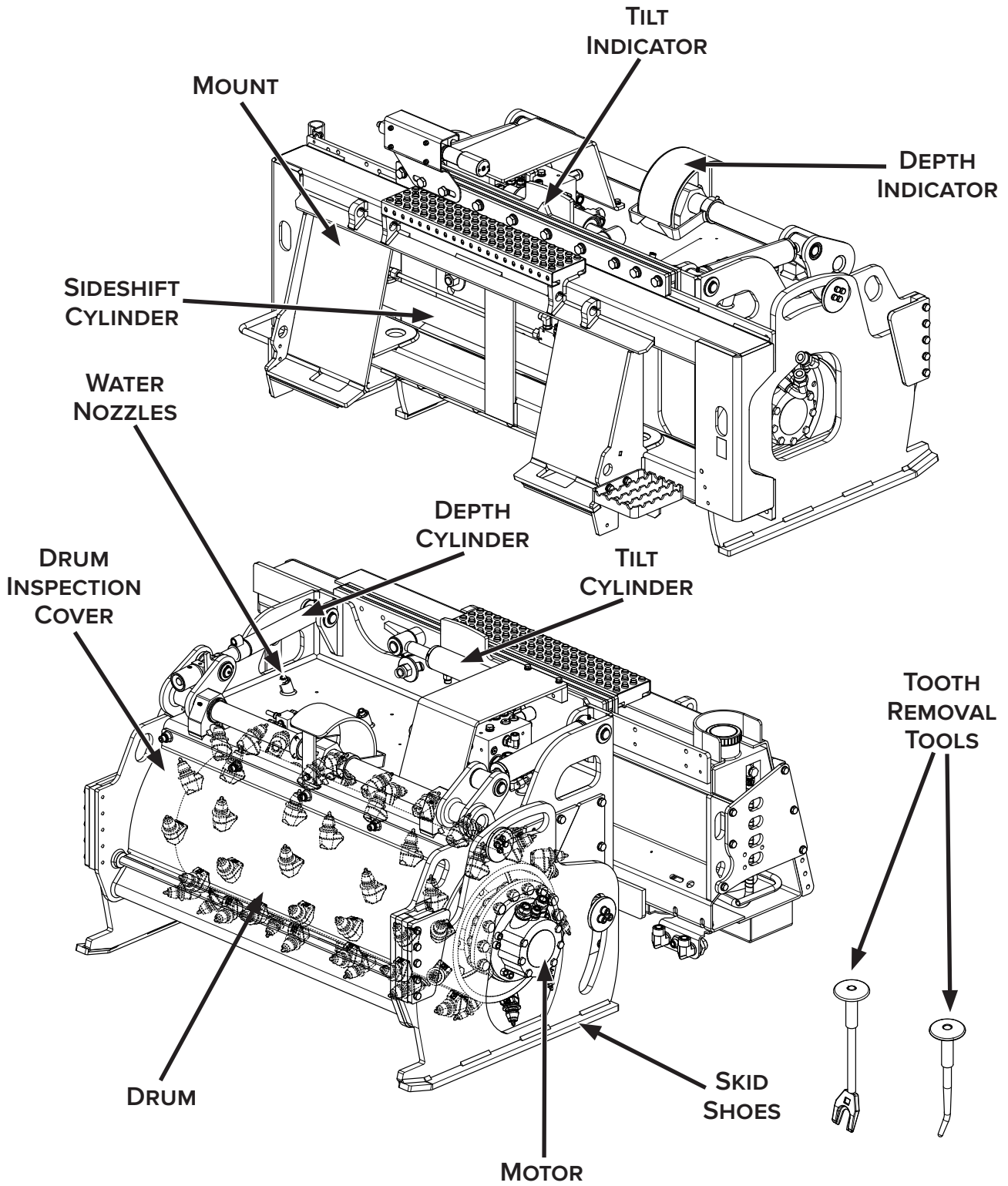

# 1. Introduction

## 1.2 About this Attachment

### Intended Use

The Extreme Duty Series 2 Cold Planer is designed to be connected to a skid steer to perform variable depth scarification works of hard and compact materials, such as asphalt, rock, concrete, and sediments.

The Extreme Duty Series 2 Cold Planer can self-level for variable depth planing for asphalt, rock, concrete, sediment, gravel, etc. This attachment's drum rotates and cuts material from the bottom upwards, crushing and removing it with the hard, metal teeth located on its outer surface. The drum rotation is driven by a fixed displacement hydraulic motor that is directly connected and powered by the machine, such as a skid steer, through hoses and quick couplers.

The skid shoes hold the planed material. They rest on the ground and are held in place by two (2) independently controlled hydraulic cylinders. These determine the planing depth and allow for different setting on the left and right side.

To facilitate planing on a surface that is not parallel to the surface the host machine's wheels are resting on, the attachment tilts to follow the contour of the planing space.

The crushed material is left on the ground.

The attachment can be shifted to the right to plane up to and beyond the edge of the host machine.

An optional water spraying system, which can be fitted with the tank and electric pump mounted on the prime mover, sprays water towards the teeth of the drum. This significantly reduces the dust produced during planing.

The attachment is mounted solidly onto the machine with a universal skid steer mount. The hydraulic power is also supplied by the machine, and the connections used are hydraulic quick couplers.

All functions of the attachment are controlled by the existing controls on the machine, sometimes with the addition of a specific control panel, but this is also installed on the machine and not the cold planer.

The forward movement is provided by the machine.

Operate the attachment with the skid shoes placed on firm and stable on the ground; for safety reasons, keep the front of the host machine raised a couple inches from the ground.

## 1.3 Attachment Model Numbers

MODEL NUMBER	CUTTING WIDTH
160956	40"
160957	48"

## 2. Safety

### 2.1 General Safety Information



This **SAFETY ALERT SYMBOL** identifies important safety messages on the equipment and in the owner's manual. When you see this symbol, be alert to the possibility of personal injury and carefully read the message that follows.



The signal word **IMPORTANT** identifies procedures which must be followed to avoid damage to the machine.



The signal word **DANGER** on the machine and in the manuals indicates a hazardous situation which, if not avoided, will result in death or serious injury.



The signal word **WARNING** on the machine and in the manuals indicates a potentially hazardous situation which, if not avoided, could result in death or serious injury.



The signal word **CAUTION** on the machine and in the manuals indicates a potentially hazardous situation which, if not avoided, may result in minor or moderate injury. It may also be used to alert against unsafe practices.

**NOTE:** Notes are used to indicate important information. This information may be repeated in other areas of the manual.

### Operating Safety

- Read and follow instructions in this manual and the machine's Operator's Manual before operating.
- The manual must always remain with the machine. In case of loss or damage, request a new copy from your dealer or from Blue Diamond®.
- Strictly follow all rules prescribed by the safety pictograms/decals applied to the machine. Ensure that all safety pictograms/decals are legible. If pictograms/decals are worn, they must be replaced with new ones obtained from Blue Diamond® and placed in the position indicated by this manual.
- Before using the machine, make sure that all safety devices are installed and in good working condition. In case of damaged or missing shields, replace them immediately.
- It is absolutely forbidden to remove or alter safety devices and/or safety precautions.
- If the use of the machine is required at night or in conditions of reduced visibility, the work area must be illuminated (200 lux) by use of the host machine or fixed/immobile auxiliary lighting.



Improper use and maintenance operations can cause serious injury and shorten the useful lifetime of the machines.

The operator and qualified technicians must have thorough knowledge of all requirements listed in this manual before beginning to use the machine or perform maintenance operations.

The procedures contained in this manual shall be understood to apply to the machines only where used for the permitted purposes and with all safety devices and equipment installed and operational; if the machines are used for other purposes or under different safety situations, the customer shall bear direct responsibility for persons involved in accidents or incidents and any unusual wear to the equipments.

## 2. Safety

### 2.1 General Safety Information

#### Cont'd

#### Operating Safety Cont'd

- Pay maximum attention to avoid any accidental contact with rotating parts of the machine.

### 2.2 Operators

#### Qualified Operators

The operator is a person suited to the work and who is physically and psychologically able to withstand the demands connected with operating the equipment for its intended use. The operator must not allow anyone to approach the machine while it is working and must not allow external personnel to operate the machine or attachment.

The operator is to follow the given instructions in this manual and the machine operator's manual in order to obtain maximum performance, minimal fuel consumption, and maximum safety for himself and for others.

The operator is responsible for scrupulously observing all the instructions given in this manual.



**DANGER**



#### **AVOID SERIOUS INJURY OR DEATH**

Operators must receive instructions before operating the machine. Untrained operators can cause serious injury or death.

For an operator to be qualified, he or she must not use drugs or alcoholic drinks which impair alertness or coordination while working. An operator who is taking prescription drugs must get medical advice to determine if he or she can safely operate a machine and the equipment. For an operator to be qualified, he or she must have read and understood the instructions of this manual, he or she must make adequate preparation for the proper use of the machine, and he or she must hold a driving license.

In case of doubt regarding the use of the machine and/or the interpretation of this manual, the operator must contact either their dealer or Blue Diamond®.

#### Operator Training

- Check the rules and regulations at your location. The rules may include an employer's work safety requirements. Regulations may apply to local driving requirements or use of a Slow Moving Vehicle (SMV) emblem. Regulations may identify a hazard such as a utility line.
- The new operator must start in an area without bystanders and use all the controls until he or she can operate the machine safely under all conditions of the work area.

#### Operator Safety

- Before starting, and during operation of the attachment, make sure there are no people or animals in the operation area.
- During operation, adjustment, maintenance, repairing, or transportation of the machine, the operator must always use appropriate Personal Protective Equipment (PPE) including but not limited to safety glasses, working gloves, dust mask, safety helmet, and hearing protection.
- DO NOT operate the attachment or machine while wearing loose fitting clothing that can be entangled or caught in parts of the machine.
- DO NOT operate the implement when tired, not in good condition, or under the influence of alcohol or drugs.
- Any use of the equipment which does not comply with the uses specified in this operation and maintenance manual is strictly prohibited.
- DO NOT stand, move, or work on floors or any non-bearing structures.
- DO NOT use the equipment for planing at levels higher than the host machine shifting level.
- DO NOT work in dangerous weather conditions (i.e. lightning).
- Make sure the machine being used has all the dead-man's controls fitted and that they are in perfect working order.
- Ensure that normal maintenance has been performed.

## 2. Safety

---

### 2.3 Safety Guidelines

#### Operating Safety

- Read and follow instructions in this manual and the machine's Operator's Manual before operating.
- Check that the attachment has not suffered any damage during transportation. If so, immediately contact Blue Diamond® Product Support.
- Under NO circumstances should young children be allowed to work with this equipment.
- This equipment is dangerous to persons unfamiliar with its operation.
- Check for overhead and/or underground lines before operating equipment (if applicable).
- In addition to the design and configuration of equipment, hazard control and accident prevention are dependent upon the awareness, concern, prudence, and proper training of personnel involved in the operation, transport, maintenance, and storage of equipment.
- Check that the attachment is securely fastened to the machine.
- Make sure all the machine controls are in the NEUTRAL before starting the machine.
- Operate the equipment only from the operator's position.
- Operate the equipment according to the Operator's Manual.
- When learning to operate the equipment, do it at a slow rate in an area clear of bystanders.
- DO NOT permit personnel to be in the work area when operating the equipment.
- The attachment must be used ONLY on approved machines.
- DO NOT modify the equipment in any way. Unauthorized modification may impair the function and/or safety and could affect the life of the equipment.
- No modifications may be made to the equipment or its components without written authorization from Blue Diamond®. Unauthorized modifications may alter the design parameters for the original performance of the equipment, resulting in the termination of any and all warranties as well as civil and/or criminal responsibility for damage or injuries.
- DO NOT make any adjustments or repairs on the equipment while the machine is running.
- Keep shields and guards in place. Replace if damaged.
- DO NOT operate equipment in poor visibility conditions such as fog, darkness, or any conditions that limit clear visibility less than 30 feet (10 m) in front of and to the sides of the equipment.
- When conditions make it necessary to slow ground speed, shift to a lower gear rather than reducing engine speed. The engine will maintain rated speed and keep the cold planer running at optimum milling speed.
- DO NOT operate in a work area that has not been inspected for foreign debris and obstacles.
- Remove any foreign objects and clearly mark any objects that cannot be removed.
- Wear safety glasses, gloves, hearing protection, and other protective clothing when required.
- Only use spare parts supplied by Blue Diamond®, as they offer functional and durability as well as easy interchangeability.
- Any repairs needed must be carried out solely by authorized personnel, using original spare parts. If this rule is not applied, the user could be exposed to serious risks.
- The host machine must NEVER be moved sideways when the drum is in use.
- DO NOT leave the equipment installed on the machine unattended in the work area.



## 2. Safety

---

### 2.3 Safety Guidelines Cont'd

#### Machine Requirements and Capabilities

- The machine's operator's cab should be equipped with a thermoplastic polycarbonate or similar material front window, and similar protection on the sides of the operator's cab before operating the equipment.
- Keep bystanders clear of moving parts and the work area. Keep children away.
- Use caution on slopes and near banks and ditches to prevent overturn.

#### Residual Risks

- When the equipment is in use, the following risks may arise:
  - Electric shocks from contact with underground power lines.
  - Fire and explosions through contact with underground gas lines.
- Anyone standing in the vicinity of the equipment may be exposed to the following risks:
  - Risks originating from blows, catching, or shearing as result of accidental contact with the rotating drum.
  - Risk of crushing between the equipment and the prime mover.
  - Risk of rubble (stones, blunt objects, etc.) being thrown out.
  - Risk of falling spoil (when working on uneven ground or on surfaces at different heights).

#### Environmental Conditions

- With working temperatures below 14°F (-10°C), let the skid steer loader idle before beginning work, and when the hydraulic circuit exceeds 32°F (0°C), run the machine until the working temperature has been reached.
- The work area must comply with the regulations in force concerning hygiene and safety in the workplace.

- If the equipment is required to be partially immersed in saline environments, contact Blue Diamond® Product Support.
- No naked flames and such near the equipment.
- DO NOT use the equipment in environments where there is a risk of explosion or fire.

#### Fire Prevention Safety

- Flammable debris (leaves, grass, etc.) must be removed regularly. If flammable debris is allowed to accumulate, it can cause a fire hazard. Clean often to avoid this accumulation.
- The equipment's hydraulic motor compartment must be inspected every day and cleaned if necessary to prevent fire hazards and overheating.
- All fuels, most lubricants, and some coolant mixtures are flammable. Flammable fluids that are leaking or spilled onto hot surfaces or onto electrical components can cause a fire.

#### Transporting Safety

- Comply with federal, state, and local laws governing highway safety and movement of machinery on public roads.
- Check local laws for all highway lighting and marking requirements.
- Always yield to oncoming traffic, and move to the side of the road so any following traffic may pass.
- Never allow riders on either machine or equipment.
- If transporting the equipment on a truck or trailer, make sure the equipment is properly secured to the transport vehicle.
- Machines with attachments installed have a different center of gravity and overall dimensions.

## 2. Safety

### 2.3 Safety Guidelines Cont'd

#### Transporting Safety Cont'd

- The operator must take great care during movements and maneuvers, avoiding dangerous imbalances and proceeding at low speeds at all times. Keep the attachment raised a couple inches or a few centimeters from the ground.
- It is mandatory to remove the attachment from the prime mover when driving on public roads unless the prime mover's vehicle registration and road-worthiness approval have been updated specifically.
- Blue Diamond® shall not be held responsible for either criminal or civil consequences deriving from failure to obey or abuse of these requirements and limitations.

#### Hydraulic System

- Ensure that the hoses are sufficient to resist the auxiliary pressure of the host machine and that the hoses and connectors are correctly connected.
- All inspections of the hoses and fittings must be carried out using suitable personal protective equipment (PPE).
- Check hydraulic tubes, hoses, and fittings for damage and leakage. Never use open flame or bare skin to check for leaks. Hydraulic tubes and hoses must be properly routed and have adequate support and secure clamps. Tighten or replace any parts that show leakage.
- Always clean fluid spills. DO NOT use gasoline or diesel fuel for cleaning parts. Use commercial nonflammable solvents.

#### Safety Devices

- The safety tools must NEVER be tampered with.
- The equipment must NEVER be used without the safety guards fitted.
- Always use the appropriate personal protective equipment (PPE) when performing any type of maintenance.
- The tools can reach high temperatures during work; it is therefore necessary to wait for them to cool and use appropriate gloves if it is likely to come into contact with them.

#### Personal Protective Equipment



**Proper Work Clothes:** To help ensure your safety as a designated operator wear proper work clothes including tight fitting clothes, protective gloves and shoes.



**Hand Protection:** To help ensure your safety as a designated operator wear protective gloves.



**Protective Shoes:** To help ensure your safety as a designated operator wear protective shoes.



**Safety Helmet:** To help ensure your safety as a designated operator wear a safety helmet.



**Safety Helmet and Eye/Ear Protection:** To help ensure your safety as a designated operator wear a safety helmet and eye/ear protection.

## 3. Transport

### 3.1 Delivering & Unloading

The Extreme Duty Series 2 Cold Planer is normally transported and delivered securely, fastened to a pallet in a stable position and wrapped in plastic sheeting. The type of packing may vary according to the desired means of transport and destination.

#### **IMPORTANT**

- Any optional materials (spare teeth, adapter plate, connecting hoses, keys for teeth replacement, etc.) are contained in a separate package.
- Upon receiving the attachment, check it for any damage (major breakages or dents) caused during transportation. If any are found, the carrier must be alerted immediately and the statement “Accepted Conditionally” must be added to the delivery note.
- In the event of damage, give notice of the fact to the carrier in writing within eight (8) days of the receipt of the equipment.
- If, upon delivery, major damage caused during transportation is noted or any parts that should be included are found to be missing, Blue Diamond® Product Support must be promptly notified of the situation.
- It is also essential to check the equipment delivered against the information given in the itemized shipping document.

#### **WARNING**

- The packed unit must be unloaded with the utmost care using lifting equipment with a suitable capacity (e.g. fork lift or other appropriate means).
- The entire unit must be placed on a flat, stable surface.
- All load handling operations must be carried out by qualified personnel in compliance with regulations in force concerning safety in the workplace.
- Dispose of the packing in compliance with the regulations in force in the country of use.

### 3.2 Handling, Transportation, & Lifting



#### **WARNING**



- If the approval of the skid steer/host machine to travel on normal roads does not extend to the attachment, it must be removed before transportation on open roads.
- Only small movements may be performed on the worksite when the attachment is mounted on the prime mover; during these movements, shifting must be carried out at low speeds with the attachment close to the ground with the prime mover arms. All personnel, bystanders, etc. must be kept at a safe distance away.
- The attachment must always be removed from the prime mover before the vehicle is driven up loading ramps.
- The attachment must NOT be operated during handling.

#### **Handling Over Short Stretches (In the Workplace)**

- Use the skid steer, leaving the cold planer attached.
- Secure the equipment to the pallet, and handle it with a forklift or a transpallet.

#### **Handling Over Long Stretches**

- Secure the equipment to a pallet, using a forklift or a transpallet for handling, then load it onto the method of transportation.

## 3. Transport

### 3.2 Handling, Transportation, & Lifting Cont'd

#### Lifting from One Surface to Another (e.g. to Load onto a Truck)

- Use a lifting crane or truck with a suitable capacity for the weight specified on the serial plate. Connect the cables or chains at the two (2) points shown with the relative stickers. When lifting, use hooks or straps capable holding the cold planer's weight.



#### WARNING



- Check that the capabilities of the cables, chains, and lifting and transportation method in general are compatible with the attachment weight specified on the serial plate.
- Keep the attachment close to ground (safe height of 1.5 ft. or 0.5 m) when moving with it attached to the skid steer.
- Shifting is only permitted on flat or slightly loose ground as long as stability is never jeopardized.
- Check that the pallet on which it will be stored is in suitable condition.

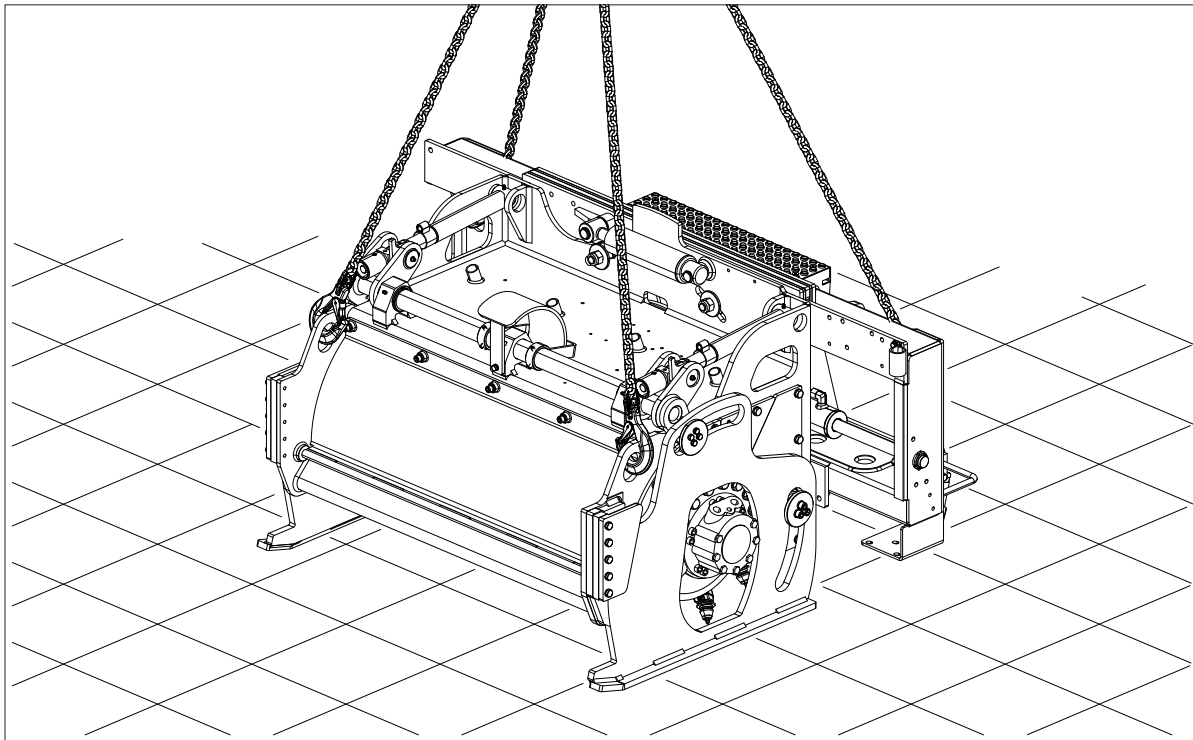

Figure 1

## 4. Use



### WARNING



- The operator is responsible for checking that the machine meets the attachment specifications.
- The attachment may only be fitted onto machines that are equipped with safety systems that disable the machine's controls when there is no one in the operator's position.



### WARNING



- Before starting, the operator must perform some simulated maneuvers to gain confidence with the equipment. This must be performed in a restricted area where bystanders are kept clear. The operator must practice until he or she is confident under any working condition.
- Be careful when passing near open excavations, slopes, and verges.

### 4.1 Preliminary Checks

Before proceeding with the connection to the attachment, the machine being used must undergo checks:

1. Check that all safety and braking devices (parking brakes) are in working order.
2. Check that all the quick couplers (when featured) on the machine, attachment, and other components related to the coupling system are in good condition.



### WARNING



Machines with the attachment installed have a shifted center of gravity, weight, etc. and take up more space than the machine by itself. Be careful when moving, and proceed at a low speed, avoiding any sudden movement that can result in significant and dangerous variations in the machine stability or balance.



### WARNING



- Always ensure that there are three (3) points of contact (grip or support) when getting in and out of the machine to ensure balance is maintained in order to not fall.
- The foot CANNOT be resting on the surface of the structure marked with the "Rotating Drum" sticker (See "7.15 Safety Decals" on page 61).

### How to Enter

1. Rest the left foot on the lower step [Figure 2, Item 1] of the attachment.
2. Shift the weight on the left foot, and then raise the right foot onto the upper step [Item 2] of the equipment.
3. Put the weight on your right foot, then raise your left foot onto anti-slip step [Item 3] of the host machine.

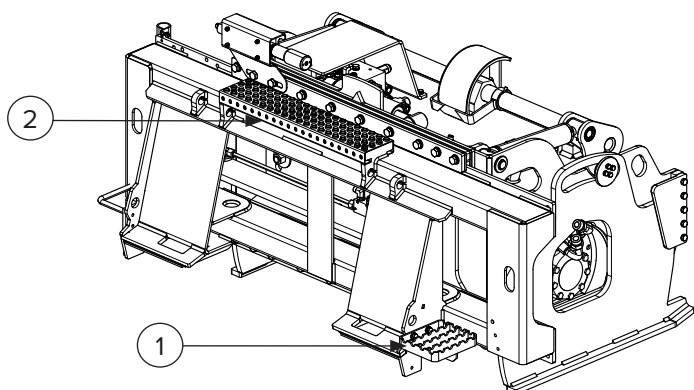

Figure 2

## 4. Use

### 4.2 How to Enter & Exit the Skid Steer Cont'd

#### How to Exit

Reverse the steps of “How to Enter”.

If the lower step is installed on the equipment’s left side, get on and off the equipment as instructed above with the foot motion in reverse.



#### WARNING



- Always use the anti-slip steps to get in and out of the skid steer.
- Never get in or out from the front part of the attachment. The operator must ensure their shoes are free of mud or any other material which could cause them to slip.

### 4.3 Attachment Installation

The attachment must be mounted on the skid steer’s arm in place of the bucket. Apart from the general instructions given below, the procedures outlined in the machine’s manual (see specific section on the application of the attachment) must also be followed.

The outlined instructions below must be carried out for a universal skid steer mount.

1. Position the attachment [Figure 3, Item 1] in the non-operative position and with its skid shoes on flat, compact ground and away from ditches, fuel stores, electrical substations, or any other hazard risk.
2. Slowly bring the arm of the machine towards the attachment in order to position the attachment plate [Item 2] below the upper lip [Item 3] of the attachment mount.
3. Operate the machine hydraulic controls in order to bring the mount plate towards the attachment [Item 2] until it is completely resting on the attachment mount.
4. Turn off the engine of the machine, and remove the key from the ignition. Exit out of the machine and push the two levers [Items 4 and 5] to engage the quick coupling lock pins. Check that the levers are locked in the retaining position and that the pins are inserted in the holes of the attachment mount.



#### CAUTION



When the operations above are completed as described above and the pins inserted are checked, lift the equipment off the ground.

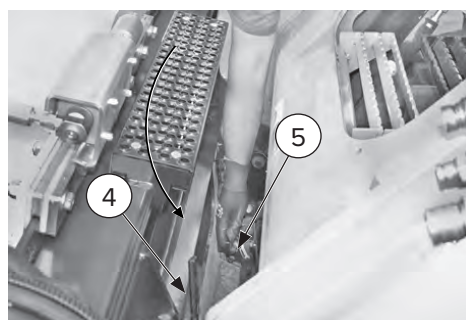
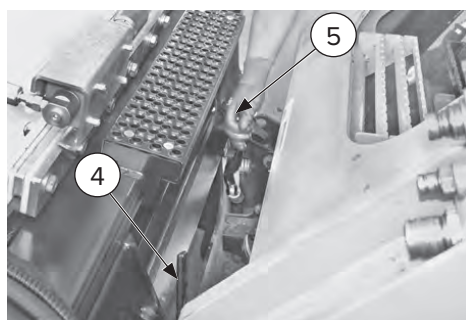
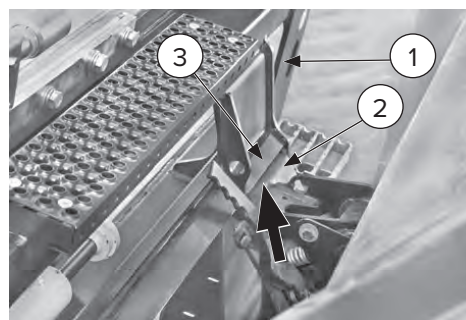
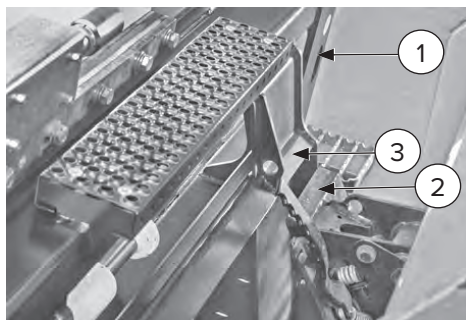

Figure 3

## 4. Use

### 4.4 Connecting Hydraulic Hoses



#### CAUTION



- The machine is connected to the host machine via hydraulic hoses. Make sure the hoses are not tangled together and are not likely to be crushed or exposed to tension during work maneuvers, as this could prove hazardous.
- Residual risk of burns: the hydraulic oil and hoses can reach extremely high temperatures; use appropriate personal protection equipment (PPE).
- The operation must be carried out by one (1) person (the operator) only.

To connect the hoses, proceed as follows:

1. Release the pressure in the hydraulic system (see prime mover instructions).
2. Connect the case drain [Figure 4, Item 2] first, and then connect the supply and return lines [Item 1]. (See “4.5 Connecting Quick Couplers” on page 16.)
3. Connect the 8–way valve hoses [Item 2] using the quick couplers.

4. Connect the electrical cable [Item 3] to the host machine arm socket [Item 4].
5. Check for oil leaks.
  - Enter the machine, and start the engine.
  - Engage the high–flow auxiliary machine control to power the hydraulic motor.
  - Engage the standard auxiliary machine control from the machine to the supply power to the other machine functions.
  - Switch off the engine, remove the ignition key, and exit the host machine. Check for any signs of leaks around the hose couplers.



#### IMPORTANT



- When connecting the hoses to the host machine, the drain line featured must be connected first. The case drain **MUST** be connected to the host machine, otherwise damage will result.
- If screw quick couplers are used, check closely that they have been completely and correctly screwed on.

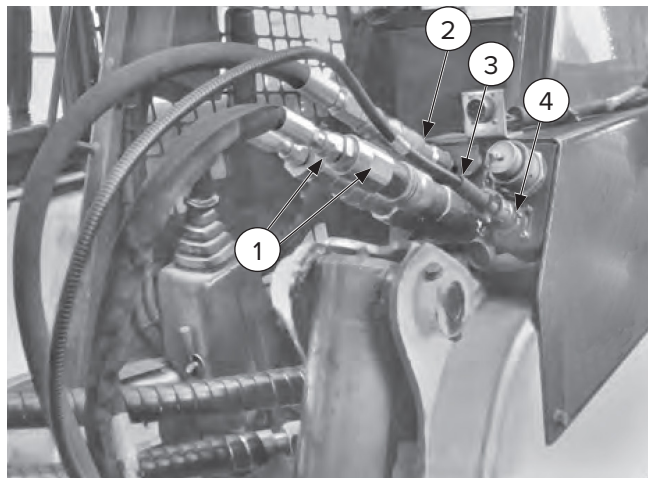

Figure 4

## 4. Use

### 4.5 Connecting Quick Couplers

To connect the flat-faced couplers, proceed as follows:

1. Push the male section [Figure 5, Item 1] into the female section [Item 2] until it clicks into place in the ring nut [Item 3].
2. Turn the ring nut [Item 3] so that the notch [Item 4] is not aligned with the spherule [Item 5], thereby preventing accidental disconnection.

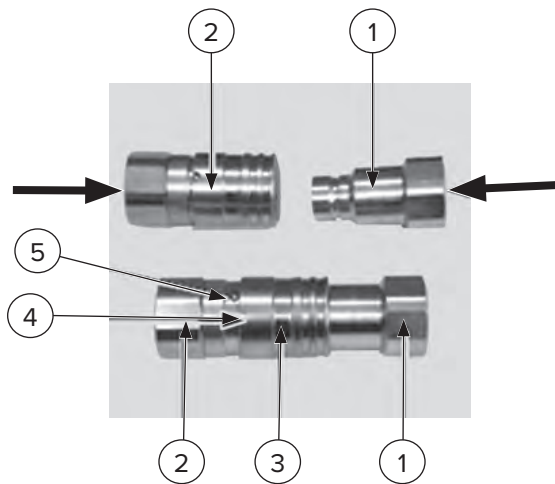

Figure 5

**NOTE:** Figure 5 shows flat-faced quick couplers with a snap-fastening safety ring nut.



### WARNING



- Before connecting together, carefully clean all the quick couplers on the attachment and the prime mover.
- If, for some reason, there is residual pressure in the host machine's hydraulic system, the male section of the coupling will not be able to fit into the female section. Follow the instructions given by the host machine's manufacturer to relieve the pressure.

### 4.6 Disengaging Hydraulic Hoses



### CAUTION



- Before leaving the operator's seat on the machine, make sure the attachment is resting on flat, level ground, the key is removed from the ignition, and the machine is stabilized with the parking brake engaged.
- Residual risk of burns: the hydraulic oil and hoses can reach extremely high temperature; use appropriate personal protection equipment (PPE).



### IMPORTANT



Always disconnect the drain line last.

To disconnect the hoses, proceed as follows:

1. Stop the engine.
2. Discharge the residual pressure in the system.
3. Exit the host machine, and disconnect the quick coupling fittings.
4. To disconnect the hoses with the flat-faced quick couplers: turn the ring nut [Figure 6, Item 3], so that the notch [Item 4] lines up with the spherule [Item 5], push the ring nut [Item 3] towards the spherule [Item 5] to disconnect the quick coupling.



## 4. Use

### 4.7 Disconnecting Attachment from Machine



Ensure that the hydraulic connections have already been disconnected (see “4.6 Disengaging Hydraulic Hoses” on page 16).

How to connect a universal skid steer mount:

1. Position the equipment on firm, level ground and away from ditches, fuel stores, electrical substations, or any other hazard risk.
2. Stop the engine, stabilize the host machine (i.e. with the parking brake, wheel chocks, etc.), and relieve the hydraulic pressure.
3. Remove the ignition key, exit the host machine, and disconnect the hydraulic lines and the electrical cable (see “4.4 Connecting Hydraulic Hoses” on page 15).
4. Pull the two (2) levers [Figure 6, Item 1] towards you to release the quick coupling locking pins.
5. Enter the host machine, and start the engine. Operate the commands to tilt the attachment plate [Item 2] and at the same time, lower the arm [Item 3] until the attachment plate disengages from the upper lips [Item 4] of the attachment.
6. Slowly reverse the host machine away from the attachment.

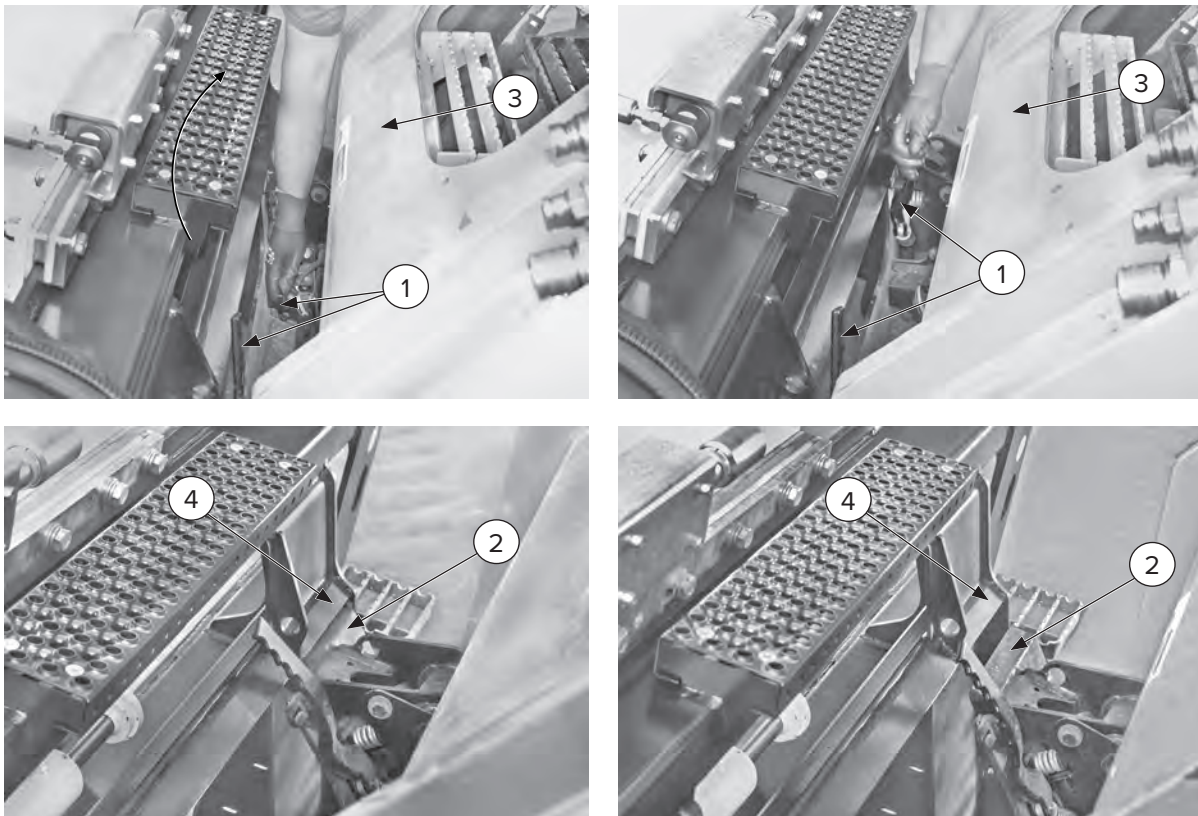

Figure 6

## 4. Use

### 4.8 Pre–Operation



#### CAUTION



- The operation must be carried out by one (1) operator only. Check that nobody is within the host machine's range or within a minimum range of 30 ft (10 m). Cordon off the work area.
- The operator must NOT drive the machine when under the influence of alcohol or drugs, which may impair physical or mental faculties.
- The operator must NOT leave the machine unattended without first engaging the safety locks and removing the ignition keys.
- Always work at a safe distance from open excavations and/or slopes and drop-offs.
- Before getting started, make sure there are no buried pipelines which could interfere with excavation work (gas, water, electricity, etc.).
- During work, keep a close eye out for any oil leaks.
- Check that there are no obstructions or hindrances on the work surface.
- On finishing the work, stop the machine before moving it away from the work surface. Always stop the attachment when the host machine is in transit.



#### WARNING



- The equipment described in this manual is compatible with skid steers with 3 hydraulic lines to enable any additional equipment.
- If the skid steer is NOT equipped to electrically activate the equipment functions, Blue Diamond® will supply a control panel to be installed in the cabin.

The following checks must always be performed prior to starting the equipment:

- Check that there are no leaks in the hydraulic circuit.
- Check that mechanical and electrical connections have been made correctly.
- Check that the work area is free of people and materials.



#### IMPORTANT



Whenever the equipment has been left still or disconnected, start it up slowly with the host machine's engine idling; then accelerate slowly and gradually.

The equipment can only be activated (i.e. drum start rotating) using the controls on the host machine.

1. Turn on the host machine's engine, switch on the hydraulic system and wait for the oil to reach optimum temperature and for any air bubbles in the system to be expelled.
2. Activate the machine High-Flow auxiliary control to start the oil flow and the drum.

**NOTE:** For information on how to activate the hydraulic system, see the machine's Owner's Manual or the user instructions.

### 4.9 Preparing the Equipment for Use

**NOTE:** All these settings must be adjusted with the drum stopped and, if required, with the host machine's motor idle.

Before milling, the operator must prepare the equipment to perform the functions required by excavation or by the surface scarification works. Therefore, he or she must decide the following:

1. Whether to move the cutting unit when milling near walls, curbs, or sidewalks (e.g. beyond the external edge of the prime mover).
2. Milling depth.

## 4. Use

### 4.10 Sideshift Function

Sideshift must be performed with the cold planer raised clear from the ground, and the host machine's motor idle.

Use the host machine joystick controls or the universal control panel to sideshift left or right.

### 4.11 Floating Tilt Function

The Blue Diamond® Cold Planer comes standard with a shock absorber [Item 3] that allows the cutting unit [Figure 7, Item 1] to tilt independently of the mount [Item 2].

During operation, the cutting unit [Item 1] stays level in regards to the planing surface, even if the host machine encounters a raised surface.

The tilt indicator [Item 4] allows the operator to see the tilt angle from the operator's position. The pivot slots [Item 5] limit the tilt angle to eight degrees left and eight degrees right.

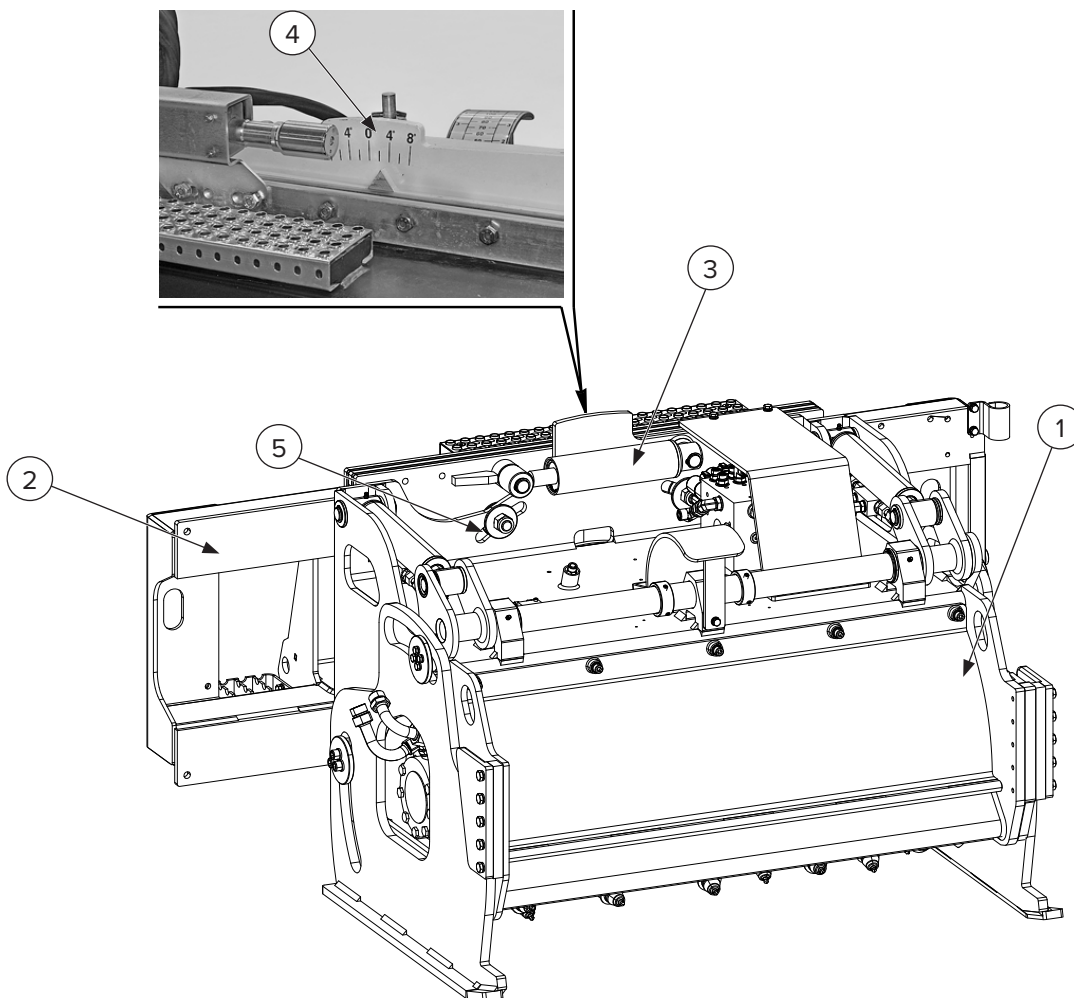

Figure 7

## 4. Use

### 4.12 Planing Depth

#### Adjusting the Planing Depth

**NOTE:** The planing depth is expressed both in millimeters and in inches.

**NOTE:** For a perfect depth adjustment, make sure that the depth indicators have been reset first (see next section).

1. Lift the equipment approximately 2 in. (50 cm) off the ground.
2. Use the machine joystick controls or universal control panel to adjust the planing depth.
3. Use the depth indicator [Figure 8, Item 1] and the reference rod [Item 2] to define the depth reached.

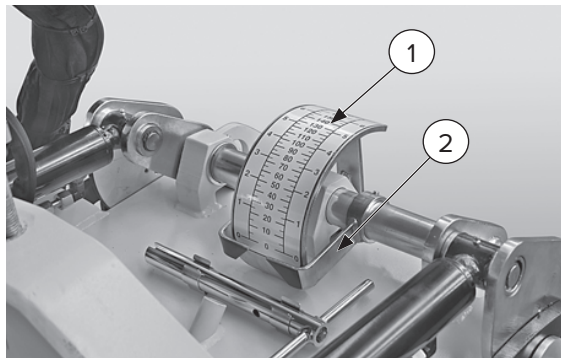

Figure 8

#### Planing Depth Adjustment Reset

If precise planing depth is required, tooth or skid shoe wear may affect the “zero” position shown on the depth indicator.

Due to wear, the depth indicator must be reset for accurate measurement.

Perform the following operations:

1. Perform the following operations:
2. Lower the depth skid until they are fully resting on a flat, level surface.
3. Raise the depth skids to lower the drum until the teeth are barely touching the ground.
4. Open the drum access cover and manually turn the drum. Confirm that all teeth are parallel barely touching the ground.
5. Loosen the set screws [Figure 9, Item 1] on both depth indicator arms.
6. Set both depth indicator arms [Item 2] to “0”.
7. Tighten the set screw [Item 1], and set the desired planing depth.

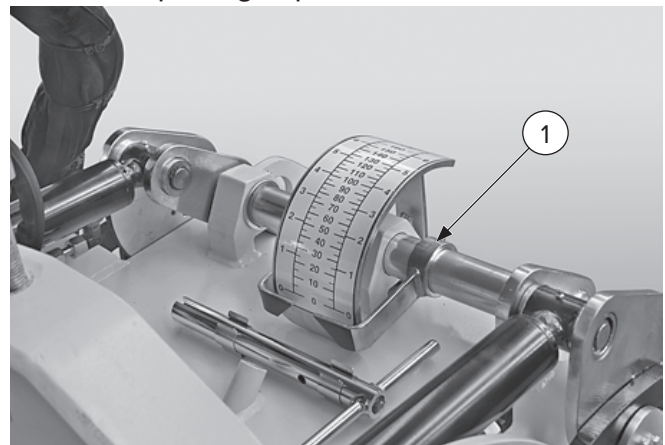

Figure 9

**NOTE:** This adjustment allows the reset to be performed; however it may also make it difficult to reach the maximum depth, due to the hydraulic cylinder’s stroke limit.

## 4. Use

### 4.13 Operating Procedure



#### CAUTION



If no water is sprayed to reduce dust while working, a dust mask or respirator must be worn.

**NOTE:** Before starting to dig, check that the provisions set forth in “4.9 Preparing the Equipment for Use” on page 18 as been observed.

1. Move the equipment to the start of the working site, keeping the unit [Figure 10, Item 1] at the center of the mount to maintain balance.
2. Tilt the attachment forward, resting on the front of the skid shoes [Item 2]. Lift arms until the front wheels or tracks are slightly raised off the ground.

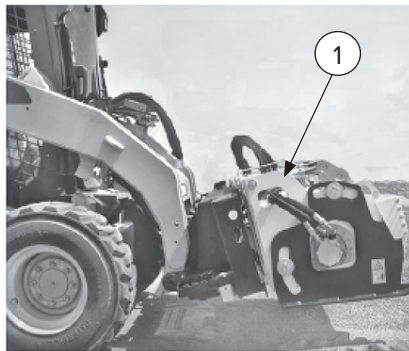

Figure 10

3. With the host machine engine at idle, engage the auxiliary hydraulics, then slowly increase to full engine speed.
4. Using the machine joystick controls or universal control panel, raise the left and right skid shoes alternatively by three-quarters of an inch (20 mm) at a time until the desired planing depth which can be checked on the depth indicator.



#### IMPORTANT



- During the entire procedure to reach the planing depth, make sure that the front tracks or wheels are still raised from the ground.
- The host machine's front tracks or wheels must remain raised during the entire milling operations.

## 4. Use

### 4.13 Work Start Procedure Cont'd

#### If the Drum Stops Due to Foreign Objects

1. Keep the skid steer's lift arm slightly raised, remove the mount plate, and rest the equipment on the ground against the back of the skid shoes, so that the drum can still rotate.
2. Stop the engine, secure the host machine by engaging the parking brake, and exit.
3. Remove the key from the ignition.
4. Remove the screws [Figure 11, Item 1] and open the drum access panel [Item 2].
5. Wearing suitable personal protection equipment (PPE), inspect the drum [Item 3], and try to remove the cause of the blockage.

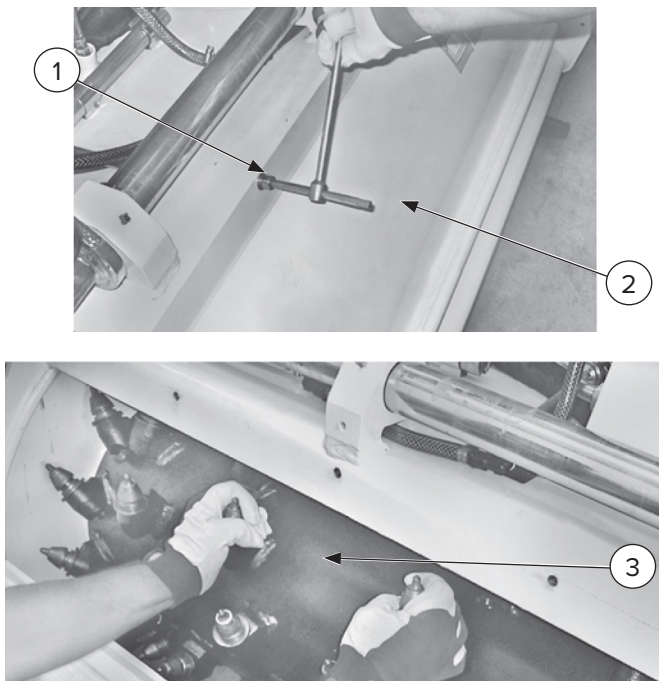

Figure 11

### 4.14 Planing in Parallel Passes

If the desired planing width is greater than the width of the cutting drum, side-by-side planing can be performed.

1. Dig the first trench as described in 4.13 Operating Procedure and, if possible, clean the trench from any debris, to improve its quality and avoid creating steps between one pass and the next.
2. Bring the prime mover at the beginning of the trench, and align with it, so that the drum is placed in line with the trench edge.
3. If debris has been removed from the previous trench, the depth indicator resting on previous trench should be set to zero. The depth indicator resting on the working surface will need to be milled will remain at the planing depth that was previously set during the first pass.



Figure 12

4. The floating tilt function will allow the prime mover to follow the ground's coarseness, and in particular, if required, adapt the tilting with respect to the planer when its wheels go over the already-planned section.
5. Start planing according to the description in 4.13 Operating Procedure.

## 4. Use

### 4.14 Planing in Parallel Passes Cont'd



Figure 13

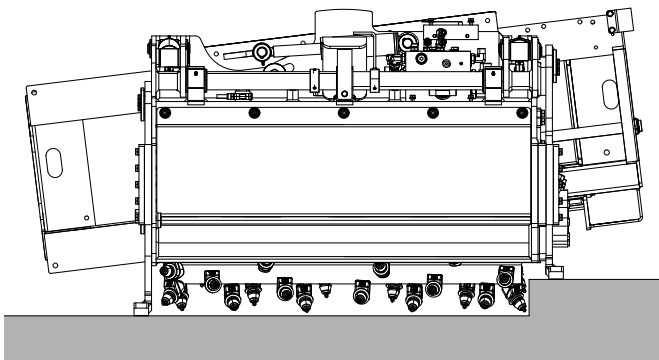

Figure 14

### 4.15 Water Spraying Unit (Optional)

#### ! IMPORTANT !

- Only fill the unit with water that is free from impurities.
- If the tank is installed on the roof of the host machine, DO NOT start the electric pump when the attachment is disconnected from the host machine to avoid damaging it.

Blue Diamond® will supply a control panel with a switch that activates the water spraying pump.

The water container is installed on top of the skid steer.

### 4.16 Stopping the Equipment in Normal Conditions

In normal conditions, the machine joystick controls must be used to stop the machine (by slowing the diesel engine down to idling speed, then cutting off the hydraulic oil flow). This way, the machine will stop immediately.

### 4.17 Emergency Stops

To stop the machine in an emergency, the operator must use the appropriate controls on the host machine and stop the diesel engine with the ignition key.



**WARNING**



For further details on how to stop the machine, refer to the machine's Owner's Manual.

## 4. Use

### 4.18 Parking

Relieve the auxiliary hydraulic pressure. (See the machine's Operator's Manual for correct procedure.)

Park the machine and attachment on a flat, level surface. Engage parking brake. Remove the ignition key.



#### WARNING



- Every time a working cycle ends, bring the milling depth to "0" by lowering the skid shoes all the way and making sure that the equipment is fully resting on the ground.
- Park the host machine in a suitable place where there are no risks of the attachment or host machine being damaged.
- If the operator leaves the host machine and attachment unattended, the keys must be removed from the host machine and measures must be taken to ensure no unauthorized persons can enter and use it.

### 4.19 Preparing the Unit for Long Periods of Inactivity

If the attachment is not to be used for some time, it must be stored in a sheltered area where it cannot get knocked or hit.

Position the cold planer on a pallet (making sure it is stable), then proceed as follows:

1. Wash it carefully.
2. Check for and fix any oil leaks.
3. Check for and replace any damaged parts.
4. Remove the tools, and apply a water-based asphalt emulsifier (ex. Zep's #AR6690) or dish soap (ex. Dawn dish soap) to them.
5. Apply a water-based asphalt emulsifier (ex. Zep's #AR6690) or dish soap (ex. Dawn dish soap) to the tooth holder.
6. Lubricate the depth and movement adjustment piston exposed parts.
7. Place a sheet over the attachment to protect it from dust.

8. Cordon off the area where the attachment is located to prevent anyone accidentally knocking against its corners, sharp edges, or blunt parts.

### 4.20 Recommissioning the Unit after Long Periods of Inactivity

Before starting up the attachment again after a long period of disuse, the following checks must be carried out:

1. Grease all the pivot points.
2. Check for and fix any oil leaks.
3. Check the condition of the hoses.
4. Check that there are loose, worn out, or missing parts.
5. Check all hardware for proper torque.

### 4.21 Disposal

When disposing of the equipment or its parts (oil, hoses, plastic parts, etc.), always comply with the local, state, and federal laws.



## 5. Maintenance

### 5.1 Service Schedule

DESCRIPTION	SERVICE PROCEDURES					
	Check	Clean	Lube	Change	Adjust	Drain
<b>Hourly Maintenance</b>						
Drum	•					
Teeth	•					
<b>8 Hour Maintenance</b>						
Water Kit Nozzles	•					
<b>50 Hour Maintenance</b>						
Lubrication			•			
Hoses	•					
Equipment		•				
<b>100 Hour Maintenance</b>						
Frame (cracks, bends, or damage)	•					
All Hardware	•				•	
<b>200 Hour Maintenance</b>						
Drain Line Safety Cover	•					
<b>When Required</b>						
Skid Shoes				•		
Teeth				•		

**NOTE:** Contact Blue Diamond® Product Support with any questions.

## 5. Maintenance



### WARNING



- All maintenance work must be carried out with the attachment detached from the host machine and positioned on the ground.
- Maintenance operations must be carried out in a suitable place, in compliance with the safety regulations in force.
- Clean all parts of the equipment thoroughly before beginning any maintenance work on it (see “Equipment Cleaning” on page 29 under 5.4 Every 50 Hours).
- Appropriate personal protective equipment (PPE) must be used throughout maintenance.

### 5.2 Every Hour

#### Inspection of the Drum

There are two (2) checks to be performed on the drum: the quality of the teeth and any damage or missing tooth holders.



### WARNING



- Never work with damaged and/or missing teeth and tooth holders.
- Before leaving the operator’s position, make sure the surface is flat and level, the host machine is stable, the attachment is resting on the ground, and the keys have been removed from the ignition.

The drum is the most important element of the equipment.

Because of the type of work it does, it is easily damaged.

Visually check the drum after it hits any solid object, such as hatches, iron obstacles, manholes, etc.

**NOTE:** Just like the teeth, the drum is subjected to wear, and therefore excluded from the warranty.

**NOTE:** If the drum is very damaged (missing or broken tooth holders, etc.), contact Blue Diamond® Product Support.

To inspect the drum, adjust the depth indicator to zero or as minimal as possible, and rest the attachment on a flat, level surface. Then perform the following operations:

1. Keeping the skid steer lift arms lowered, remove the mount plate, and rest the attachment on the ground by keeping the drum slightly raised.
2. Remove the screws [Figure 15, Item 1], and open the drum access panel [Item 2].
3. Grip the teeth to make the drum [Item 3] turn in the work direction, and inspect it.

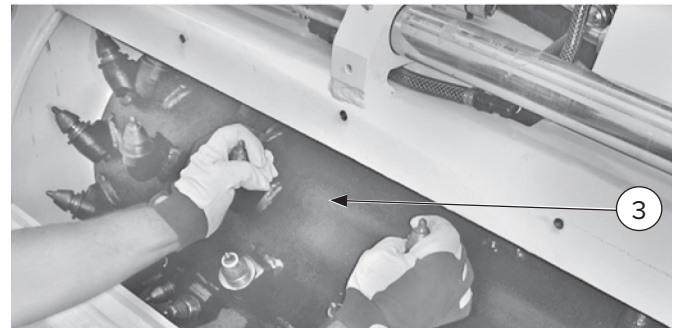
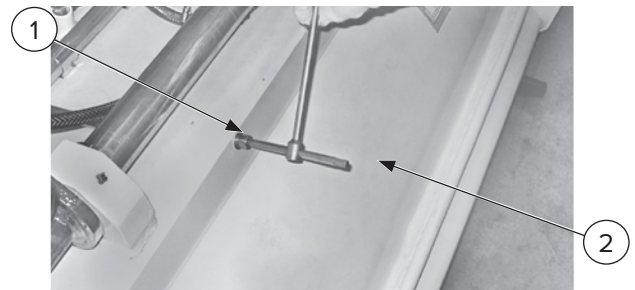

Figure 15

#### Tooth Quality



### WARNING



- Never work with damaged and/or missing teeth and teeth holders.
- Before leaving the operator’s position, make sure the surface is flat and level, the host machine is stable, the attachment is resting on the ground, and the keys have been removed from the ignition.

Every tooth is subject to constant wear due to contact with the material cut. The greater the wear, the less the tooth’s capability for breaking into the material.

## 5. Maintenance

### 5.2 Every Hour Cont'd

#### Tooth Quality Cont'd

As tooth wear increases, the quality of work decreases. This means that if extremely worn teeth are used, the attachment's productivity drops noticeably.

Replacing the teeth promptly will ensure the attachment is always working at full performance.

It is always worthwhile checking for signs of wear as the tooth only really performs well throughout its working life if it is worn down evenly.

To check the drum and replace the teeth if required, remove the screws [Figure 16, Item 1] and tilt the drum access cover [Item 2] outward.

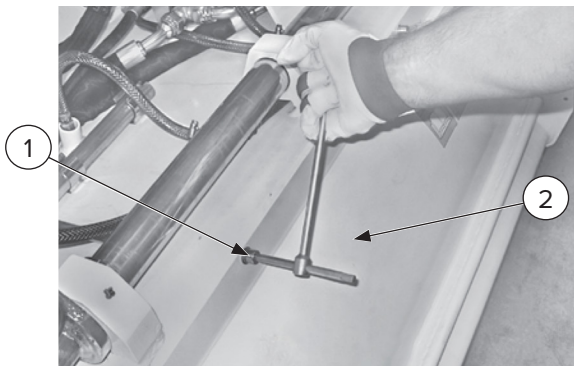

Figure 16

#### Tooth Wear

Figure 17 shows features of an ideally worn tooth that needs replaced.

The remaining part of the carbide tip is symmetrically shaped, and the body has a uniform, tapered shape and enough bulk to support the carbide core.

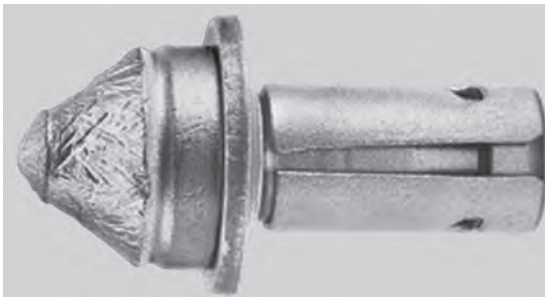

Figure 17

Figure 18 shows a tooth that has worked on soft materials and needs replaced.

If a tooth has been used on material that is too soft, the body will wear quicker than the tip, and the tip will end up snapping off. The altered tooth shape will also increase the wear of the tooth holder.

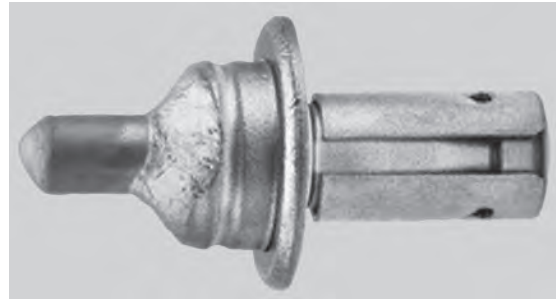

Figure 18

Figure 19 shows a tooth that has not been rotated properly and needs replaced.

Uneven wear will cause the tooth to wear out quicker when compared to normal. Uneven wear is always caused by the tooth not being able to rotate within the tooth holder. This can be caused by a worn tooth holder or debris stuck between the tooth and its holder. If there is trapped debris, clean the holder and lubricate with a water-based asphalt emulsifier (ex. Zep's #AR6690) or dish soap (ex. Dawn dish soap).



Figure 19

**NOTE:** The teeth shown in Figures 17–19 are standard models. Similar concepts apply to all teeth models.

## 5. Maintenance

### 5.2 Every Hour Cont'd

#### Assessment Procedure

1. Visually inspect to establish the degree of wear.
2. Check that the teeth can turn freely in their holders.

Following the assessment, replace any broken teeth or those showing excessive wear. Clean the holders of those which will not turn as shown in Figure 20.



Figure 20

#### Cleaning the Tooth

1. Remove the tooth which is not rotating (see "Removal" on page 31 under 5.7 When Required).
2. Clean the tooth shank and the holder in which it is fitted.
3. Lubricate with a water-based asphalt emulsifier (ex. Zep's #AR6690) or dish soap (ex. Dawn dish soap).
4. Refit the tooth in its holder.

**NOTE:** If the tooth rotates to some extent, lubrication with a water-based asphalt emulsifier (ex. Zep's #AR6690) or dish soap (ex. Dawn dish soap) can be performed without removing the tooth from its holder.

### ! IMPORTANT !

To make it easier to turn the teeth in their holders and, therefore, lengthen their working life, it is recommended to apply a water-based asphalt emulsifier (ex. Zep's #AR6690) or dish soap (ex. Dawn dish soap) to the rear of the tooth at the end of the working day, making sure the emulsifier seeps in between the tooth and the holder.



### WARNING



- Never let the drum rotate freely with new or freshly lubricated teeth, as they could come out of their holders due to centrifugal force.
- Never work with badly damaged and/or stuck teeth so as to avoid the tooth holders being damaged.

### 5.3 Every 8 Hours

#### Cleaning the Water Nozzles of the Optional Water Kit

1. Check the water nozzles [Figure 21, Item 1] located on the attachment and clean them if necessary.
2. When reinstalling them, pay attention to the orientations of the nozzles [Item 1], which must be installed with the water spray slit [Item 2] parallel to the drum rotation axis.

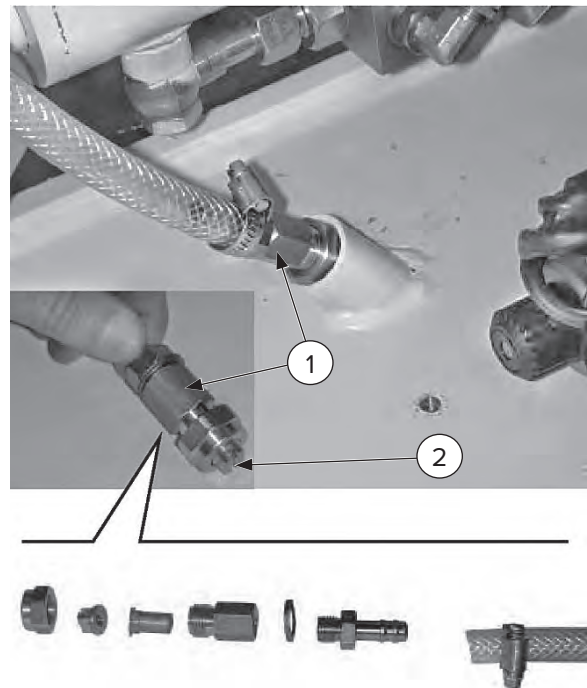

Figure 21

## 5. Maintenance

### 5.4 Every 50 Hours

#### Lubrication

Lubricate the joints of depth indicators, shock absorber, and sideshift pivot points as shown in Figure 22.

To lubricate them, inject and spread NLGI 2 – EP Lithium grease until all the worn-out grease comes out.



**WARNING**



Clean the grease nipples thoroughly before connecting the grease pump.

Before performing maintenance, place the attachment on the a flat, level surface, shut down the host machine, and remove the ignition key.

1. Grease each grease zerk.
2. Once greasing has been completed, remove all dirty grease which has been expelled to prevent damage from deposits of dirt and debris.

#### Check the Condition of the Hoses

Check the condition of the hoses and the crimping of the fittings. If a hose shows signs of aging, leaks, breakages, bulges, abrasions etc., it should be replaced.

1. Clean the working area to keep dirt from entering the hydraulic circuit.

2. Replacement must be carried out by qualified personnel, using all necessary PPE.
3. The new hose must be the same size and specifications as the previous one and be rated for the pressure indicated within this manual.

For tightening torques, see “Tightening Torques for Hoses” on page 68 under 8.2 Torque Specifications.

#### Equipment Cleaning

Use legally approved, neutral detergents. Clean the attachment with a high pressure jet of water.

### 5.5 Every 100 Hours

#### Structural Integrity Assessment

Clean the attachment carefully prior to the inspection. Inspect the bearing framework visually to check its integrity, focusing particularly on the welding. If any weakening or small cracks are noticed, contact Blue Diamond® Product Support for assistance.

#### Check Hardware Torque

Check that all the nuts and bolts are securely fastened, and tighten them if necessary.

For tightening torques, see “Standard Hardware and Lock Nuts” on page 66 under 8.2 Torque Specifications.

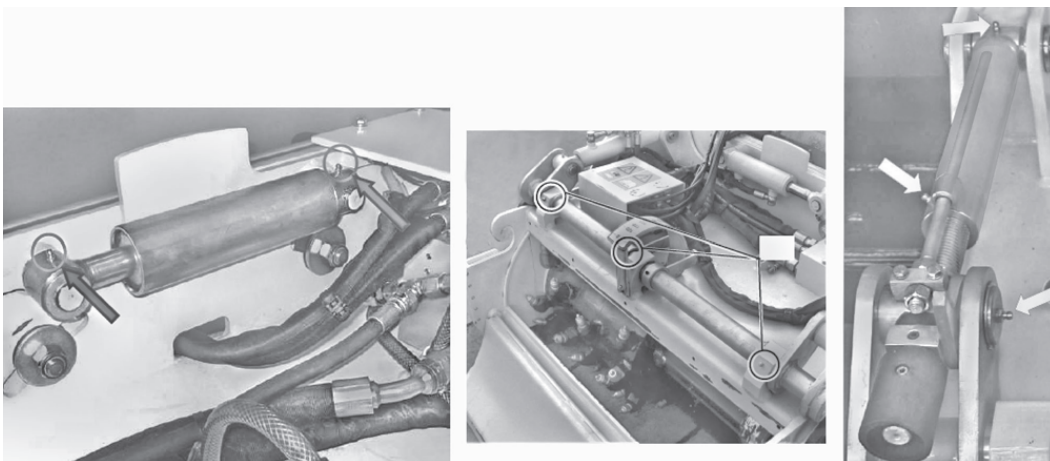

Figure 22

## 5. Maintenance

### 5.6 Every 200 Hours

#### Case Drain Line Safety Cover Inspection

To prevent damage to the motor due to high backpressure in the case drain line, a safety cover [Figure 23, Item 1] has been fitted, which allows excess pressure to be relieved. When the drain line pressure exceeds 15 PSI (1 bar), the cover deforms and allows oil out, thereby releasing the excess pressure.

If any deformation and consequent leakage is noticed, check the case drain line pressure (max. 15 PSI or 1 bar) and the circuit. Replace the cover [Item 1] and the relative O-ring. Contact Blue Diamond® Product Support for more information.

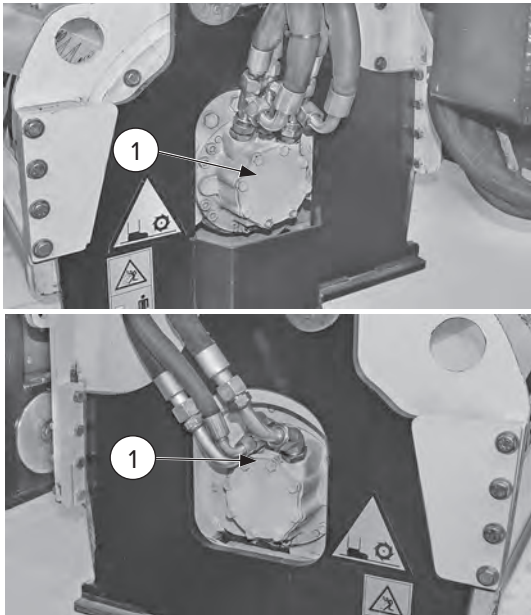

Figure 23

### 5.7 When Required

#### Replacing the Skid Shoes

The skid shoes [Figure 24, Item 1] are made of special anti-wear steel and are fastened to the side of the cold planer [Item 2].

To replace them, contact Blue Diamond® Product Support for more information.

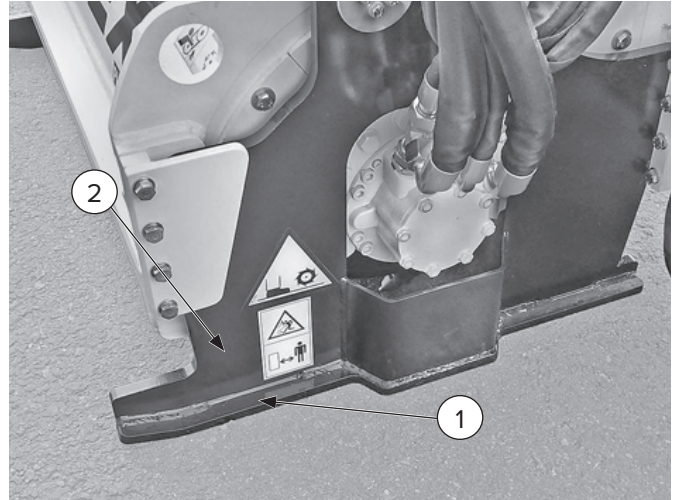

Figure 24

### ! IMPORTANT !

When inspecting or replacing the cover, clean both the cover and the surrounding area, ensuring that impurities do not enter the case drain line.

### ! WARNING !

The new fitted cap **MUST** have the same thickness as the original one.

## 5. Maintenance

### 5.7 When Required Cont'd

#### Teeth Replacement

##### Removal

1. The teeth [Figure 25, Item 1] are held in the tooth holder by a retaining spring.
2. Position the tool [Item 2] supplied as shown below.
3. Hit the tool [Item 2] with a hammer to remove the teeth.

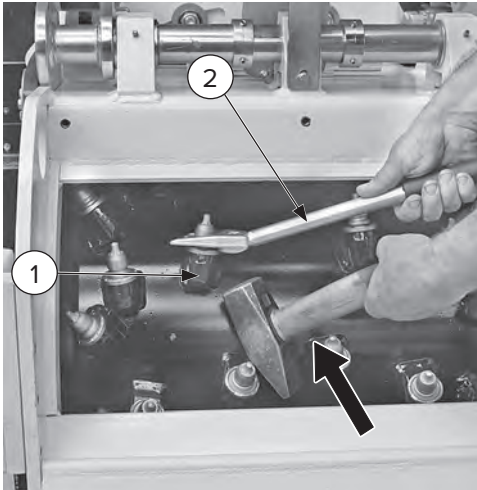
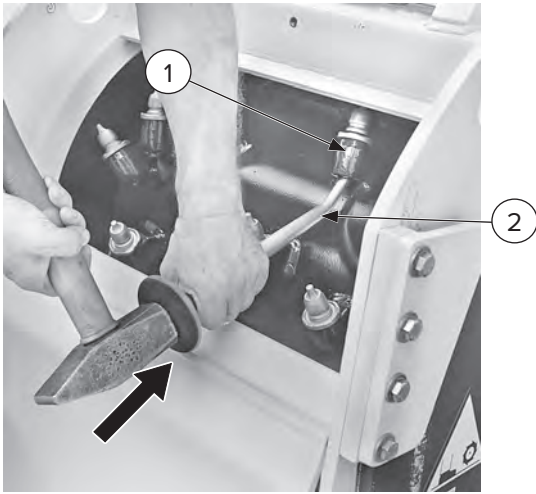

Figure 25

##### Assembly

1. Before fitting new teeth, clean and lubricate the holder with a water-based asphalt emulsifier (ex. Zep's #AR6690) or dish soap (ex. Dawn dish soap).
2. Insert the tooth [Figure 26, Item 1] into its holder using light blows with a copper hammer until the tooth top is fully inserted.
3. If a copper hammer is not available, place a short section of pipe with a 3/4" – 1" inside diameter or a piece of wood over the tooth. Lightly hammer the piece of pipe or wood. DO NOT directly hit the carbide tip with a hard hammer as this could cause damage.

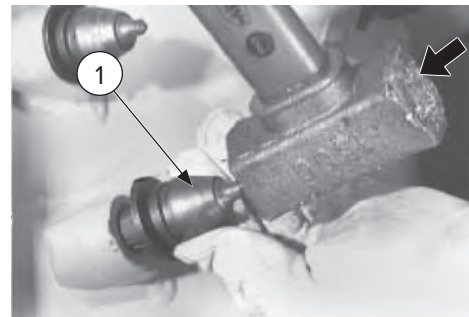

Figure 26

#### Special Maintenance

For uncommon maintenance procedures, contact Blue Diamond® Product Support for assistance.

### 5.8 Spare Parts & Accessories

Contact Blue Diamond® Product Support.

## 5. Maintenance

### 5.9 Troubleshooting

PROBLEM	CAUSE	SOLUTION
Slow planing, low performance	Teeth tips worn or broken	Replace the teeth, and clean their holders.
	Low flow and/or hydraulic pressure	Ensure all necessary connections have been made correctly for attachment operation.
Contact the service department to check the flow and hydraulic pressure.		
Vibrations	Loose or missing bolts	Check the tightening torques of the bolts (hydraulic motor, etc).
		Replace the missing screws.
	Worn or missing teeth	Replace the teeth, and clean their holders.
Noisy or jammed hydraulic motor	Problems inside the motor.	Contact Blue Diamond® Product Support.
Drum does not turn	No hydraulic flow and/or pressure	Check the host machine's hydraulic system.
	Quick couplers not fitted properly	Fit quick couplers properly.
	Other hydraulic or electric issues	Contact Blue Diamond® Product Support.
Sideshift is not working	The electrical cable is disconnected	Connect the electrical cable.
	Quick couplers not fitted properly	Fit quick couplers properly.
	Selection valve dirty	Clean the valve.
Drum turns too slowly or too fast	Incorrect attachment to host machine coupling	Contact Blue Diamond® Product Support.
External oil leaks	Fittings are loose	Tighten fittings.
	Hosing damaged	Replace hosing.
	Couplers damaged	Replace couplers.
	Leaks from the hydraulic motor oil seals	Contact Blue Diamond® Product Support.
Safety cover swollen	Drainage line high backpressure and/or case drain line missing or fitted incorrectly to the host machine	Always connect the case drain line directly to the host machine
		Replace the cover and O-ring and to check the backpressure which should be < 15 PSI (1 bar). Contact Blue Diamond® Product Support for further assistance.
	Drainage line high backpressure and/or case drain line hose damaged	Replace the hose.
		Replace the cover and O-ring and to check the backpressure which should be < 15 PSI (1 bar). Contact Blue Diamond® Product Support for further assistance.
	Sudden start-up of attachment with host machine engine at maximum speed	Start up the attachment with the engine idling, then after a few seconds, accelerate slowly and gradually until the operating speed is reached.
		Replace the cover and O-ring and to check the backpressure which should be < 1 bar. Contact Blue Diamond® Product Support for further assistance.
Backpressure in host machine's case drain line is too high	Replace the cover and O-ring and to check the backpressure which should be < 15 PSI (1 bar). Contact Blue Diamond® Product Support for further assistance.	



## 6. Wire Harness Control Guide

### 6.1 Warning



Before using the Extreme Duty Series 2 Cold Planer, make sure that the electronic control unit (ECU) is supplied with a current of +12 volts. Green light indicator is flashing.

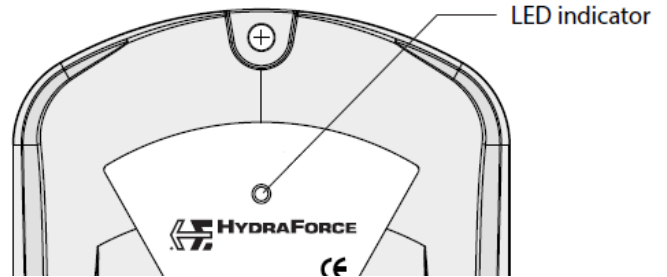

### 6.2 Universal Controller

PIN	DESCRIPTION
E	Shift the equipment to the left
F	Shift the equipment to the right
C + E	Decrease the working depth (left)
C + F	Increase the working depth (left)
D + E	Decrease the working depth (right)
D + F	Increase the working depth (right)
H + E	Clockwise tilt
H + F	Counterclockwise tilt
J	Activation of water pump (if equipped)

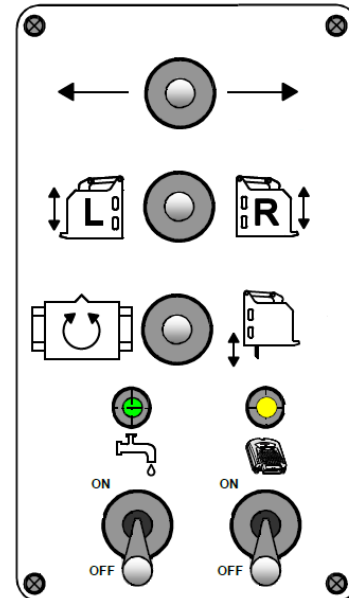

## 6. Wire Harness Controls

### 6.3 Bobcat

PIN	DESCRIPTION
G	Shift the equipment to the left
H	Shift the equipment to the right
D + G	Decrease the working depth (left)
D + H	Increase the working depth (left)
C + G	Decrease the working depth (right)
C + H	Increase the working depth (right)
F + G	Clockwise tilt
F + H	Counterclockwise tilt
E	Activation of water pump (if equipped)

**NOTE:** The The control for pin “E” is under relay. The first click will power the water pump. The second click will turn it off.



### 6.4 CASE & New Holland

PIN	DESCRIPTION
E	Shift the equipment to the left
F	Shift the equipment to the right
C + E	Decrease the working depth (left)
C + F	Increase the working depth (left)
D + E	Decrease the working depth (right)
D + F	Increase the working depth (right)
H + E	Clockwise tilt
H + F	Counterclockwise tilt
J	Activation of water pump (if equipped)

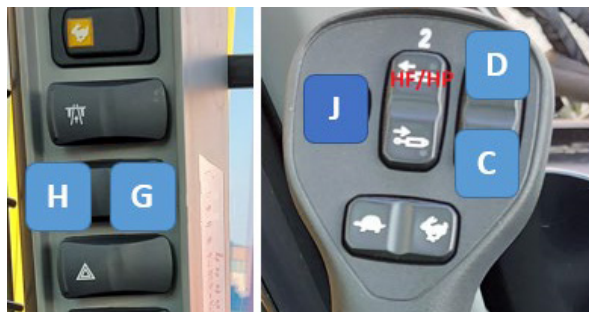
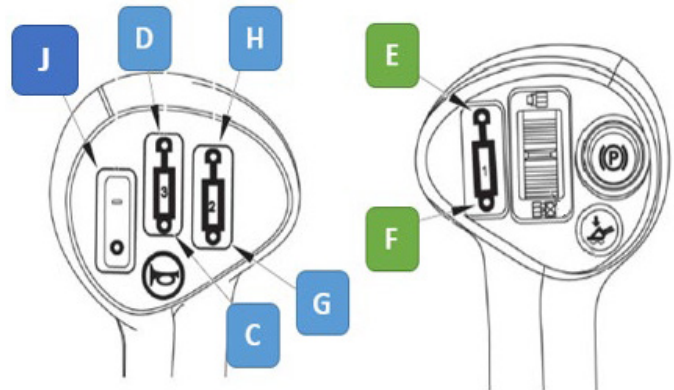

## 6. Wire Harness Controls

### 6.5 CAT D XPS / XHP

PIN	DESCRIPTION
D	Shift the equipment to the left
C	Shift the equipment to the right
D + E	Decrease the working depth (left)
C + E	Increase the working depth (left)
D + F	Decrease the working depth (right)
C + F	Increase the working depth (right)
D + A	Clockwise tilt
C + A	Counterclockwise tilt
C + D	Press the buttons simultaneously to activate the water pump (if equipped)

**NOTE:** The control for pin “C + D” is under relay. The first click will power the water pump. The second click will turn it off.

⚠
IMPORTANT
⚠

Before using the Extreme Duty Series 2 Cold Planer, make sure that the electronic control unit (ECU) is supplied with a current of +12 volts by activating the AUX 8 panel switch.

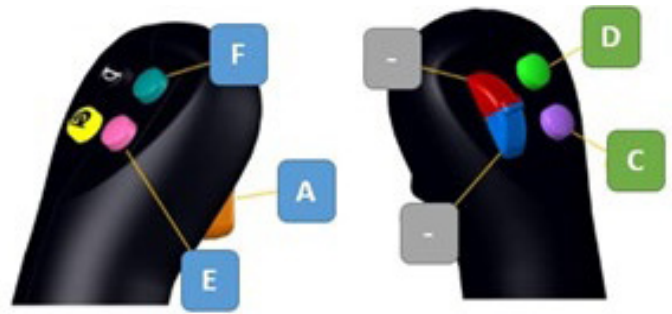

### 6.6 CAT D3 XPS / XHP X XE

PIN	DESCRIPTION
D	Shift the equipment to the left
C	Shift the equipment to the right
D + E	Decrease the working depth (left)
C + E	Increase the working depth (left)
D + F	Decrease the working depth (right)
C + F	Increase the working depth (right)
D + A	Clockwise tilt
C + A	Counterclockwise tilt
J (AUX 8)	Activation of water pump (if equipped)

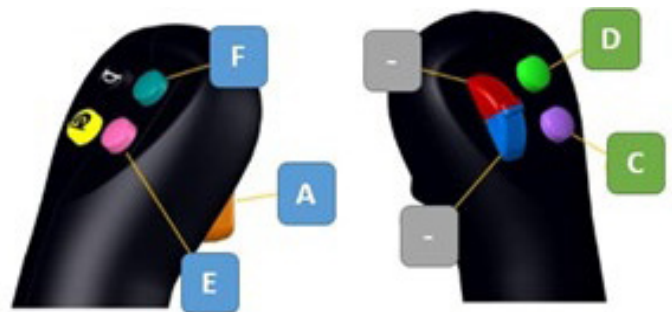

## 6. Wire Harness Controls

### 6.7 Gehl / Manitou / Mustang

PIN	DESCRIPTION
E	Shift the equipment to the left
F	Shift the equipment to the right
C + E	Decrease the working depth (left)
C + F	Increase the working depth (left)
D + E	Decrease the working depth (right)
D + F	Increase the working depth (right)
H + E	Clockwise tilt
H + F	Counterclockwise tilt
A	Activation of water pump (if equipped)

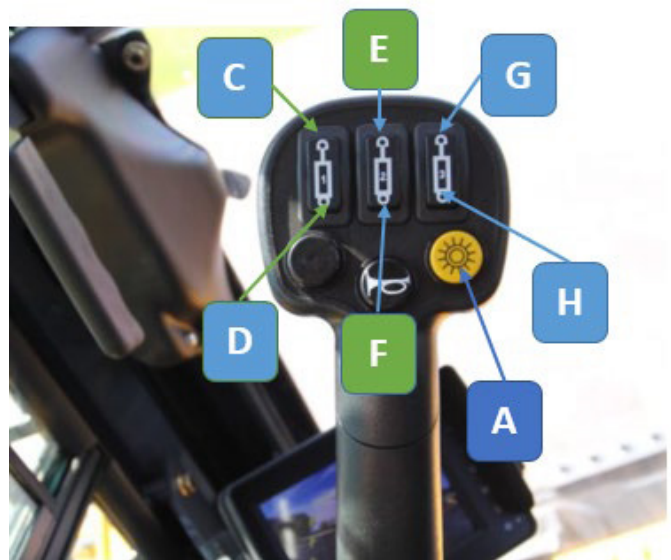

### 6.8 JCB / Volvo – Post 10 / 2010

PIN	DESCRIPTION
C	Shift the equipment to the left
D	Shift the equipment to the right
E + C	Decrease the working depth (left)
E + D	Increase the working depth (left)
F + C	Decrease the working depth (right)
F + D	Increase the working depth (right)
G + C	Clockwise tilt
G + D	Counterclockwise tilt
H	Activation of water pump (if equipped)

**NOTE:** The control for pin “H” is under relay. The first click will power the water pump. The second click will turn it off.

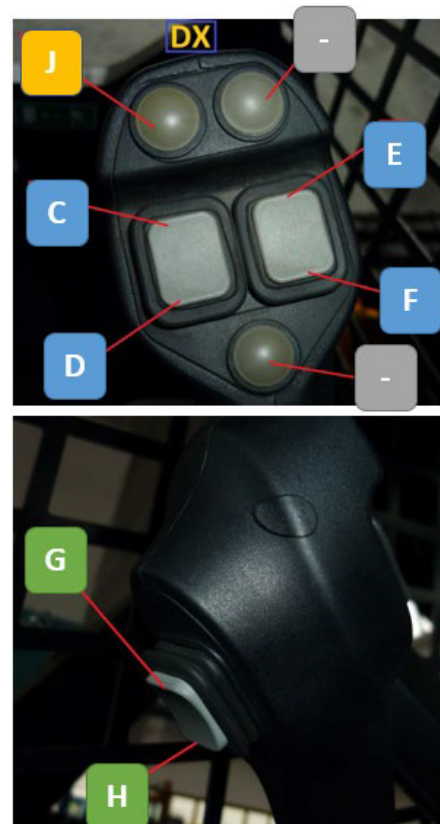

Before using the Extreme Duty Series 2 Cold Planer, make sure that the electronic control unit (ECU) is supplied with a current of +12 volts by activating the “J” switch.

## 6. Wire Harness Controls

### 6.9 JCB / Volvo – New Series 3.x

PIN	DESCRIPTION
C	Shift the equipment to the left
F	Shift the equipment to the right
C + E	Decrease the working depth (left)
C + F	Increase the working depth (left)
D + E	Decrease the working depth (right)
D + F	Increase the working depth (right)
H + E	Clockwise tilt
H + F	Counterclockwise tilt
A	Activation of water pump (if equipped)

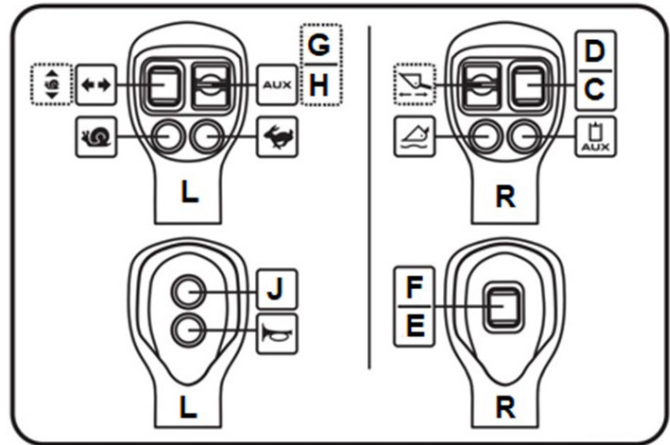

### 6.10 John Deere

PIN	DESCRIPTION
E	Shift the equipment to the left
D	Shift the equipment to the right
G + E	Decrease the working depth (left)
G + D	Increase the working depth (left)
C + E	Decrease the working depth (right)
C + D	Increase the working depth (right)
F + E	Clockwise tilt
F + D	Counterclockwise tilt
H	Activation of water pump (if equipped)



**NOTE:** The control for pin “H” is under relay. The first click will power the water pump. The second click will turn it off.

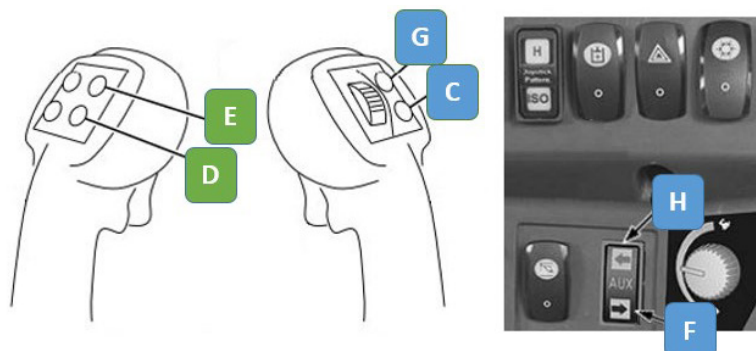

## 6. Wire Harness Controls

### 6.11 Kubota

PIN	DESCRIPTION
E	Shift the equipment to the left
F	Shift the equipment to the right
C + E	Decrease the working depth (left)
C + F	Increase the working depth (left)
D + E	Decrease the working depth (right)
D + F	Increase the working depth (right)
H + E	Clockwise tilt
H + F	Counterclockwise tilt
A	Activation of water pump (if equipped)



### 6.12 Takeuchi

PIN	DESCRIPTION
G	Shift the equipment to the left
H	Shift the equipment to the right
D + G	Decrease the working depth (left)
D + H	Increase the working depth (left)
C + G	Decrease the working depth (right)
C + H	Increase the working depth (right)
F + G	Clockwise tilt
F + H	Counterclockwise tilt
E	Activation of water pump (if equipped)



**NOTE:** The control for pin “E” is under relay. The first click will power the water pump. The second click will turn it off.

## 6. Wire Harness Controls

### 6.13 Wacker Neuson

PIN	DESCRIPTION
F	Shift the equipment to the left
E	Shift the equipment to the right
C + F	Decrease the working depth (left)
C + E	Increase the working depth (left)
D + F	Decrease the working depth (right)
D + E	Increase the working depth (right)
L + F	Clockwise tilt
L + E	Counterclockwise tilt
J	Activation of water pump (if equipped)

### ! IMPORTANT !

Before using the Extreme Duty Series 2 Cold Planer, make sure that the electronic control unit (ECU) is supplied with a current of +12 volts. Green light indicator is flashing. Select position “D” on the control panel (see machine’s Operator’s Manual).

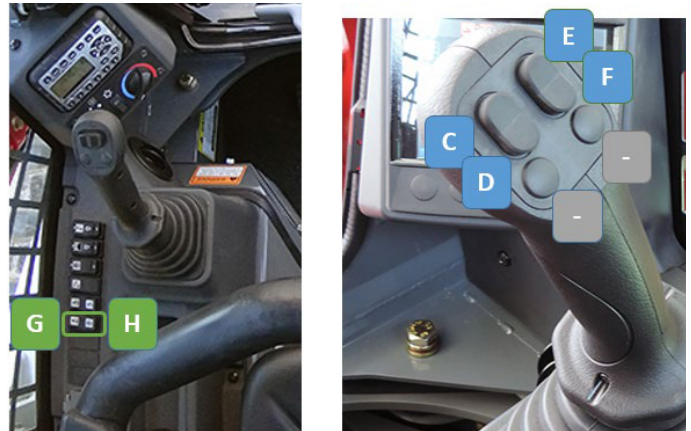

### 6.14 Yanmar

PIN	DESCRIPTION
E	Shift the equipment to the left
F	Shift the equipment to the right
D + E	Decrease the working depth (left)
D + F	Increase the working depth (left)
C + E	Decrease the working depth (right)
C + F	Increase the working depth (right)
A + D + F	Clockwise tilt
A + D + E	Counterclockwise tilt
A + C (G)	Activation of water pump (if equipped)



**NOTE:** The control for pin “A + C” is under relay. The first click will power the water pump. The second click will turn it off.

# 7. Parts

## 7.1 Main Components – Both Models

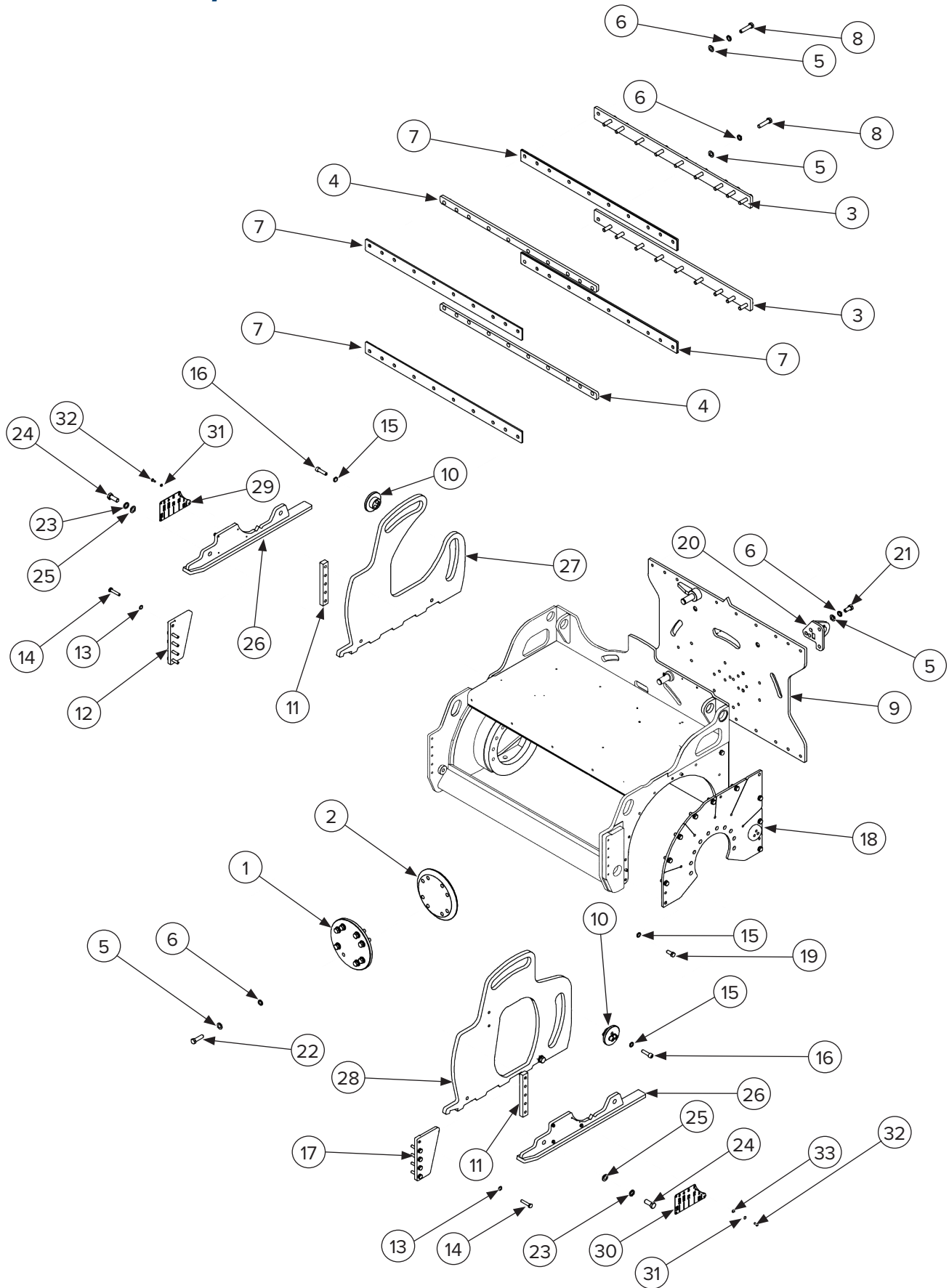



## 7. Parts

### 7.1 Main Components – Both Models Cont'd

ITEM	PART NUMBER	DESCRIPTION	QTY
1	260801	Chassis Pivot Front Plate	1
2	260811	Chassis Pivot Back Plate	1
3	260807	Sideshift Slide Clamp Plate 35mm x 13.5mm x 950mm	2
4	260808	Sideshift Slide Center Spacer Plate 35mm x 13.5mm x 950mm	2
5	—	M14 Flat Washer UNI 6592	31
6	—	M14 Lock Washer	31
7	260809	Sideshift Slide Poly Plate 60mm x 8mm x 950mm	4
8	—	M14 x 2mm x 60mm Bolt Hex Head	20
9	260813	Chassis Mount Plate	1
10	260723	Skid Plate Rear Float Bushing	2
11	260802	Skid Plate Guide Spacer Plate 20mm Thick	2
12	260805	Skid Plate Guide Right Side	1
13	—	M10 Lock Washer	10
14	—	M10 x 1.5mm x 50mm Bolt Hex Head	10
15	—	M12 Lock Washer	17
16	—	M12 x 1.75mm x 45mm Bolt Socket Head	6
17	260806	Skid Plate Guide Plate Left Side	1
18	260803	Left Side Motor to Chassis Plate	1
19	—	M12 x 1.75mm x 30mm Bolt Hex Head Fully Threaded	11
20	260729	Sideshift Cylinder Mount Rod End	1
21	—	M14 x 2mm x 30mm Bolt Hex Head Fully Threaded	3
22	—	M14 x 2mm x 50mm Bolt Hex Head Fully Threaded	8
23	—	M16 Lock Washer	4
24	—	M16 x 2mm x 40mm Bolt Hex Head Fully Threaded	4
25	—	M16 Flat Washer UNI 6592	4
26	260812	Skid Shoe	2
27	260817	Skid Plate Right Side	1
28	260799	Skid Plate Left Side	1
29	260814	Front of Cut Right Indicator Plate	1
30	260815	Front of Cut Left Indicator Plate	1
31	—	M6 Lock Washer	8
32	—	M6 x 1mm x 14mm Bolt Hex Head Fully Threaded	8
33	—	M6 Flat Washer UNI 6592	8

# 7. Parts

## 7.2 Frame Components — Both Models

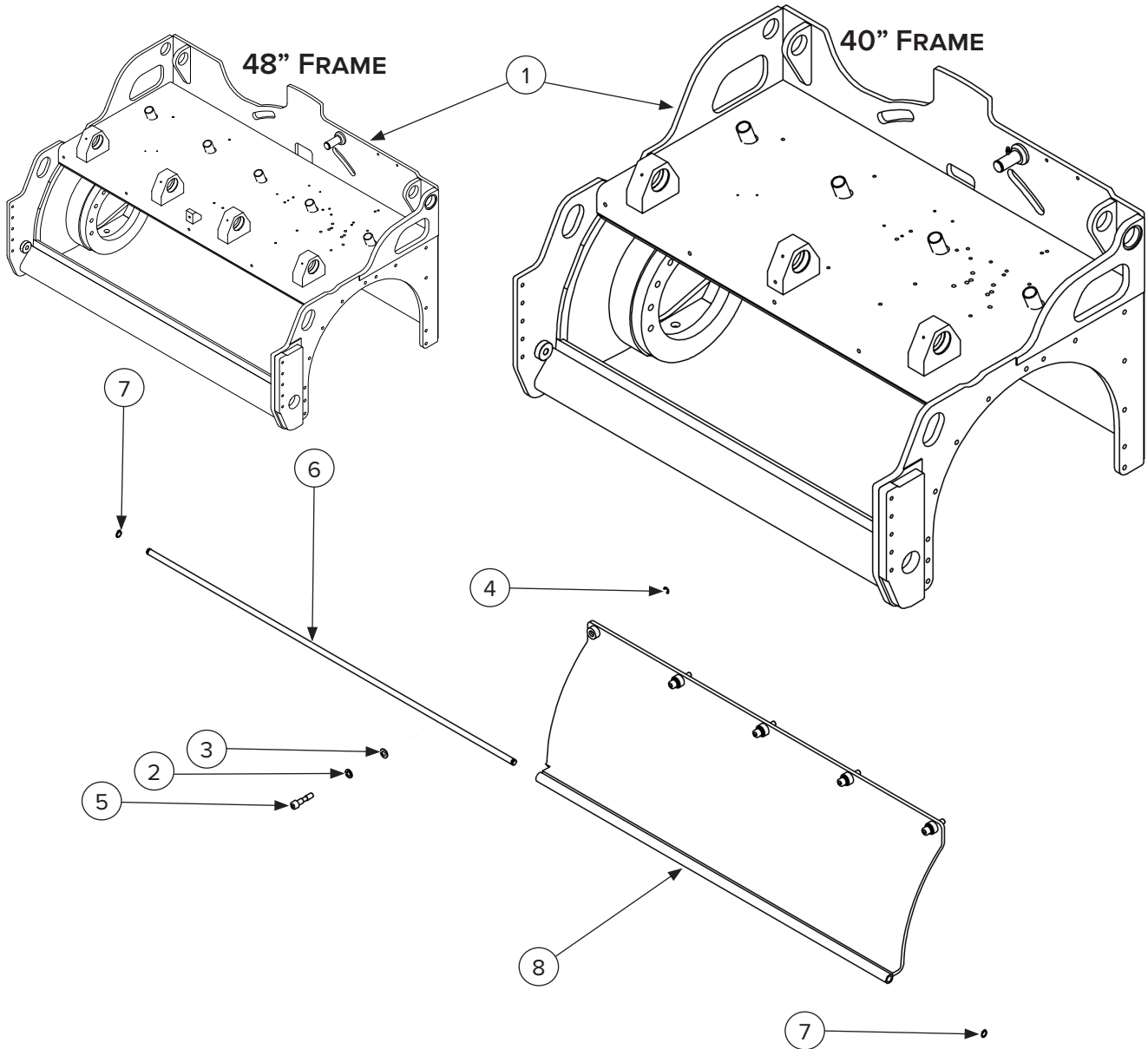

ITEM	PART NUMBER	DESCRIPTION	40" QTY	48" QTY
1	260816	Chassis Frame Weldment	1	—
	260836		—	1
2	—	M10 Lock Washer	5	5
3	—	M10 Flat Washer UNI 6592	5	5
4	—	8mm Side Mount Retaining Ring	5	5
5	260746	Drum Access Cover Bolt M10 x 45mm Special	5	5
6	260798	Pin	1	—
	260834		—	1
7	—	12mm Retaining Ring External	2	2
8	260800	Drum Access Cover	1	—
	260835		—	1

## 7. Parts

### 7.3 40" Depth Components

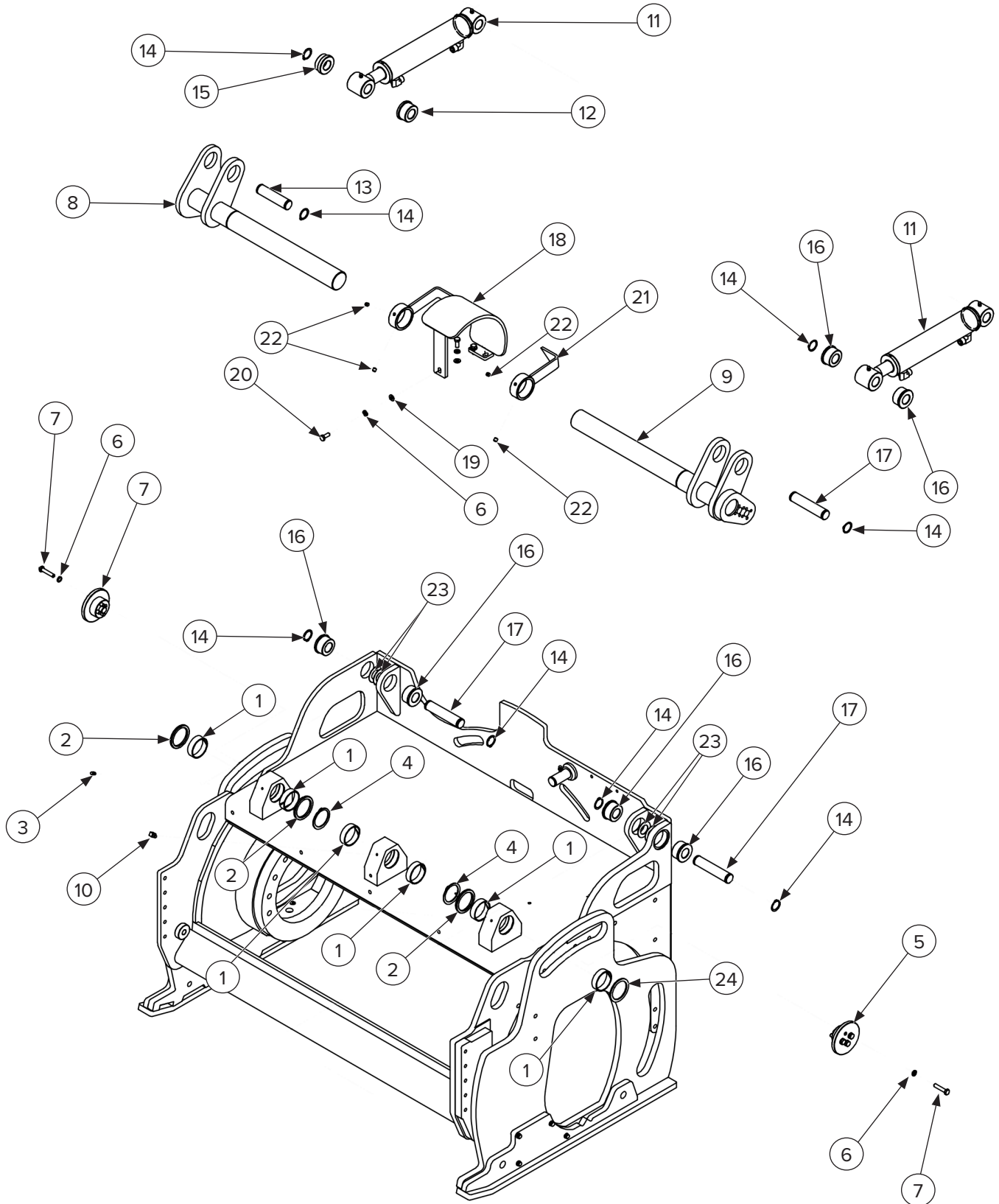

## 7. Parts

### 7.3 40" Depth Components Cont'd

ITEM	PART NUMBER	DESCRIPTION	QTY
1	260712	Depth Adjustment Shaft Guide Ring 50mm ID x 55mm OD x 15mm	6
2	260749	Depth Adjustment Shaft Spacer 3mm Thick	3
3	—	Grease Nipple	3
4	—	50mm Retaining Ring External	2
5	260731	Skid Plate Top Float Bushing	2
6	—	M8 Lock Washer	11
7	—	M8 x 1.25mm x 40mm Bolt Hex Head	8
8	—	Depth Adjustment Shaft Right Side	1
9	—	Depth Adjustment Shaft Left Side	1
10	—	Grease Nipple	1
11	260766	Depth Cylinder 50mm Bore x 30mm Rod x 180mm Stroke x 370mm Retracted Length	2
12	—	Spacer	1
13	—	Pin	1
14	—	25mm Retaining Ring External	8
15	—	Bush	1
16	—	Bush	6
17	—	Pin	3
18	260776	Depth Adjustment Indicator Plate	1
19	—	M8 Flat Washer UNI 6592	3
20	—	M8 x 1.25mm x 20mm Bolt Hex Head Fully Threaded	3
21	—	Depth Indicator Arm Left Side	1
22	—	M8 x 1.25mm x 8mm Set Screw Flat Tip	4
23	—	Depth Cylinder Spacer 5mm Thick 25mm ID x 44mm OD	4
24	260818	Depth Adjustment Shaft Spacer 3mm Thick	1

# 7. Parts

## 7.4 48" Depth Components

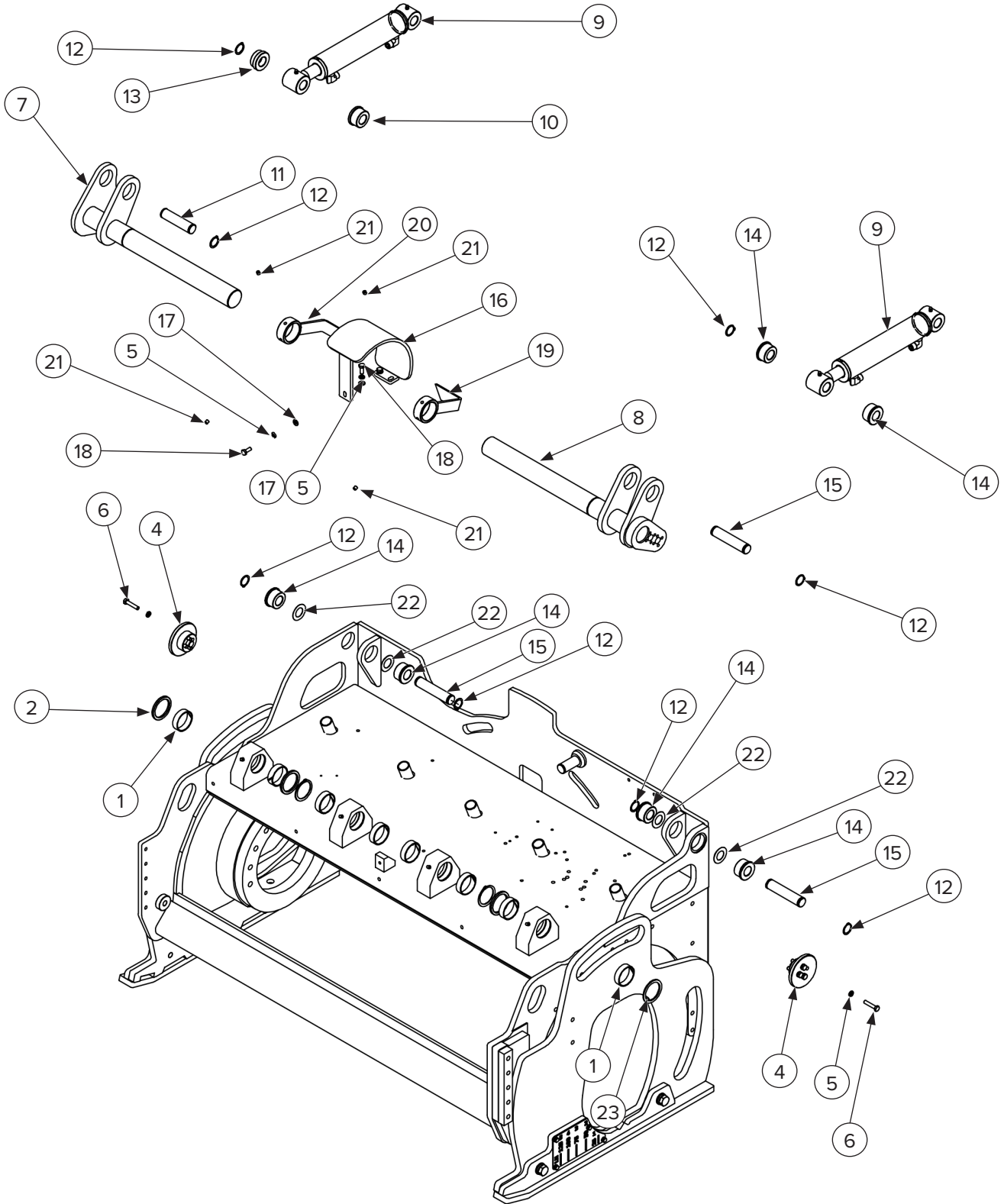

## 7. Parts

### 7.4 48" Depth Components Cont'd

ITEM	PART NUMBER	DESCRIPTION	QTY
1	260712	Depth Adjustment Shaft Guide Ring 50mm ID x 55mm OD x 15mm	8
2	260749	Depth Adjustment Shaft Spacer 3mm Thick	3
3	—	50mm Retaining Ring External	2
4	260731	Skid Plate Top Float Bushing	2
5	—	M8 Lock Washer	11
6	—	M8 x 1.25mm x 40mm Bolt Hex Head	8
7	—	Depth Adjustment Shaft Right Side	1
8	—	Depth Adjustment Shaft Left Side	1
9	260766	Depth Cylinder 50mm Bore x 30mm Rod x 180mm Stroke x 370mm Retracted Length	2
10	—	Spacer	1
11	—	Pin	1
12	—	25mm Retaining Ring External	8
13	—	Bush	1
14	—	Bush	6
15	—	Pin	3
16	260776	Depth Adjustment Indicator Plate	1
17	—	M8 Flat Washer UNI 6592	3
18	—	M8 x 1.25mm x 20mm Bolt Hex Head Fully Threaded	3
19	—	Depth Indicator Arm Left Side	1
20	—	Depth Indicator Arm Right Side	1
21	—	M8 x 1.25mm x 8mm Set Screw Flat Tip	4
22	—	Depth Cylinder Spacer 5mm Thick 25mm ID x 44mm OD	4
23	260818	Depth Adjustment Shaft Spacer 3mm THick	1

## 7. Parts

### 7.5 48" Tilting Components

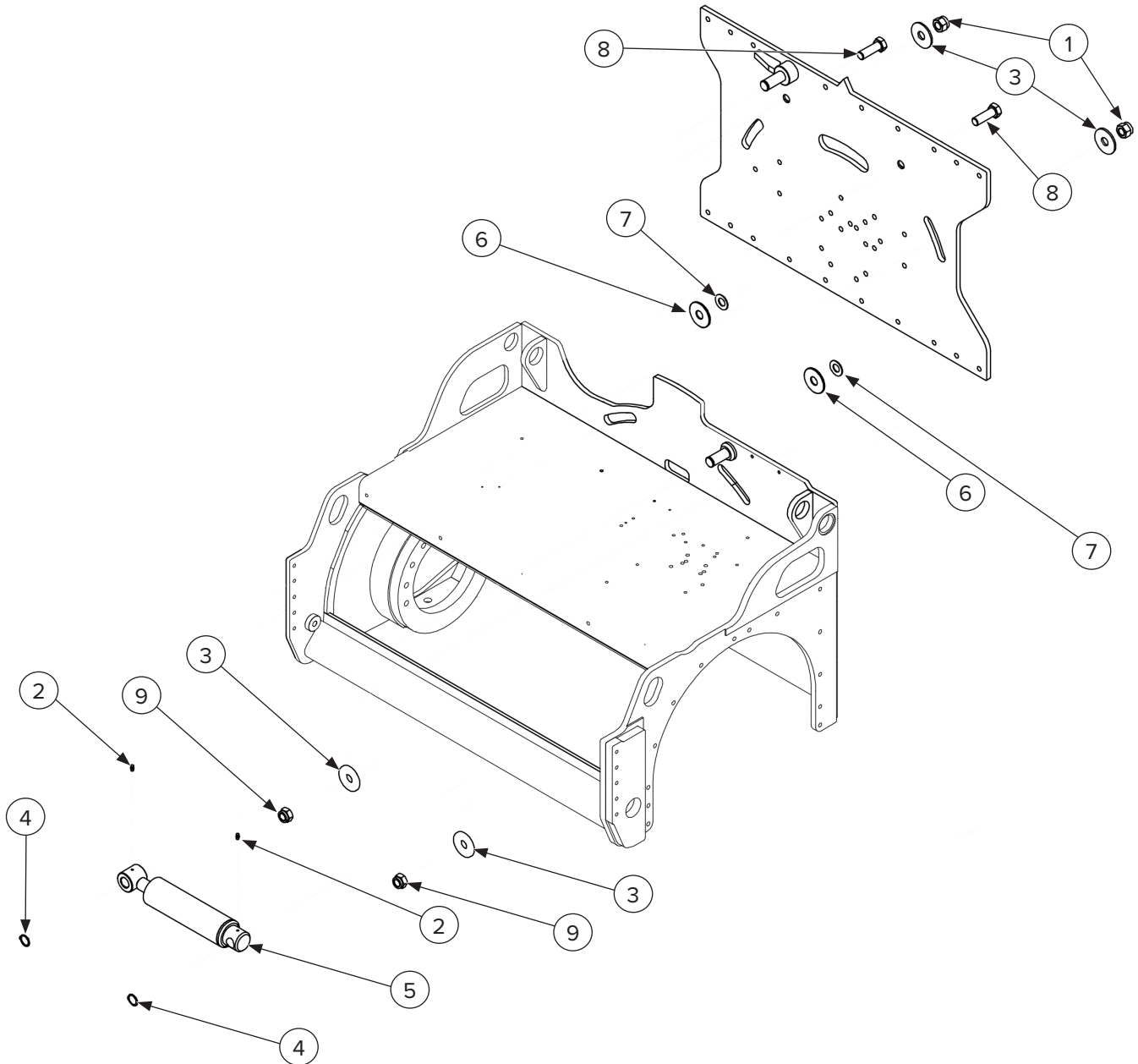

ITEM	PART NUMBER	DESCRIPTION	QTY
1	—	M20 x 2.5mm Nylock Nut DIN 982	2
2	—	Grease Nipple	2
3	—	5mm x M20 x 65mm Flat Washer Zinc Plated	4
4	—	25mm Retaining Ring External	2
5	—	Tilt Shock Absorber	1
6	—	Washer	2
7	—	Disc Spring 20mm ID	2
8	—	M20 x 2.5mm x 60mm Bolt Hex Head Fully Threaded	2
9	—	M20 x 2.5mm Nylock Nut DIN 985	2

## 7. Parts

### 7.6 Drum Components — Both Models

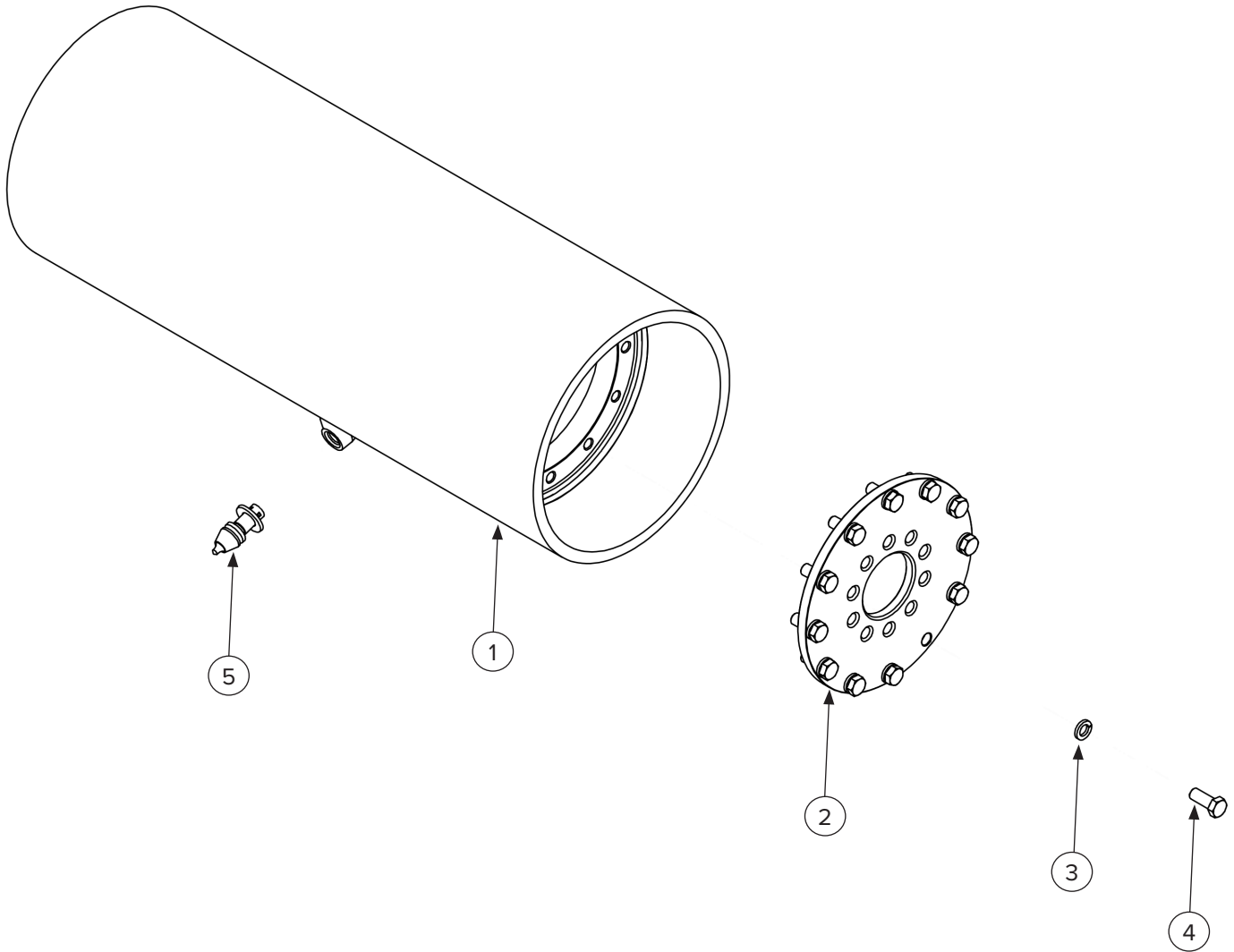

ITEM	PART NUMBER	DESCRIPTION	40" QTY	48" QTY
1	—	Drum Weldment	1	—
	—		—	1
2	260804	Motor to Drum Mount Flange	1	1
3	—	M16 Lock Washer	12	12
4	—	M16 x 2mm x 40mm Bolt Hex Head Fully Threaded	12	12
5	260000	Straight Tooth	78	90
	260001	Grooved Tooth		
	260004	Concrete Tooth		
	260006	Diamond PCD Tooth		
	260007	Smooth Tapered Asphalt Tooth		



## 7. Parts

### 7.7 Left Side Mount Components — Both Models

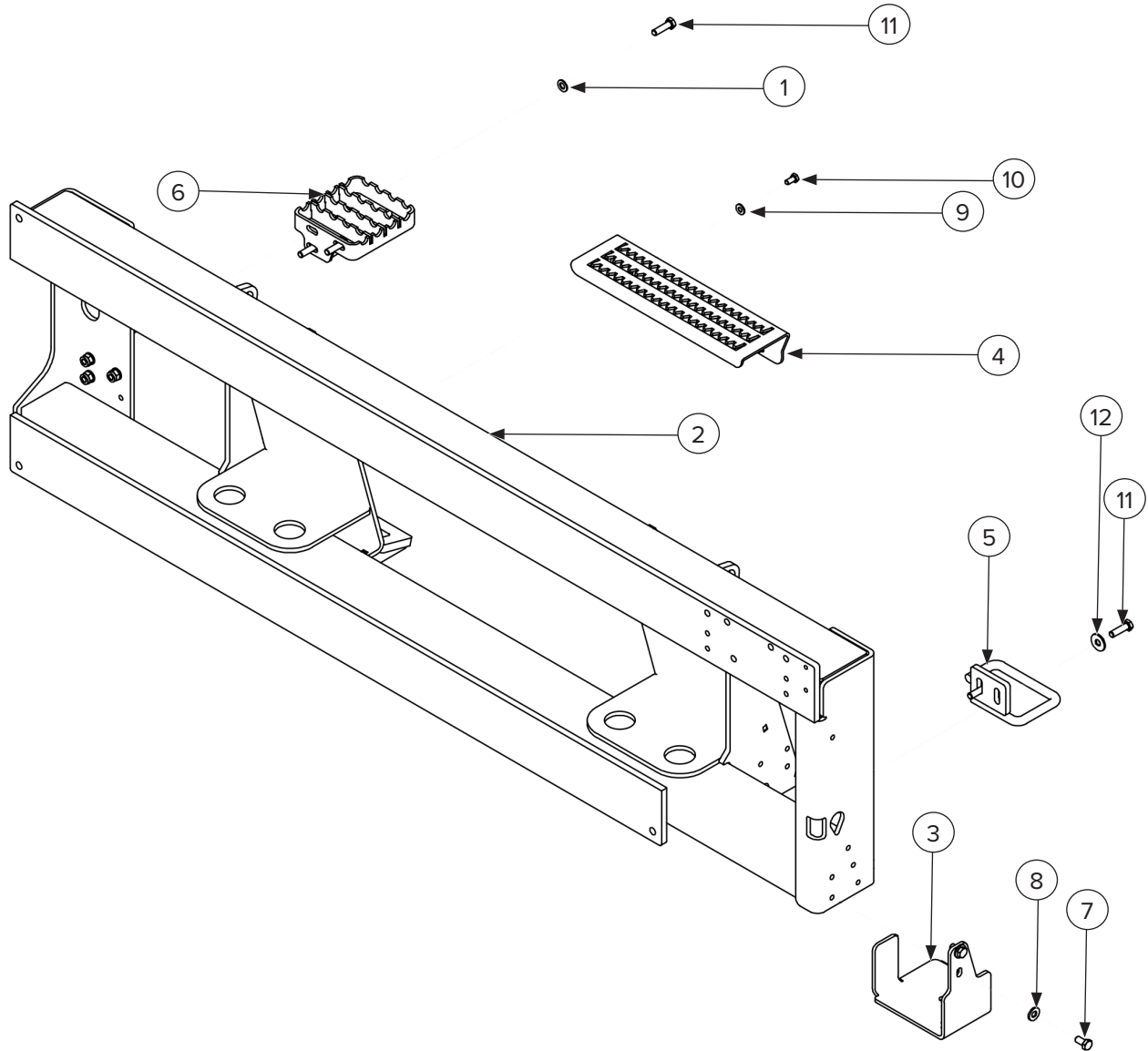

ITEM	PART NUMBER	DESCRIPTION	40" QTY	48" QTY
1	—	M10 Flat Washer UNI 6592	8	8
2	260782	Mount Weldment 1850mm Wide	1	1
3	260786	Hose Support Cover Plate	1	1
4	260730	Top Step Weldment	1	1
5	260725	Hose Guide Ring	1	1
6	260720	Side Step Weldment	1	1
7	—	M10 x 1.5mm x 20mm Bolt Hex Head Fully Threaded	2	2
8	—	M10 Spring Lock Washer DIN 6796	2	2
9	—	M8 Spring Lock Washer DIN 6796	2	2
10	—	M8 x 1.25mm x 16mm Bolt Hex Head Fully Threaded	2	2
11	—	M10 x 1.5mm x 35mm Bolt Hex Head Fully Threaded	5	5
12	—	2.5mm x M10 x 30mm Flat Washer UNI 6593	2	2

## 7. Parts

### 7.8 Motor Components

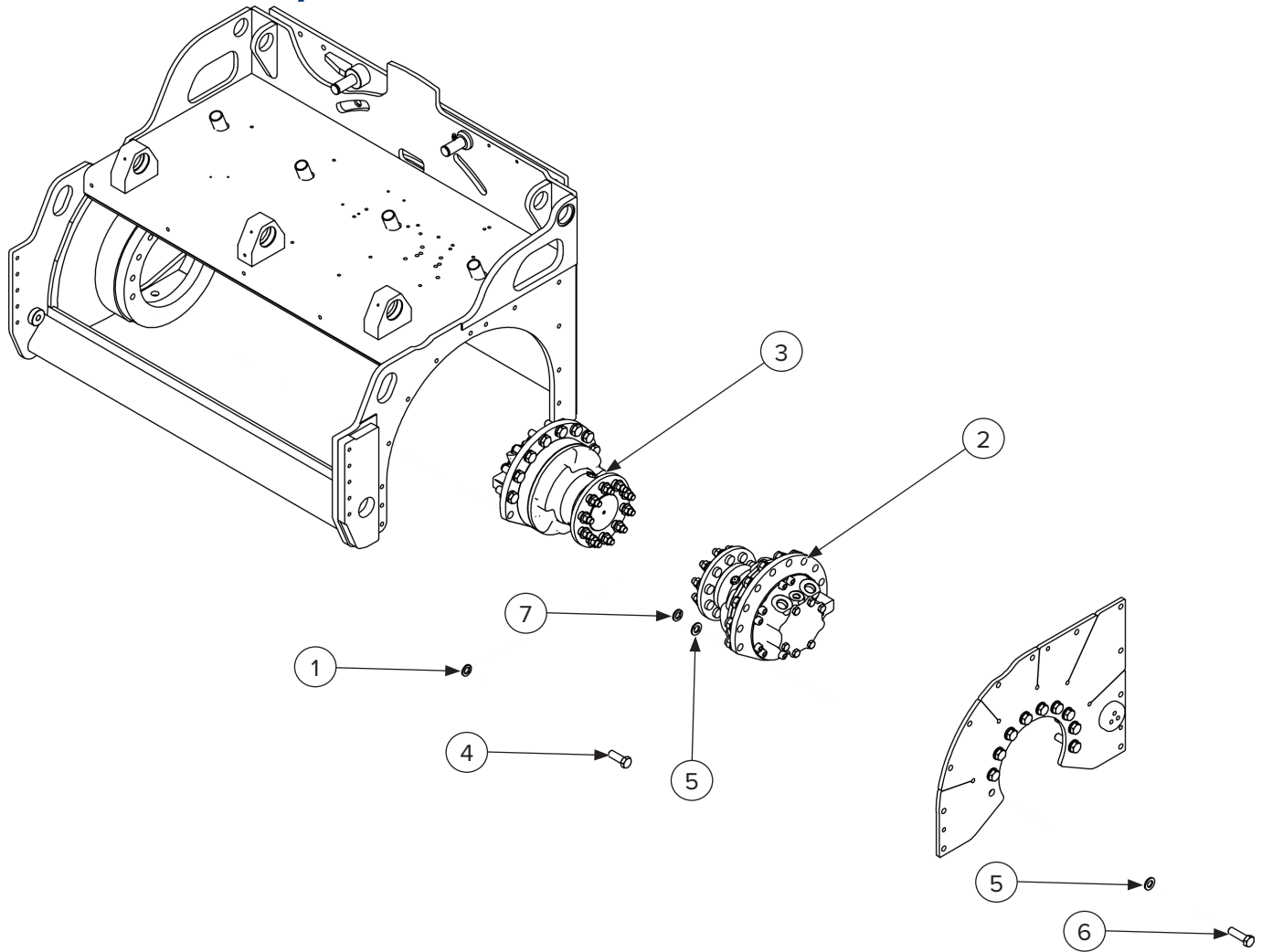

ITEM	PART NUMBER	DESCRIPTION	40" QTY	48" QTY
1	—	M16 Lock Washer	10	10
2	—	Motor	1	—
	—		—	1
3	—	Motor	1	1
4	—	M16 x 2mm x 45mm Bolt Hex Head Fully Threaded	10	10
5	—	M16 Flat Washer UNI 6592	20	20
6	—	M16 x 2mm x 55mm Bolt Hex Head	10	10
7	—	M16 x 2mm Nylock Nut DIN 982	10	10

## 7. Parts

### 7.9 Sideshift Components — Both Models

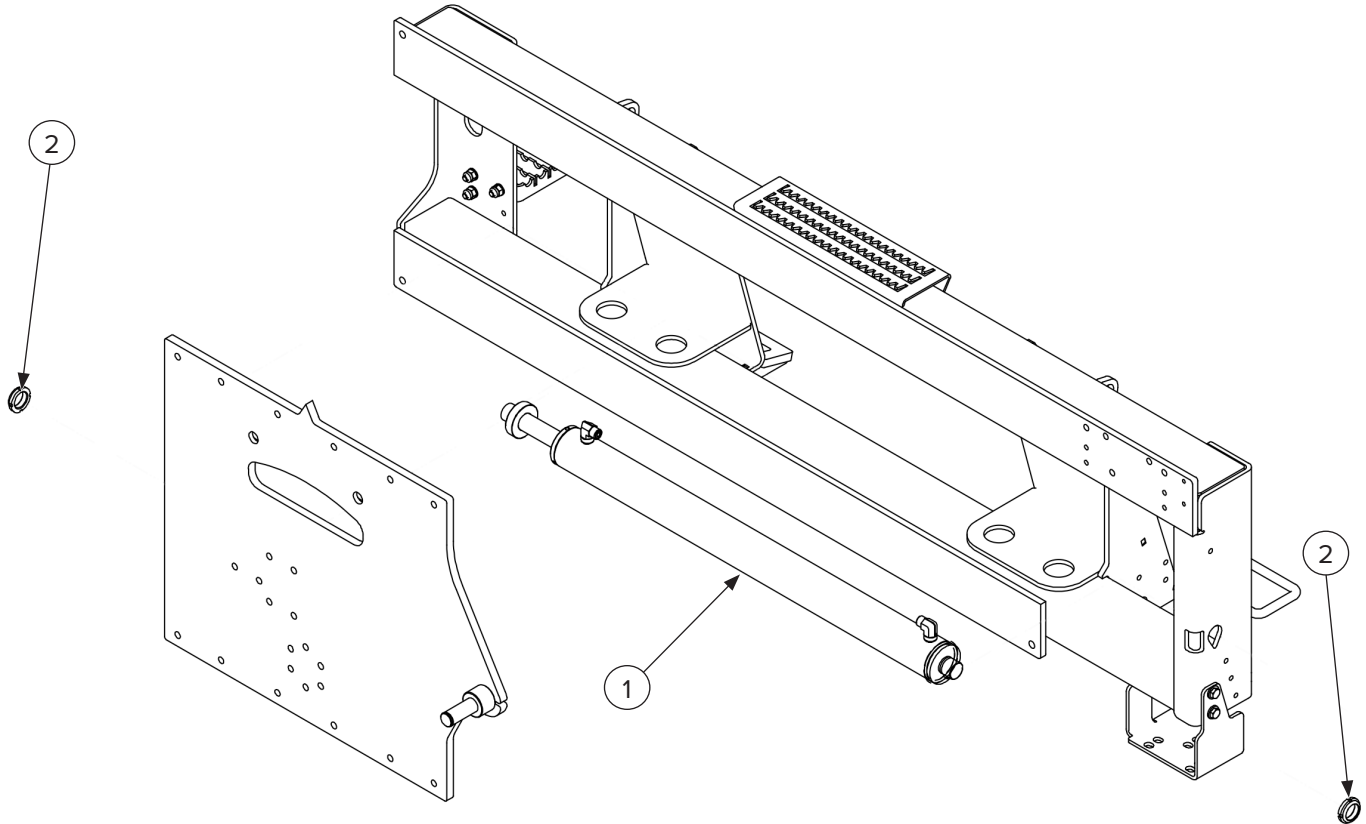

ITEM	PART NUMBER	DESCRIPTION	40" QTY	48" QTY
1	—	Sideshift Cylinder 60mm Bore x 30mm Rod x 557 Stroke x 913mm Retracted Length with 115mm Extra Rod Length	1	1
2	—	M30 x 1.5mm x 11mm Nut Nylon Insert Bearing Locknut	2	2

## 7. Parts

### 7.10 Machine Hoses Left Side — Both Models

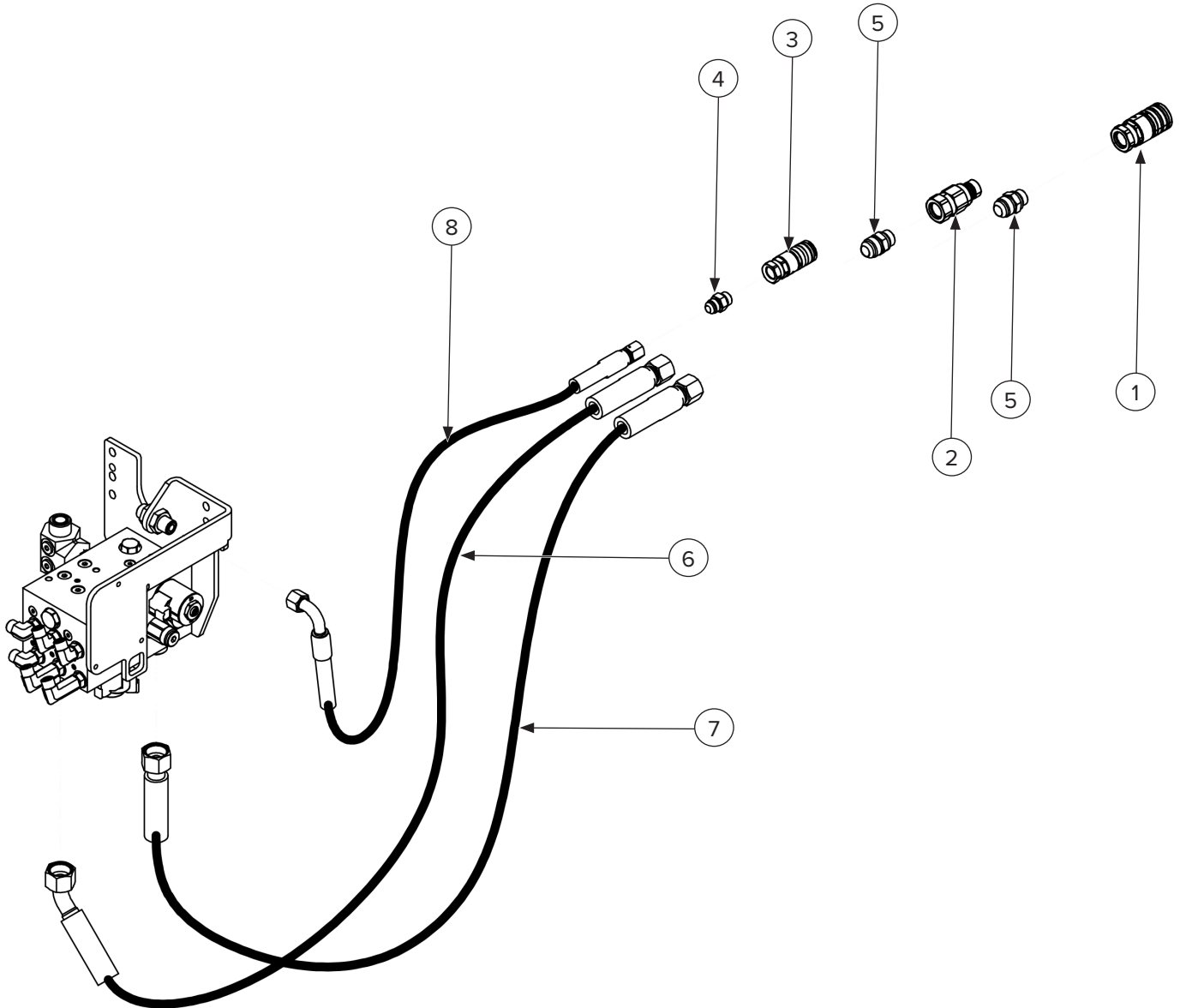

ITEM	PART NUMBER	DESCRIPTION	40" QTY	48" QTY
1	—	Quick Connection	1	1
2	—	Quick Connection	1	1
3	—	Quick Connection	1	1
4	295010-M08JIC-M08ORB	Hydraulic Straight Fitting Male #8 JIC x Male #8 O-Ring Boss	1	1
5	295010-M12JIC-M10ORB	Hydraulic Straight Fitting Male #12 JIC x Male #10 ORB	2	2
6	—	Hose	1	1
7	—	Hose	1	1
8	260787	Case Drain Machine Hose 2600mm OAL 1/2" ID 90 Degree Female #8 O-Ring Face Seal Swivel to Female #8 JIC Swivel	1	1

# 7. Parts

## 7.11 G4 Block Components — Both Models

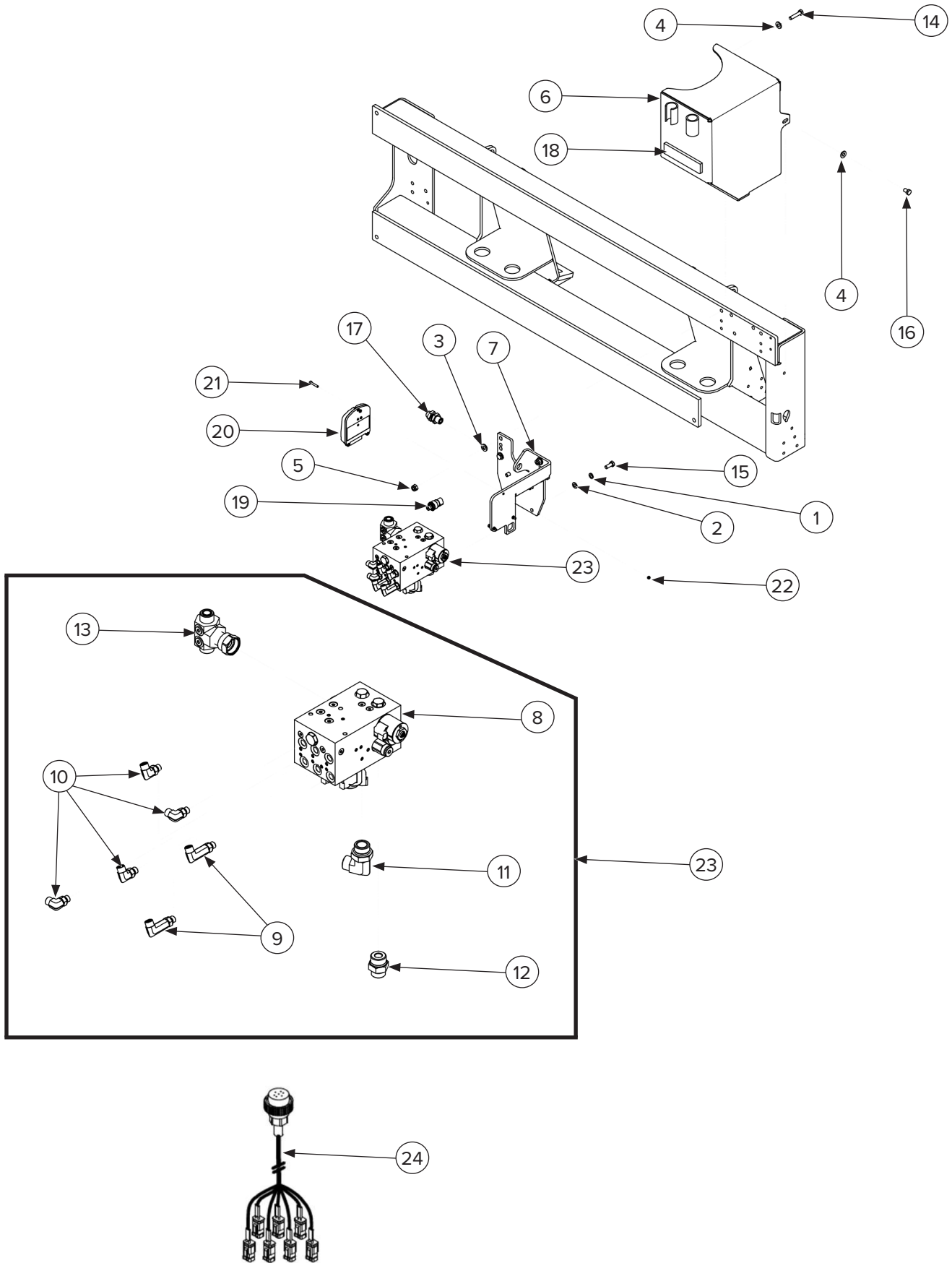

## 7. Parts

### 7.11 G4 Block Components – Both Models Cont'd

ITEM	PART NUMBER	DESCRIPTION	40" QTY	48" QTY
1	—	M10 Lock Washer	4	4
2	—	M10 Flat Washer UNI 6592	4	4
3	—	M14 Flat Washer UNI 6592	2	2
4	—	M10 Spring Lock Washer DIN 6796	5	5
5	—	M10 x 1.5mm Nylock Nut DIN 982	2	2
6	260771	Manifold Valve Block Cover	1	1
7	260777	Diverter Valve Mount Bracket	1	1
8	260788	Manifold Valve Block	1	1
9	—	Hydraulic 90 Degree Fitting Male #6 O-Ring Face Seal x Male #6 O-Ring Boss Long	2	2
10	—	Hydraulic 90 Degree Fitting Male #6 ORFS x Male #6 O-Ring Boss	4	4
11	—	Hydraulic 90 Degree Fitting Male #12 ORFS x Male #16 O-Ring Boss	1	1
12	295010-M12FS-M16ORB	Hydraulic Straight Fitting Male #12 O-Ring Face Seal x Male #16 O-Ring Boss	1	1
13	260773	Transducer Tee Fitting with #6 ORB Ports Male #12 ORFS to Male #12 ORFS to Female #16 ORFS	1	1
14	—	M10 x 1.5mm x 45mm Bolt Hex Head Fully Threaded	2	2
15	—	M10 x 1.5mm x 25mm Bolt Hex Head Fully Threaded	4	4
16	—	M10 x 1.5mm x 16mm Bolt Hex Head Fully Threaded	1	1
17	295010-M08FS-M08FSBH	Hydraulic Straight Fitting Male #8 O-Ring Face Seal x Male #8 Bulkhead O-Ring Face Seal	1	1
18	260789	Adhesive Foam Strip 40mm x 10mm x 165mm Long	1	1
19	260774	Pressure Sensor 3-Pin Connector	1	1
20	260790	Electronic Control Unit	1	1
21	—	Screw	3	3
22	—	M5 x 0.8mm Nylock Nut DIN 985	3	3
23	260791	Manifold Valve Block Assembly with Fittings	1	1
24	—	Cable	1	1

# 7. Parts

## 7.12 Hydraulic Motor Components — Both Models

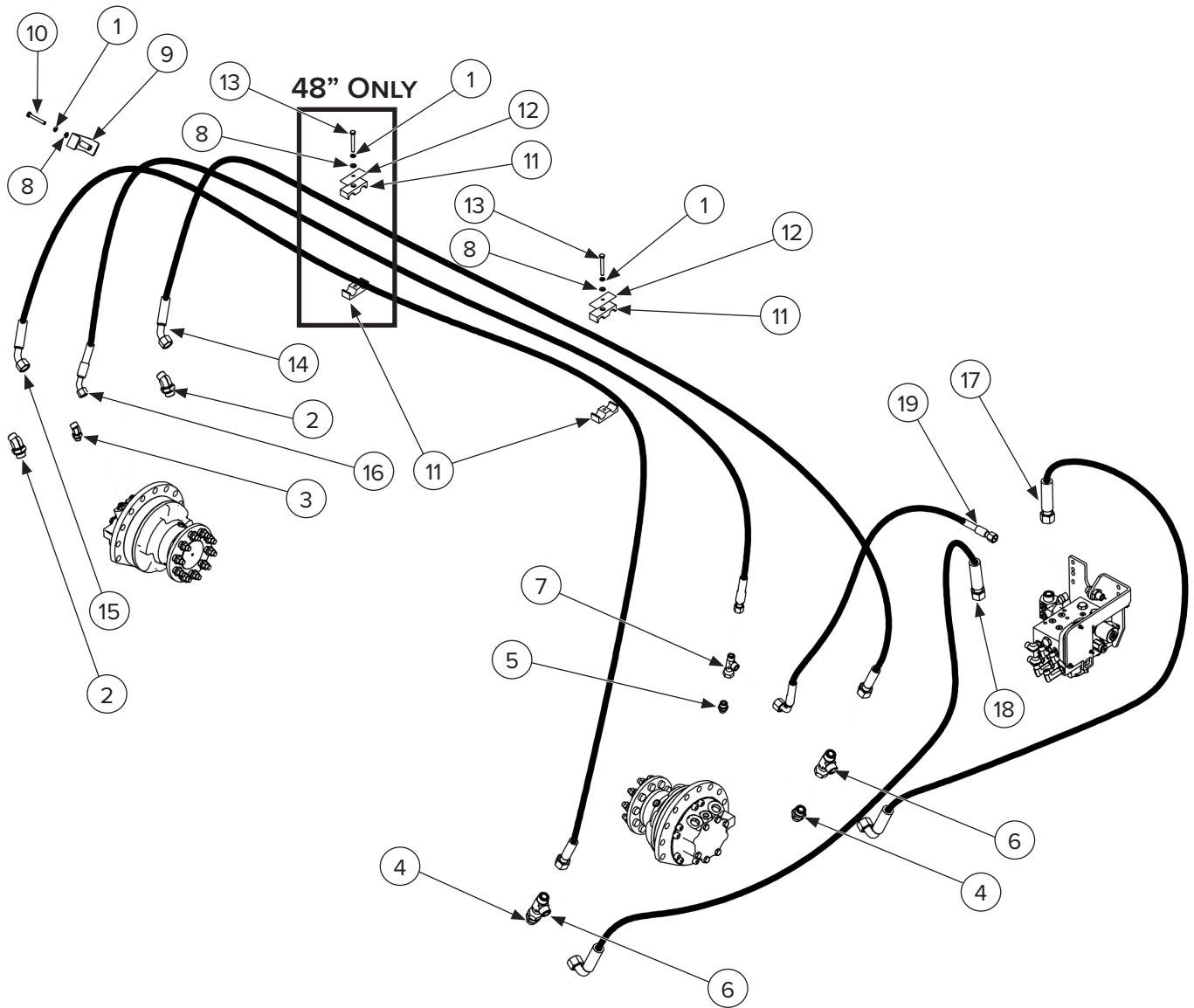

40" MODEL

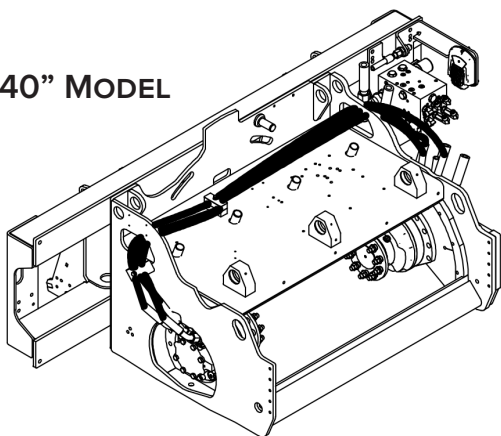

48" MODEL

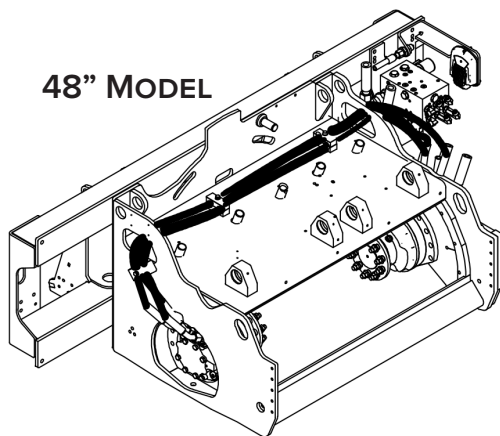

## 7. Parts

### 7.12 Hydraulic Motor Components — Both Models Cont'd

ITEM	PART NUMBER	DESCRIPTION	40" QTY	48" QTY
1	—	M8 Lock Washer	2	3
2	—	Hydraulic 45 Degree Fitting Male #10 O-Ring Face Seal to Male #12 BSPP	2	2
3	295020-M08FS-M06BSPPW	Hydraulic 45 Degree Fitting Male #8 O-Ring Face Seal x Male #6 BSPP Washer Seal	1	1
4	295010-M12FS-M12BSPPW	Hydraulic Straight Fitting Male #12 O-Ring Face Seal x Male #12 BSPP Washer Seal	2	2
5	295010-M08FS-M06BSPPW	Hydraulic Straight Fitting Male #8 O-Ring Face Seal x Male #6 BSPP Washer Seal	1	1
6	295050-M12FS-F12FS-M12FS	Hydraulic Tee Fitting Male #12 O-Ring Face Seal x Female #12 O-Ring Face Seal Swivel x Male #12 O-Ring Face Seal	2	2
7	295050-M08FS-F08FS-M08FS	Hydraulic Tee Fitting Male #8 O-Ring Face Seal x Female #8 O-Ring Face Seal Swivel x Male #8 O-Ring Face Seal	1	1
8	—	M8 Flat Washer UNI 6592	3	3
9	260819	Right Side Motor Hose Clamp Plate	1	1
10	—	M8 x 1.25mm x 60mm Bolt Hex Head Fully Threaded	1	1
11	—	Double Hose Clamp Plastic Collar for Motor Hoses	2	4
12	—	Double Hose Clamp Bolt Plate	1	2
13	—	M8 x 1.25mm x 65mm Bolt Hex Head Fully Threaded	1	2
14	—	Flexible Hose	1	—
	—		—	1
15	—	Flexible Hose	1	—
	—		—	1
16	260821	Right Side Motor Case Drain Hose 1780mm OAL 1/2" ID Straight Female #8 O-Ring Face Seal Swivel to 45 Degree Female #8 O-Ring Face Seal Swivel	1	—
	—	Right Side Motor Case Drain Hose 2030mm OAL 1/2" ID 45 Degree Female #8 O-Ring Face Seal Swivel to 45 Degree Female #8 O-Ring Face Seal Swivel	—	1
17	—	Flexible Hose	1	1
18	—	Flexible Hose	1	1
19	—	Left Side Motor Case Drain Hose with Sleeve 1100mm OAL 1/2" ID 90 Degree Female #10 O-Ring Face Seal Swivel to Straight Female #8 O-Ring Face Seal Swivel	1	—
	—	Left Side Motor Case Drain Hose with Sleeve 1150mm OAL 1/2" ID 90 Degree Female #8 O-Ring Face Seal Swivel to Straight Female #8 O-Ring Face Seal Swivel	—	1



## 7. Parts

### 7.13 Hydraulic Sideshift Components — Both Models

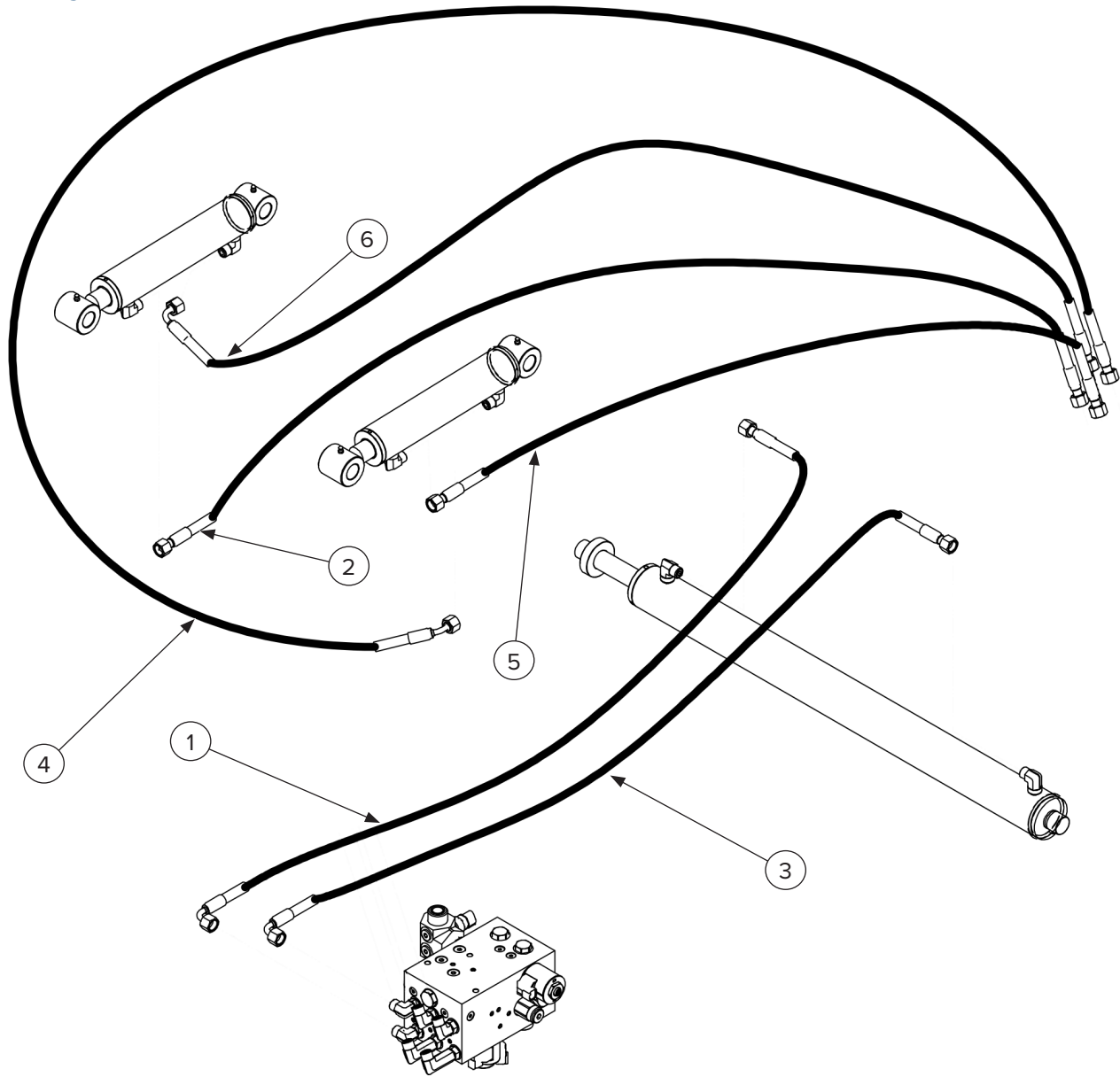

ITEM	PART NUMBER	DESCRIPTION	40" QTY	48" QTY
1	260822	Sideshift Cylinder Retract Hose with Sleeve 750mm OAL 1/4" ID Straight Female #6 O-Ring Face Seal x 90 Degree Female #6 O-Ring Face Seal	1	1
2	260823	Depth Cylinder Left Retract Hose with Sleeve 2500mm OAL 1/4" ID Straight Female #6 O-Ring Face Seal x Straight Female #6 O-Ring Face Seal	1	—
	260837	Depth Cylinder Right Retract Hose with Sleeve 2700mm OAL 1/4" ID Straight Female #6 O-Ring Face Seal x Straight Female #6 O-Ring Face Seal	—	1
3	260824	Sideshift Cylinder Extend Hose with Sleeve 440mm OAL 1/4" ID 90 Degree Female #6 O-Ring Face Seal x Straight Female #6 O-Ring Face Seal	1	1
4	260831	Depth Cylinder Left Extend Hose with Sleeve 1440mm OAL 1/4" ID 90 Degree Female #6 O-Ring Face Seal x Straight Female #6 O-Ring Face Seal	1	1
5	260832	Depth Cylinder Left Retract Hose with Sleeve 1530mm OAL 1/4" ID Straight Female #6 O-Ring Face Seal x Straight Female #6 O-Ring Face Seal	1	1
6	260833	Depth Cylinder Right Extend Hose with Sleeve 2400mm OAL 1/4" ID Straight Female #6 O-Ring Face Seal x 90 Degree Female #6 O-Ring Face Seal	1	—
	260838	Depth Cylinder Right Extend Hose with Sleeve 2520mm OAL 1/4" ID 90 Degree Female #6 O-Ring Face Seal x Straight Female #6 O-Ring Face Seal	—	1

# 7. Parts

## 7.14 40" Water Kit Components

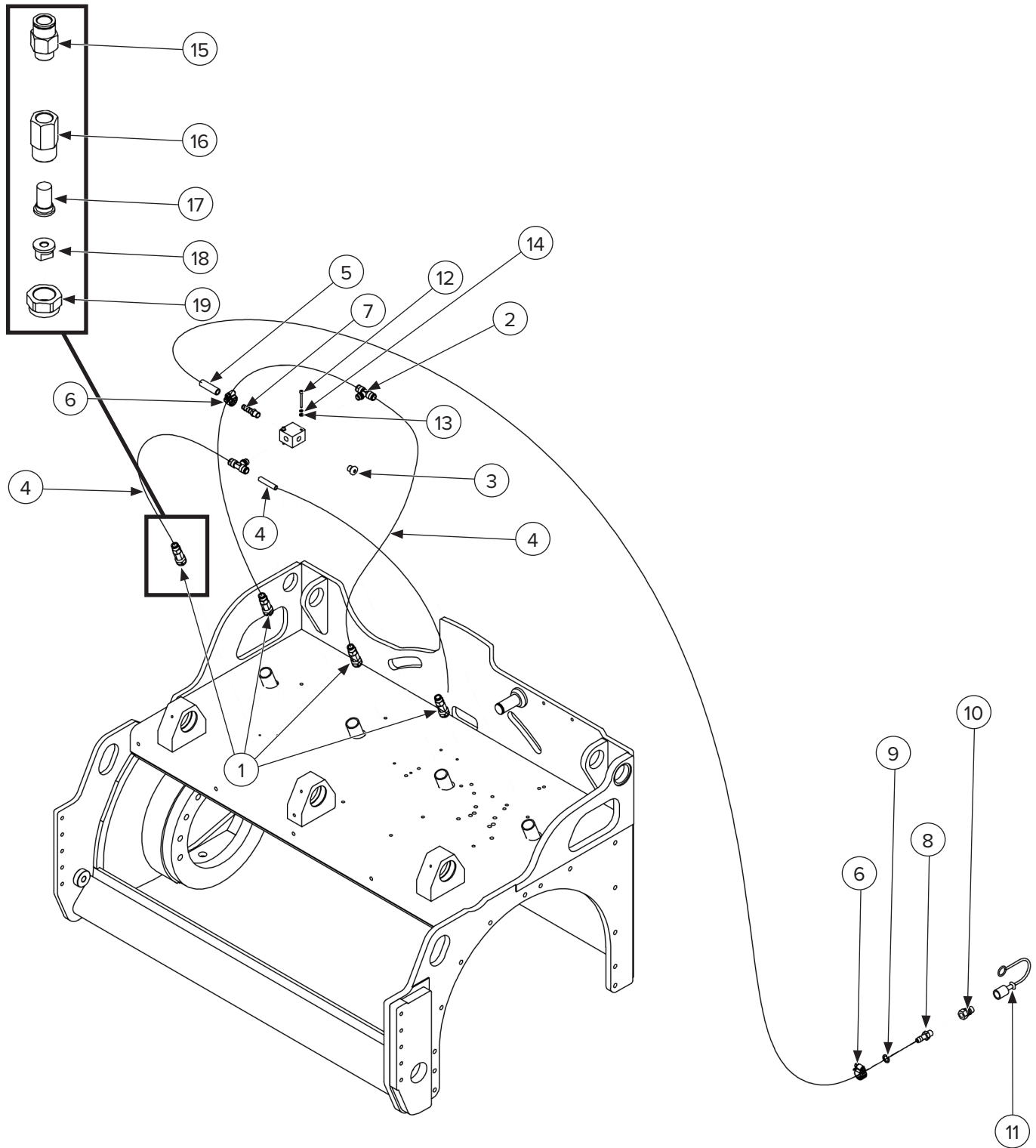

## 7. Parts

### 7.14 40" Water Kit Components Cont'd

ITEM	PART NUMBER	DESCRIPTION	QTY
1	260767	Water Kit Nozzle Assembly	4
2	260810	Water Kit Manifold Tee	2
3	—	Plug	1
4	260783	Water Kit Hose 7.5mm ID x 10mm OD	1
5	260784	Water Kit Hose 10mm ID x 15mm OD	1
6	—	Hose Clamp 10mm – 16mm OD	2
7	—	Joint	1
8	—	Joint	1
9	—	Copper Sealing Washer 1/4" BSPP	1
10	—	Quick Connection	1
11	—	Water Kit Coupler Dust Cap	1
12	—	M4 x 0.7mm x 40mm Bolt Socket Head	2
13	—	M4 Flat Washer UNI 6592	2
14	—	M4 Lock Washer	2
15	—	Joint	1
16	260765	Water Kit Nozzle Body	1
17	—	Water Kit Nozzle Filter	1
18	—	Water Kit Nozzle Spray Tip 95 Degree Spread 0.66mm Orifice	1
19	—	Ring Nut	1

## 7. Parts

### 7.13 24" Tool Kit

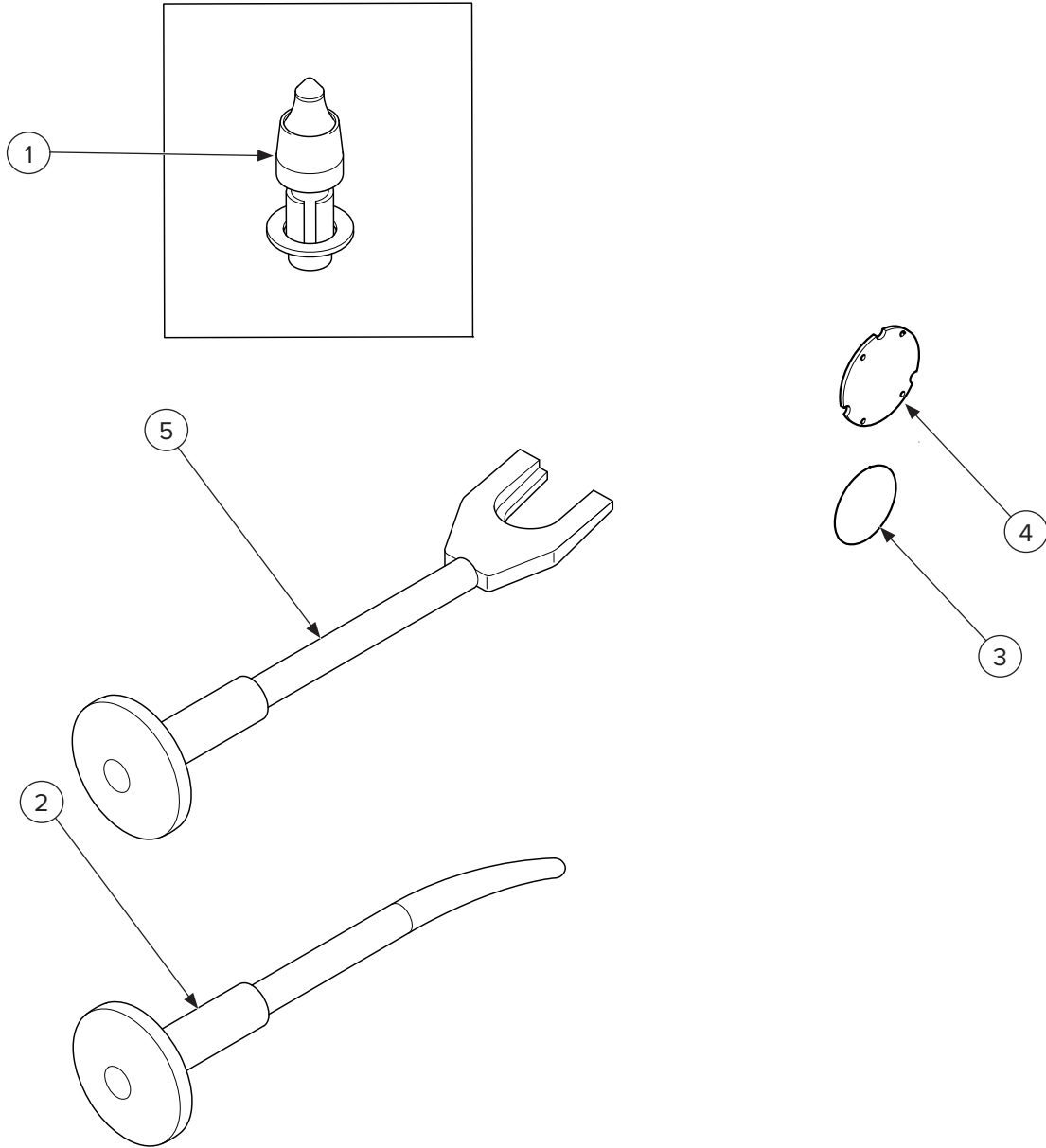

ITEM	PART NUMBER	DESCRIPTION	QTY
1	260007	Smooth Tapered Asphalt Tooth	10
2	—	Tooth Removal Pick Tool	1
3	260764	Motor Case Overpressure Safety Cover O-Ring	1
4	260772	Motor Case Overpressure Safety Cover Plate	1
5	—	Tooth Removal Forked Tool	1

# 7. Parts

## 7.15 Safety Decals



## 7. Parts

### 7.15 Safety Decals Cont'd

ITEM	PART NUMBER	DESCRIPTION	QTY
1	BD-060	Decal, Blue Diamond Attachments 2.4375" x 2.375"	2
2	BD-114	Decal, Blue Diamond Attachments, Diamond Shape 10.35" x 8.08"	1
3	BD-092	Decal, Warranty Registration QR Code 1.5" x 2"	1
4	BD-001	Decal, Read Owners Manual 3" x 3"	1
5	BD-123	Decal, High Pressure Fluid Hazard 3" x 3"	1
6	BD-004	Decal, Grease All Fittings Every 8 Hours 2" x 4"	1
7	260756	Decal, Angle Indicator 0 – 8 Degrees 148mm x 65mm	1
8	260705	Decal, Crush Hazard – Stay Clear	2
9	—	Decal, Depth Indicator 0" – 5", 0mm – 130mm	1
10	260708	Decal, Lift Point	4
11	260701	Decal, Wear Personal Protective Equipment (PPE)	1
12	260703	Decal, Read Manual	1
13	260706	Decal, Turn Off and Remove Key Before Maintenance	1
14	260702	Decal, Flying Objects – Stay Clear	2
15	260704	Decal, Stay Clear of Rotating Parts	1
16	260709	Decal, Rotating Drum	2



### CAUTION



Always heed the warnings on the plates and decals/stickers. Failure to do so may result in death or serious injury. Make sure the plates and decals/stickers are always in place and legible. If this is not the case, affix or replace them, obtaining materials required from Blue Diamond®.

## 8. Specifications

### 8.1 Attachment Specifications

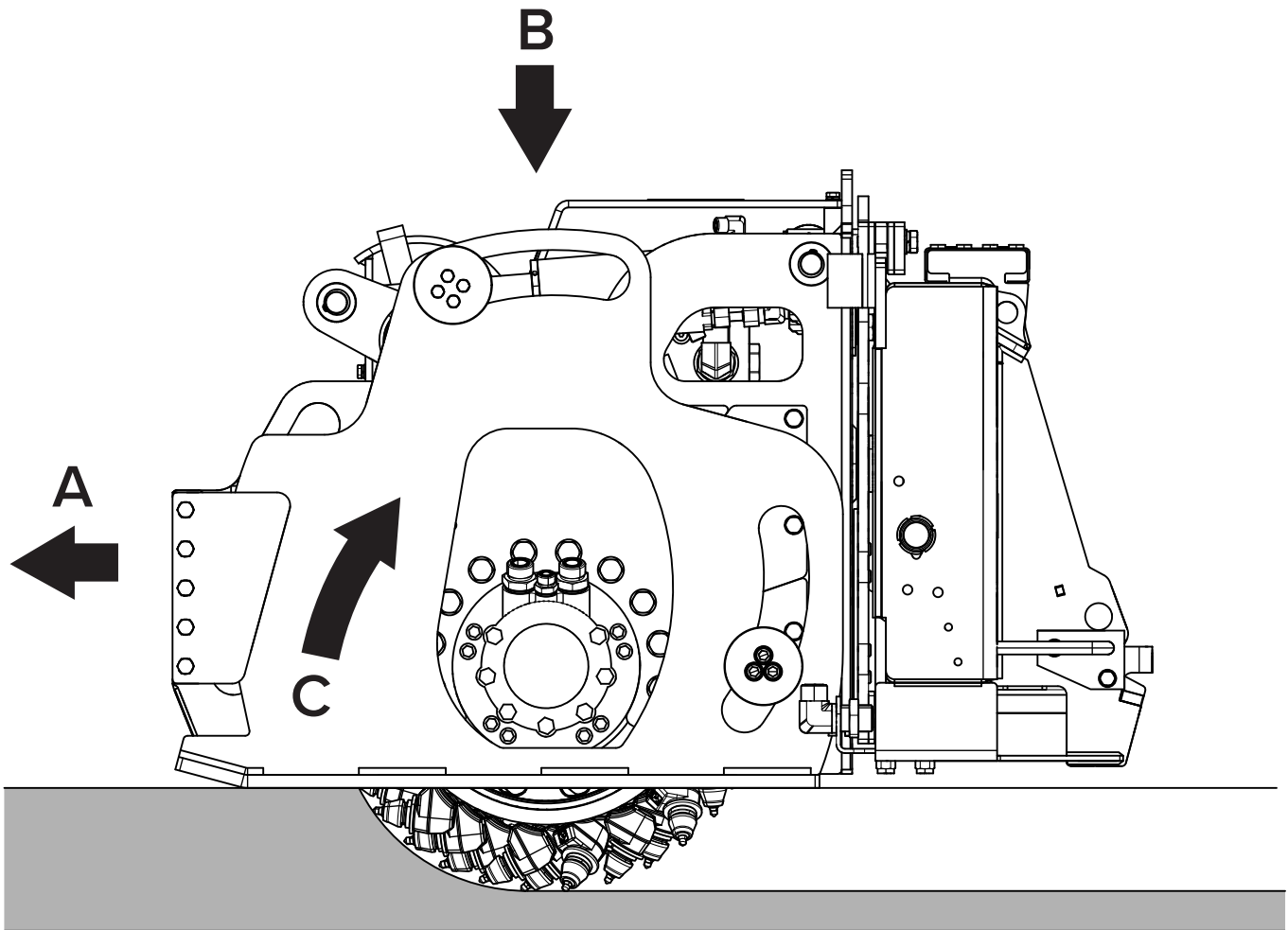

#### ALL MODELS

A	Forward Movement
B	Ground Gripping Strength
C	Rotation Direction of the Cutter Drum

## 8. Specifications

### 8.1 Attachment Specifications Cont'd

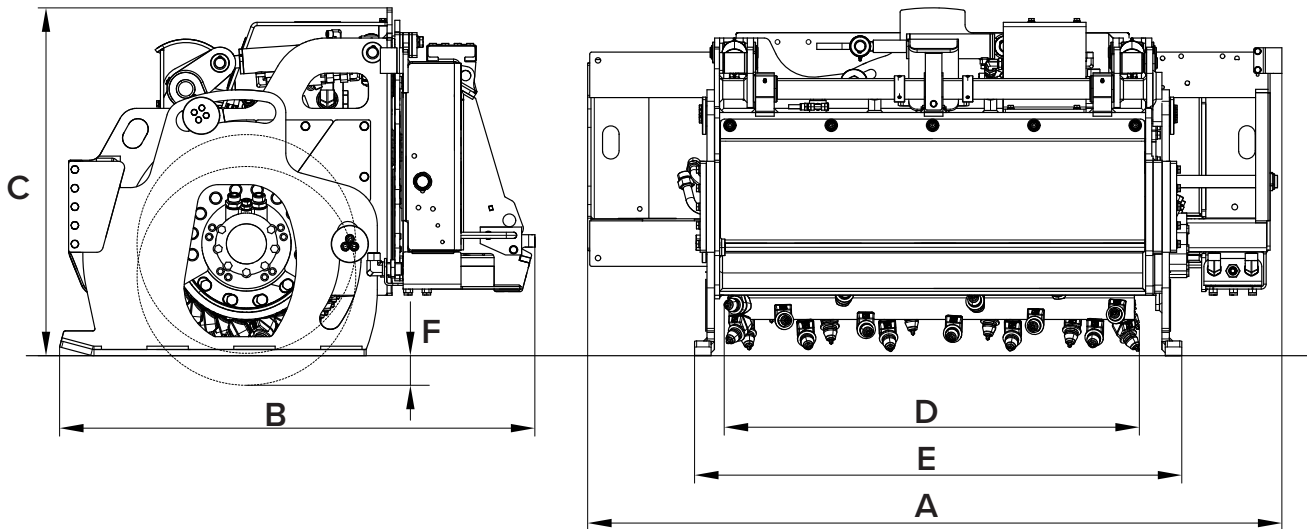

DESCRIPTION	160956	160957
Overall Width (A)	66 in. 1680 mm	
Overall Length (B)	45 in. 1140 mm	
Overall Height (C)	33 in. 830 mm	
Cutting Width (D)	40 in. 1000 mm	48 in. 1200 mm
Chassis Width (E)	46.5 in. 1181 mm	
Cutting Depth (F)	0–5 in. 0–130 mm	
Maximum Tilt, Left & Right	8°	



## 8. Specifications

### 8.1 Attachment Specifications Cont'd

TECHNICAL CHARACTERISTIC	160956	160957
Operating Pressure	2321 – 4500 PSI 160 – 310 bar	2321 – 4500 PSI 160 – 310 bar
Oil Flow	29–50 GPM 110–190 l/min	17–30 GPM 65–115 l/min
Drum Revs	150–230 rpm	150–230 rpm
Max. Hydraulic Motor Power	60 kW	60 kW
	82 HP	82 HP
Weight*	2400 lbs 1090 kg	2660 lbs 1210 kg

\*Standard equipment configuration without accessories and universal coupling.

#### Example of how to calculate the hydraulic motor power:

##### *Imperial Units*

$$\frac{Q \text{ (GPM)} \times P \text{ (PSI)}}{1,714} = A \text{ (HP)}$$

##### *Metric Units*

$$\frac{Q \text{ (l / min)} \times P \text{ (bar)}}{450} = A \text{ (kW)}$$

##### Key

Q = Capacity P = Pressure A = Power

**NOTE:** The capacity and pressure rates stated in the equation above must be measured at exactly the same time, using a precision tool. The measurement must be carried out by a skilled person.

## 8. Specifications

### 8.2 Torque Specifications

#### Standard Hardware and Lock Nuts

BOLT TYPE	CLASS 4.8		CLASS 8.8 OR 9.8		CLASS 10.9		CLASS 12.9		
	Size	Lubricated	Dry	Lubricated	Dry	Lubricated	Dry	Lubricated	Dry
M6		4.8 N•m	6 N•m	9 N•m	11 N•m	13 N•m	17 N•m	15 N•m	19 N•m
		3.5 lbf•ft	4.5 lbf•ft	6.5 lbf•ft	8.5 lbf•ft	9.5 lbf•ft	12 lbf•ft	11.5 lbf•ft	14.5 lbf•ft
M8		12 N•m	15 N•m	22 N•m	28 N•m	32 N•m	40 N•m	37 N•m	47 N•m
		8.5 lbf•ft	11 lbf•ft	16 lbf•ft	20 lbf•ft	24 lbf•ft	30 lbf•ft	28 lbf•ft	35 lbf•ft
M10		23 N•m	29 N•m	43 N•m	55 N•m	63 N•m	80 N•m	75 N•m	95 N•m
		17 lbf•ft	21 lbf•ft	32 lbf•ft	40 lbf•ft	47 lbf•ft	60 lbf•ft	55 lbf•ft	70 lbf•ft
M12		40 N•m	50 N•m	75 N•m	95 N•m	110 N•m	140 N•m	130 N•m	165 N•m
		29 lbf•ft	37 lbf•ft	55 lbf•ft	70 lbf•ft	80 lbf•ft	105 lbf•ft	95 lbf•ft	120 lbf•ft
M14		63 N•m	80 N•m	120 N•m	150 N•m	175 N•m	225 N•m	205 N•m	260 N•m
		47 lbf•ft	60 lbf•ft	88 lbf•ft	110 lbf•ft	130 lbf•ft	165 lbf•ft	150 lbf•ft	190 lbf•ft
M16		135 N•m	175 N•m	260 N•m	330 N•m	375 N•m	475 N•m	440 N•m	560 N•m
		100 lbf•ft	125 lbf•ft	195 lbf•ft	250 lbf•ft	275 lbf•ft	350 lbf•ft	325 lbf•ft	410 lbf•ft
M18		135 N•m	175 N•m	260 N•m	330 N•m	375 N•m	475 N•m	440 N•m	560 N•m
		100 lbf•ft	125 lbf•ft	195 lbf•ft	250 lbf•ft	275 lbf•ft	350 lbf•ft	325 lbf•ft	410 lbf•ft
M20		190 N•m	240 N•m	375 N•m	475 N•m	530 N•m	675 N•m	625 N•m	800 N•m
		140 lbf•ft	180 lbf•ft	275 lbf•ft	350 lbf•ft	400 lbf•ft	500 lbf•ft	460 lbf•ft	580 lbf•ft
M22		260 N•m	330 N•m	510 N•m	650 N•m	725 N•m	925 N•m	850 N•m	1075 N•m
		190 lbf•ft	250 lbf•ft	375 lbf•ft	475 lbf•ft	540 lbf•ft	675 lbf•ft	625 lbf•ft	800 lbf•ft
M24		330 N•m	425 N•m	650 N•m	825 N•m	925 N•m	1150 N•m	1075 N•m	1350 N•m
		250 lbf•ft	310 lbf•ft	475 lbf•ft	600 lbf•ft	675 lbf•ft	850 lbf•ft	800 lbf•ft	1000 lbf•ft
M27		490 N•m	625 N•m	950 N•m	1200 N•m	1350 N•m	1700 N•m	1600 N•m	2000 N•m
		360 lbf•ft	450 lbf•ft	700 lbf•ft	875 lbf•ft	1000 lbf•ft	1250 lbf•ft	1150 lbf•ft	1500 lbf•ft
M30		675 N•m	850 N•m	1300 N•m	1650 N•m	1850 N•m	2300 N•m	2150 N•m	2700 N•m
		490 lbf•ft	625 lbf•ft	950 lbf•ft	1200 lbf•ft	1350 lbf•ft	1700 lbf•ft	1600 lbf•ft	2000 lbf•ft
M33		900 N•m	1150 N•m	1750 N•m	2200 N•m	2500 N•m	3150 N•m	2900 N•m	3700 N•m
		675 lbf•ft	850 lbf•ft	1300 lbf•ft	1650 lbf•ft	1850 lbf•ft	2350 lbf•ft	2150 lbf•ft	2750 lbf•ft
M36		1150 N•m	1450 N•m	2250 N•m	2850 N•m	3200 N•m	4050 N•m	3750 N•m	4750 N•m
		850 lbf•ft	1075 lbf•ft	1650 lbf•ft	2100 lbf•ft	2350 lbf•ft	3000 lbf•ft	2750 lbf•ft	3500 lbf•ft

## 8. Specifications

### 8.2 Torque Specifications Cont'd

#### Tightening Torques for Hose Fittings

DASH SIZE	BSPP DIAMETER	TORQUE
#4	1/4"	35 N•m
		26 lbf•ft
#6	3/8"	70 N•m
		52 lbf•ft
#8	1/2"	100 N•m
		74 lbf•ft
#12	3/4"	190 N•m
		140 lbf•ft
#16	1"	300 N•m
		221 lbf•ft
#20	1 1/4"	330 N•m
		243 lbf•ft
#24	1 1/2"	400 N•m
		295 lbf•ft

DASH SIZE	"W" (inch) DIAMETER	TORQUE
#6	9/16"	30 N•m
		22 lbf•ft
#8	3/4"	50 N•m
		37 lbf•ft
#10	7/8"	70 N•m
		52 lbf•ft
#12	1 1/16"	100 N•m
		74 lbf•ft
#14	1 3/16"	130 N•m
		96 lbf•ft
#16	1 5/16"	145 N•m
		107 lbf•ft
#20	1 5/8"	190 N•m
		140 lbf•ft
#24	1 7/8"	240 N•m
		177 lbf•ft

## 8. Specifications

### 8.2 Torque Specifications Cont'd

#### Tightening Torques for Hoses

With ORFS Fittings

DASH SIZE	"W" (inch) DIAMETER	TORQUE
#4	9/16"	25 N•m
		18 lbf•ft
#6	11/16"	40 N•m
		30 lbf•ft
#8	13/16"	55 N•m
		41 lbf•ft
#10	1"	100 N•m
		74 lbf•ft
#12	1 3/16"	125 N•m
		92 lbf•ft
#16	1 7/16"	165 N•m
		122 lbf•ft
#20	1 11/16"	200 N•m
		148 lbf•ft
#24	2"	245 N•m
		181 lbf•ft

With JIC 37° Fittings

DASH SIZE	"W" (inch) DIAMETER	TORQUE
#6	9/16"	30 N•m
		22 lbf•ft
#8	3/4"	50 N•m
		37 lbf•ft
#10	7/8"	70 N•m
		52 lbf•ft
#12	1 1/16"	100 N•m
		74 lbf•ft
#14	1 3/16"	130 N•m
		96 lbf•ft
#16	1 5/16"	145 N•m
		107 lbf•ft
#20	1 5/8"	190 N•m
		140 lbf•ft
#24	1 7/8"	240 N•m
		177 lbf•ft

With BSPP Fittings

DASH SIZE	"W" (inch) DIAMETER	TORQUE
#4	1/4"	15 N•m
		11 lbf•ft
#6	3/8"	28 N•m
		21 lbf•ft
#8	1/2"	60 N•m
		44 lbf•ft
#10	5/8"	70 N•m
		52 lbf•ft
#12	3/4"	110 N•m
		81 lbf•ft
#16	1"	140 N•m
		103 lbf•ft
#20	1 1/4"	190 N•m
		140 lbf•ft
#24	1 1/2"	245 N•m
		181 lbf•ft



## Warranty

### MANUFACTURER'S LIMITED WARRANTY

BLUE DIAMOND® ATTACHMENTS, a manufacturer of quality attachments, warrants new BLUE DIAMOND® ATTACHMENTS products and/or attachments at the time of delivery to the original purchaser, to be free from defects in material and workmanship when properly set up and operated in accordance with the recommendations set forth by BLUE DIAMOND® ATTACHMENTS, LLC.

BLUE DIAMOND® ATTACHMENTS liability for any defect with respect to accepted goods shall be limited to repairing the goods at a BLUE DIAMOND® ATTACHMENTS designated location or at an authorized dealer location, or replacing them, as BLUE DIAMOND® ATTACHMENTS shall elect. The above shall be in accordance with BLUE DIAMOND® ATTACHMENTS warranty adjustment policies. BLUE DIAMOND® ATTACHMENTS obligation shall terminate twelve (12) months for the Extreme Duty Series 2 Cold Planer after the delivery of the goods to original purchaser.

This warranty shall not apply to any machine or attachment which shall have been repaired or altered outside the BLUE DIAMOND® ATTACHMENTS factory or authorized BLUE DIAMOND® ATTACHMENTS dealership or in any way so as in BLUE DIAMOND® ATTACHMENTS judgment, to affect its stability or reliability, nor which has been subject to misuse, negligence or accident beyond the company recommended machine rated capacity.

### WARRANTY CLAIM

To submit a warranty claim, a claim must be filed with BLUE DIAMOND® ATTACHMENTS before work is performed. The BLUE DIAMOND® PRODUCT SUPPORT TEAM will advise repairs and applicable parts exchanges. Tampering with the failed part may void the warranty. This warranty does not include freight or delivery charges incurred when returning machinery for servicing. Dealer mileage, service calls, and pickup/delivery charges are the customers' responsibility.

### EXCLUSIONS OF WARRANTY

Except as otherwise expressly stated herein, BLUE DIAMOND® ATTACHMENTS makes no representation or warranty of any kind, expressed or implied, AND MAKES NO WARRANTY OF MERCHANTABILITY IN RESPECT TO ITS MACHINERY AND/OR ATTACHMENTS ARE FIT FOR ANY PARTICULAR PURPOSE. BLUE DIAMOND® ATTACHMENTS shall not be liable for incidental or consequential damages for any breach or warranty, including but not limited to inconvenience, rental of replacement equipment, loss of profits or other commercial loss. Upon purchase, the buyer assumes all liability for all personal injury and property resulting from the handling, possession, or use of the goods by the buyer.

No agent, employee, or representative of BLUE DIAMOND® ATTACHMENTS has any authority to bind BLUE DIAMOND® ATTACHMENTS to any affirmation, representation, or warranty concerning its machinery and/or attachments except as specifically set forth herein.

This warranty policy supersedes any previous documents. Please see [bluediamondattachments.com/warranty-policies](http://bluediamondattachments.com/warranty-policies) for the most up to date warranty information.

**NOTE:** Blue Diamond® Attachments is a trademark of BLUE DIAMOND® ATTACHMENTS



**QUALITY | DEPENDABILITY | INTEGRITY**

Blue Diamond® Attachments  
4512 Anderson Road, Knoxville, TN 37918  
888-376-7027