

# Extreme Duty Series 2 Cold Planer 40" & 48"

Operation and Maintenance Manual

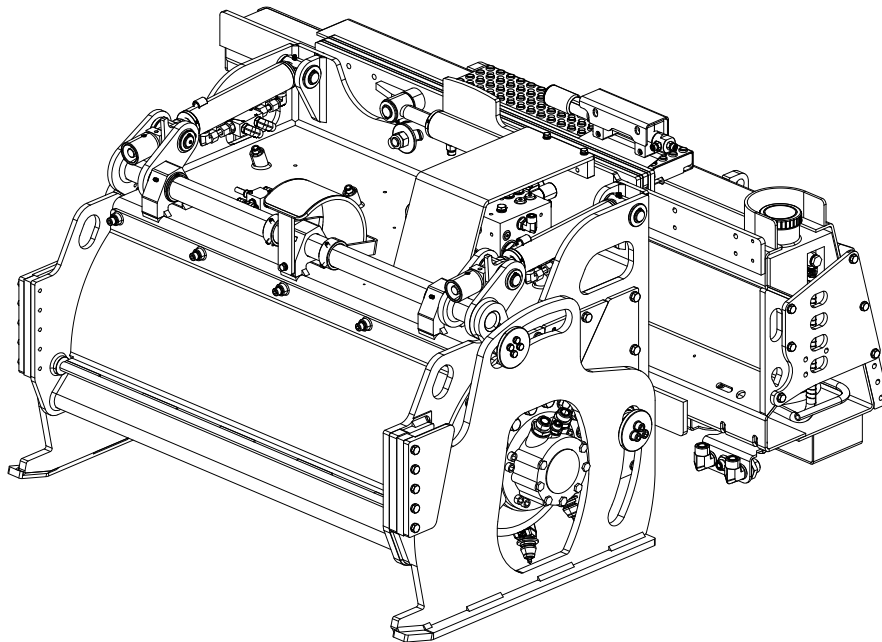

160956, 160957

Register your  
**WARRANTY**  
within 30 days  
of purchase



888-376-7027 | [BlueDiamondAttachments.com](http://BlueDiamondAttachments.com)



BD-092

Thank you for your decision to purchase a Blue Diamond® Extreme Duty Series 2 Cold Planer. To ensure maximum performance of your equipment, it is mandatory that you thoroughly study the Operator's manual and follow the recommendations. Proper operation and maintenance are essential to maximize equipment life and prevent personal injury.

Operate and maintain this equipment in a safe manner and in accordance with all applicable local, state, and federal codes, regulations and /or laws. Follow all on-product labeling and instructions.

Make sure that all personnel have read this Operator's Manual and thoroughly understand safe and correct operating, installation and maintenance procedures.

Blue Diamond® is continually working to improve its products. Blue Diamond® reserves the right to make any improvements or changes as deemed practical and possible without incurring any responsibility or obligation to make any changes or additions to equipment sold previously.

Although great care has been taken to ensure the accuracy of this publication, Blue Diamond® makes no warranty or guarantee of any kind, written or expressed, implied or otherwise with regard to the information contained within this manual. Blue Diamond® assumes no responsibility for any errors that may appear in this manual and shall not be liable under any circumstances for incidental, consequential or punitive damages in connection with, or arising from the use of this manual.

Keep this manual available for frequent reference. All new operators or owners must review the manual before using the equipment and annually thereafter. Contact your Blue Diamond® Attachments Dealer for assistance, information, or additional copies of the manual. Contact [www.bluediamondattachments.com](http://www.bluediamondattachments.com) or call 888-376-7027 for a complete list of dealers in your area.

## Serial Number Location:

Please record attachment information in the space provided for future reference.



Model Number: \_\_\_\_\_

Serial Number: \_\_\_\_\_

Dealer Name: \_\_\_\_\_

Dealer Number: \_\_\_\_\_

Date of Purchase: \_\_\_\_\_

The serial number plate is located on the right side of the mount as shown above.

Always use your serial number when requesting information or when ordering parts.

**NOTE:** The directions left, right, front, and rear, as mentioned throughout this manual, are as viewed from the operator's position.

# Table of Contents

---

1. Introduction.....	4	5.8 <i>Spare Parts &amp; Accessories</i> .....	31
1.1 <i>Attachment Identification</i> .....	4	5.9 <i>Troubleshooting</i> .....	32
1.2 <i>About this Attachment</i> .....	5	6. Wire Harness Control Guide.....	33
1.3 <i>Attachment Model Numbers</i> .....	5	6.1 <i>Warning</i> .....	33
2. Safety.....	6	6.2 <i>Universal Controller</i> .....	33
2.1 <i>General Safety Information</i> .....	6	6.3 <i>Bobcat</i> .....	34
2.2 <i>Operators</i> .....	7	6.4 <i>CASE &amp; New Holland</i> .....	34
2.3 <i>Safety Guidelines</i> .....	8	6.5 <i>CAT D XPS / XHP</i> .....	35
3. Transport.....	11	6.6 <i>CAT D3 XPS / XHP X XE</i> .....	35
3.1 <i>Delivering &amp; Unloading</i> .....	11	6.7 <i>Gehl / Manitou / Mustang</i> .....	36
3.2 <i>Handling, Transportation, &amp; Lifting</i> .....	11	6.8 <i>JCB / Volvo — Post 10 / 2010</i> .....	36
4. Use.....	13	6.9 <i>JCB / Volvo — New Series 3.x</i> .....	37
4.1 <i>Preliminary Checks</i> .....	13	6.10 <i>John Deere</i> .....	37
4.2 <i>How to Enter &amp; Exit the Skid Steer</i> .....	13	6.11 <i>Kubota</i> .....	38
4.3 <i>Machine/Prime Mover Coupling</i> .....	14	6.12 <i>Takeuchi</i> .....	38
4.4 <i>Machine/Prime Mover Hydraulic Connection</i> .....	15	6.13 <i>Wacker Neuson</i> .....	39
4.5 <i>Connecting Flat-Faced Quick Couplings</i> .....	16	6.14 <i>Yanmar</i> .....	39
4.6 <i>Machine/Prime Mover Connections Disengage</i> .....	16	7. Specifications.....	40
4.7 <i>Machine/Prime Mover Disconnect</i> .....	17	7.1 <i>Attachment Specifications</i> .....	40
4.8 <i>Starting Up</i> .....	18	7.2 <i>Torque Specifications</i> .....	43
4.9 <i>Preparing the Equipment for Use</i> .....	18	Warranty.....	47
4.10 <i>Cutting Unit Sideshift Function</i> .....	19		
4.11 <i>Floating Tilt Function</i> .....	19		
4.12 <i>Planing Depth</i> .....	20		
4.13 <i>Work Start Procedure</i> .....	21		
4.14 <i>Planing in Parallel Passes</i> .....	22		
4.15 <i>Water Spraying Unit (Optional)</i> .....	23		
4.16 <i>Removable Right Skid Shoe (Optional)</i> .....	23		
4.17 <i>Stopping the Equipment in Normal Conditions</i> .....	23		
4.18 <i>Emergency Stops</i> .....	23		
4.19 <i>Parking</i> .....	24		
4.20 <i>Preparing the Unit for Long Periods of Inactivity</i> ...	24		
4.21 <i>Recommissioning the Unit after Long Periods of Inactivity</i> .....	24		
4.22 <i>Disposal</i> .....	24		
5. Maintenance.....	25		
5.1 <i>Service Schedule</i> .....	25		
5.2 <i>Every Hour</i> .....	26		
5.3 <i>Every 8 Hours</i> .....	28		
5.4 <i>Every 50 Hours</i> .....	29		
5.5 <i>Every 100 Hours</i> .....	29		
5.6 <i>Every 200 Hours</i> .....	30		
5.7 <i>When Required</i> .....	30		

# 1. Introduction

## 1.1 Attachment Identification

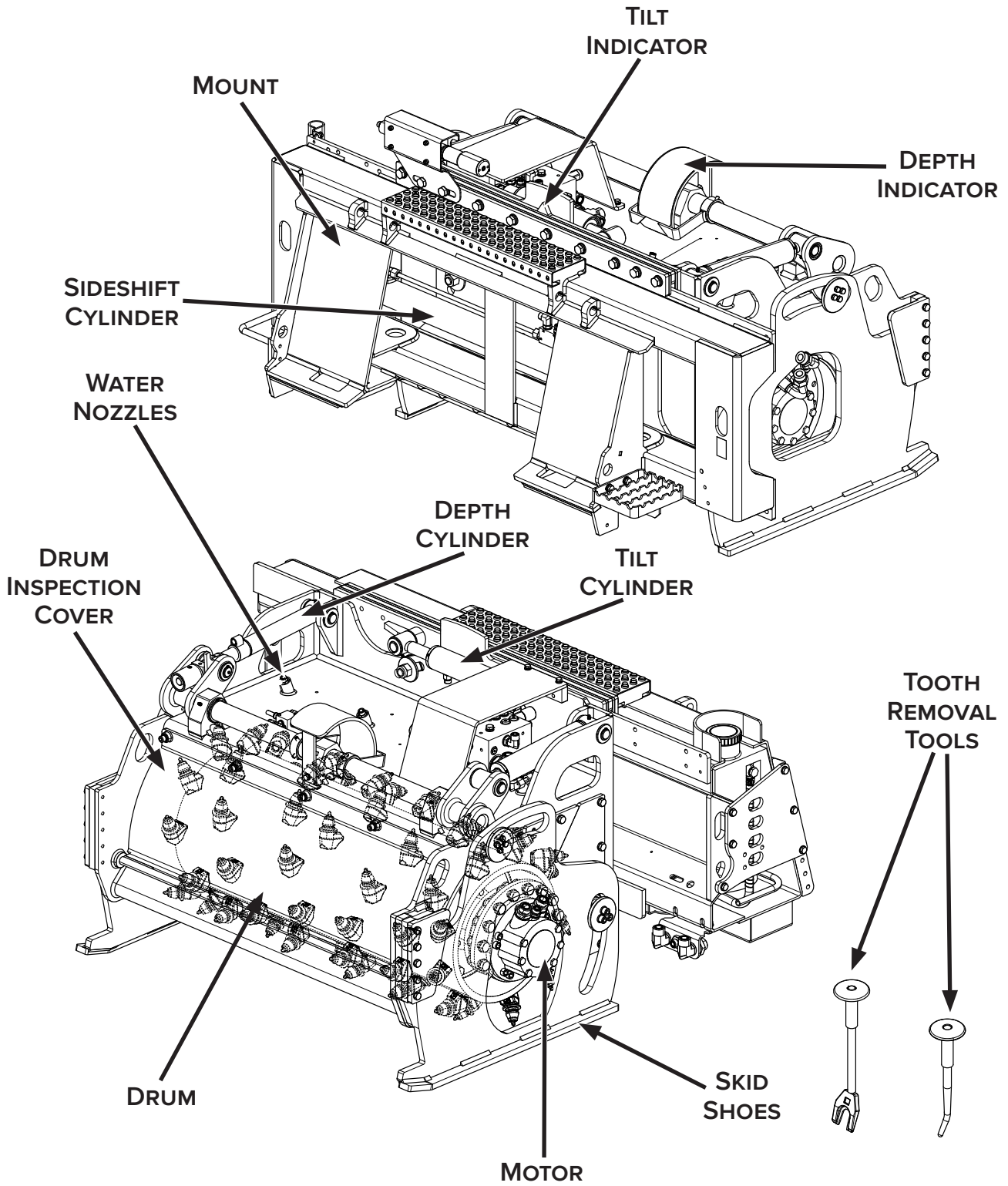



# 1. Introduction

## 1.2 About this Attachment

### Intended Use

The Extreme Duty Series 2 Cold Planer is designed to be connected to a skid steer to perform variable depth scarification works of hard and compact materials, such as asphalt, rock, concrete, and sediments.

The Extreme Duty Series 2 Cold Planer can self-level for variable depth planing for asphalt, rock, concrete, sediment, gravel, etc. This attachment's drum rotates and cuts material from the bottom upwards, crushing and removing it with the hard, metal teeth located on its outer surface. The drum rotation is driven by a fixed displacement hydraulic motor that is directly connected and powered by the machine, such as a skid steer, through hoses and quick couplings.

The skid shoes hold the planed material. They rest on the ground and are held in place by two (2) independently controlled hydraulic cylinders. These determine the planing depth and allow for different setting on the left and right side.

To facilitate planing on a surface that is not parallel to the surface the prime mover's wheels are resting on, the attachment tilts to follow the contour of the planing space.

The crushed material is left on the ground.

The attachment can be shifted to the right to plane up to and beyond the edge of the prime mover.

An optional water spraying system, which can be fitted with the tank and electric pump mounted on the prime mover, sprays water towards the teeth of the drum. This significantly reduces the dust produced during planing.

The attachment is mounted solidly onto the machine with a universal skid steer mount. The hydraulic power is also supplied by the machine, and the connections used are hydraulic quick couplings.

All functions of the equipment are controlled by the existing controls on the machine, sometimes with the addition of a specific control panel, but this is also installed on the machine and not the cold planer.

The forward movement is provided by the machine.

Operate the equipment with the skid shoes placed on firm and stable on the ground; for safety reasons, keep the front of the prime mover raised a couple inches from the ground.

## 1.3 Attachment Model Numbers

MODEL NUMBER	CUTTING WIDTH
160956	40"
160957	48"

## 2. Safety

### 2.1 General Safety Information



This **SAFETY ALERT SYMBOL** identifies important safety messages on the equipment and in the owner's manual. When you see this symbol, be alert to the possibility of personal injury and carefully read the message that follows.



The signal word **IMPORTANT** identifies procedures which must be followed to avoid damage to the machine.



The signal word **DANGER** on the machine and in the manuals indicates a hazardous situation which, if not avoided, will result in death or serious injury.



The signal word **WARNING** on the machine and in the manuals indicates a potentially hazardous situation which, if not avoided, could result in death or serious injury.



The signal word **CAUTION** on the machine and in the manuals indicates a potentially hazardous situation which, if not avoided, may result in minor or moderate injury. It may also be used to alert against unsafe practices.

**NOTE:** Notes are used to indicate important information. This information may be repeated in other areas of the manual.

### Operating Safety

- Read and follow instructions in this manual and the machine's Operators Manual before operating.
- The manual must always remain with the machine. In case of loss or damage, request a new copy from your dealer or from Blue Diamond®.
- Strictly follow all rules prescribed by the safety pictograms/decals applied to the machine. Ensure that all safety pictograms/decals are legible. If pictograms/decals are worn, they must be replaced with new ones obtained from Blue Diamond® and placed in the position indicated by this manual.
- Before using the machine, make sure that all safety devices are installed and in good working condition. In case of damaged or missing shields, replace them immediately.
- It is absolutely forbidden to remove or alter safety devices and/or safety precautions.
- If the use of the machine is required at night or in conditions of reduced visibility, the work area must be illuminated (200 lux) by use of the prime mover or fixed/immobile auxiliary lighting.



Improper use and maintenance operations can cause serious injury and shorten the useful lifetime of the machines.

The operator and qualified technicians must have thorough knowledge of all requirements listed in this manual before beginning to use the machine or perform maintenance operations.

The procedures contained in this manual shall be understood to apply to the machines only where used for the permitted purposes and with all safety devices and equipment installed and operational; if the machines are used for other purposes or under different safety situations, the customer shall bear direct responsibility for persons involved in accidents or incidents and any unusual wear to the equipments.

## 2. Safety

### 2.1 General Safety Information

#### Cont'd

#### Operating Safety Cont'd

- Pay maximum attention to avoid any accidental contact with rotating parts of the machine.

### 2.2 Operators

#### Qualified Operators

The operator is a person suited to the work and who is physically and psychologically able to withstand the demands connected with operating the equipment for its intended use. The operator must not allow anyone to approach the machine while it is working and must not allow external personnel to operate the machine or attachment.

The operator is to follow the given instructions in this manual and the machine operator's manual in order to obtain maximum performance, minimal fuel consumption, and maximum safety for himself and for others.

The operator is responsible for scrupulously observing all the instructions given in this manual.



**DANGER**



#### **AVOID SERIOUS INJURY OR DEATH**

Operators must receive instructions before operating the machine. Untrained operators can cause serious injury or death.

For an operator to be qualified, he or she must not use drugs or alcoholic drinks which impair alertness or coordination while working. An operator who is taking prescription drugs must get medical advice to determine if he or she can safely operate a machine and the equipment. For an operator to be qualified, he or she must have read and understood the instructions of this manual, he or she must make adequate preparation for the proper use of the machine, and he or she must hold a driving license.

In case of doubt regarding the use of the machine and/or the interpretation of this manual, the operator must contact either their dealer or Blue Diamond®.

#### Operator Training

- Check the rules and regulations at your location. The rules may include an employer's work safety requirements. Regulations may apply to local driving requirements or use of a Slow Moving Vehicle (SMV) emblem. Regulations may identify a hazard such as a utility line.
- The new operator must start in an area without bystanders and use all the controls until he or she can operate the machine safely under all conditions of the work area.

#### Operator Safety

- Before starting, and during operation of the attachment, make sure there are no people or animals in the operation area.
- During operation, adjustment, maintenance, repairing, or transportation of the machine, the operator must always use appropriate Personal Protective Equipment (PPE) including but not limited to safety glasses, working gloves, dust-mask, safety helmet, and hearing protection.
- DO NOT operate the attachment or machine while wearing loose fitting clothing that can be entangled or caught in parts of the machine.
- DO NOT operate the implement when tired, not in good condition, or under the influence of alcohol or drugs.
- Any use of the equipment which does not comply with the uses specified in this use and maintenance manual is strictly prohibited.
- DO NOT stand, move, or work on floors or any non-bearing structures.
- DO NOT use the equipment for planing at levels higher than the prime mover shifting level.
- DO NOT work in dangerous weather conditions (i.e. lightning).
- Make sure the machine being used has all the dead-man's controls fitted and that they are in perfect working order.
- Ensure that normal maintenance has been performed.

## 2. Safety

---

### 2.3 Safety Guidelines

#### Operating Safety

- Read and follow instructions in this manual and the machine's Operator's Manual before operating.
- Check that the attachment has not suffered any damage during transportation. If so, immediately contact Blue Diamond® Product Support.
- Under NO circumstances should young children be allowed to work with this equipment.
- This equipment is dangerous to persons unfamiliar with its operation.
- Check for overhead and/or underground lines before operating equipment (if applicable).
- In addition to the design and configuration of equipment, hazard control and accident prevention are dependent upon the awareness, concern, prudence and proper training of personnel involved in the operation, transport, maintenance, and storage of equipment.
- Check that the attachment is securely fastened to the machine.
- Make sure all the machine controls are in the NEUTRAL before starting the machine.
- Operate the equipment only from the operator's position.
- Operate the equipment according to the Operator's Manual.
- When learning to operate the equipment, do it at a slow rate in an area clear of bystanders.
- DO NOT permit personnel to be in the work area when operating the equipment.
- The attachment must be used ONLY on approved machines.
- DO NOT modify the equipment in any way. Unauthorized modification may impair the function and/or safety and could affect the life of the equipment.
- No modifications may be made to the equipment or its components without written authorization from Blue Diamond®. Unauthorized modifications may alter the design parameters for the original performance of the equipment, resulting in the termination of any and all warranties as well as civil and/or criminal responsibility for damage or injuries.
- DO NOT make any adjustments or repairs on the equipment while the machine is running.
- Keep shields and guards in place. Replace if damaged.
- DO NOT operate equipment in poor visibility conditions such as fog, darkness, or any conditions that limit clear visibility less than 33 feet (10 m) in front of and to the sides of the equipment.
- When conditions make it necessary to slow ground speed, shift to a lower gear rather than reducing engine speed. The engine will maintain rated speed and keep the cold planer running at optimum milling speed.
- DO NOT operate in a work area that has not been inspected for foreign debris and obstacles.
- Remove any foreign objects and clearly mark any objects that cannot be removed.
- Wear safety glasses, gloves, hearing protection, and other protective clothing when required.
- Only use spare parts supplied by Blue Diamond®, as they offer functional and durability as well as easy interchangeability.
- Any repairs needed must be carried out solely by authorized personnel, using original spare parts. If this rule is not applied, the user could be exposed to serious risks.
- The prime mover must NEVER be moved sideways when the drum is in use.
- DO NOT leave the equipment installed on the machine unattended in the work area.

## 2. Safety

---

### 2.3 Safety Guidelines Cont'd

#### Machine Requirements and Capabilities

- The machine's operator's cab should be equipped with a thermoplastic polycarbonate or similar material front window, and similar protection on the sides of the operator's cab before operating the equipment.
- Keep bystanders clear of moving parts and the work area. Keep children away.
- Use caution on slopes and near banks and ditches to prevent overturn.

#### Residual Risks

- When the equipment is in use, the following risks may arise:
  - Electric shocks from contact with underground power lines.
  - Fire and explosions through contact with underground gas lines.
- Anyone standing in the vicinity of the equipment may be exposed to the following risks:
  - Risks originating from blows, catching, or shearing as result of accidental contact with the rotating drum
  - Risk of crushing between the equipment and the prime mover.
  - Risk of rubble (stones, blunt objects, etc.) being thrown out.
  - Risk of falling spoil (when working on uneven ground or on surfaces at different heights).

#### Environmental Conditions

- With working temperatures below 14°F (-10°C), let the skid steer loader idle before beginning work, and when the hydraulic circuit exceeds 32°F (0°C), run the machine until the working temperature has been reached.
- The work area must comply with the regulations in force concerning hygiene and safety in the workplace.

- If the equipment is required to be partially immersed in saline environments, contact Blue Diamond® Product Support.
- No naked flames and such near the equipment.
- DO NOT use the equipment in environments where there is a risk of explosion or fire.

#### Fire Prevention Safety

- Flammable debris (leaves, grass, etc.) must be removed regularly. If flammable debris is allowed to accumulate, it can cause a fire hazard. Clean often to avoid this accumulation.
- The equipment's hydraulic motor compartment must be inspected every day and cleaned if necessary to prevent fire hazards and overheating.
- All fuels, most lubricants, and some coolant mixtures are flammable. Flammable fluids that are leaking or spilled onto hot surfaces or onto electrical components can cause a fire.

#### Transporting Safety

- Comply with federal, state, and local laws governing highway safety and movement of machinery on public roads.
- Check local laws for all highway lighting and marking requirements.
- Always yield to oncoming traffic, and move to the side of the road so any following traffic may pass.
- Never allow riders on either machine or equipment.
- If transporting the equipment on a truck or trailer, make sure the equipment is properly secured to the transport vehicle.
- Machines with attachments installed have a different center of gravity and overall dimensions.

## 2. Safety

### 2.3 Safety Guidelines Cont'd

#### Transporting Safety Cont'd

- The operator must take great care during movements and maneuvers, avoiding dangerous imbalances and proceeding at low speeds at all times. Keep the attachment raised a few centimeters from the ground.
- It is mandatory to remove the attachment from the prime mover when driving on public roads unless the prime mover's vehicle registration and road-worthiness approval have been updated specifically.
- Blue Diamond® shall not be held responsible for either criminal or civil consequences deriving from failure to obey or abuse of these requirements and limitations.
- Check the position of the light clusters, modifying it where necessary depending on the equipment installation. All applicable legislation must be followed for any modifications.

#### Hydraulic System

- Ensure that the hoses are sufficient to resist the auxiliary pressure of the prime mover and that the hoses and connectors are correctly connected.
- All inspections of the hoses and fittings must be carried out using suitable personal protective equipment (PPE).
- Check hydraulic tubes, hoses, and fittings for damage and leakage. Never use open flame or bare skin to check for leaks. Hydraulic tubes and hoses must be properly routed and have adequate support and secure clamps. Tighten or replace any parts that show leakage.
- Always clean fluid spills. **DO NOT** use gasoline or diesel fuel for cleaning parts. Use commercial nonflammable solvents.

#### Safety Devices

- The safety tools must **NEVER** be tampered with.
- The equipment must **NEVER** be used without the safety guards fitted.
- Always use the appropriate personal protective equipment (PPE) when performing any type of maintenance.
- The tools can reach high temperatures during work; it is therefore necessary to wait for them to cool and use appropriate gloves if it is likely to come into contact with them.

#### Personal Protective Equipment



**Proper Work Clothes:** To help ensure your safety as a designated operator wear proper work clothes including tight fitting clothes, protective gloves and shoes.



**Hand Protection:** To help ensure your safety as a designated operator wear protective gloves.



**Protective Shoes:** To help ensure your safety as a designated operator wear protective shoes.



**Safety Helmet:** To help ensure your safety as a designated operator wear a safety helmet.



**Safety Helmet and Eye/Ear Protection:** To help ensure your safety as a designated operator wear a safety helmet and eye/ear protection.



## 3. Transport

### 3.1 Delivering & Unloading

The Extreme Duty Series 2 Cold Planer is normally transported and delivered securely, fastened to a pallet in a stable position and duly wrapped in plastic sheeting. The type of packing may vary according to the desired means of transport and destination.

#### **IMPORTANT**

- Any optional materials (spare teeth, adapter plate, connecting hoses, keys for teeth replacement, etc.) are contained in a separate package.
- Upon receiving the attachment, check it for any damage (major breakages or dents) caused during transportation. If any are found, the carrier must be alerted immediately and the statement “Accepted Conditionally” must be added to the delivery note.
- In the event of damage, give notice of the fact to the carrier in writing within eight (8) days of the receipt of the equipment.
- If, upon delivery, major damage caused during transportation is noted or any parts that should be included are found to be missing, Blue Diamond® Product Support must be promptly notified of the situation.
- It is also essential to check the equipment delivered against the information given in the itemized shipping document.

#### **WARNING**

- The packed unit must be unloaded with the utmost care using lifting equipment with a suitable capacity (e.g. fork lift or other appropriate means).
- The entire unit must be placed on a flat, stable surface.
- All load handling operations must be carried out by qualified personnel in compliance with regulations in force concerning safety in the workplace.
- Dispose of the packing in compliance with the regulations in force in the country of use.

### 3.2 Handling, Transportation, & Lifting



#### **WARNING**



- If the approval of the skid steer/prime mover to travel on normal roads does not extend to the attachment, it must be removed before transportation on open roads.
- Only small movements may be performed on the worksite when the attachment is mounted on the prime mover; during these movements, shifting must be carried out at low speeds with the attachment close to the ground with the prime mover arms. All personnel, bystanders, etc. must be kept at a safe distance away.
- The attachment must always be removed from the prime mover before the vehicle is driven up loading ramps.
- The attachment must NOT be operated during handling.

#### **Handling Over Short Stretches (In the Workplace)**

- Use the skid steer, leaving the cold planer attached.
- Secure the equipment to the pallet, and handle it with a forklift or a transpallet.

#### **Handling Over Long Stretches**

- Secure the equipment to a pallet, using a forklift or a transpallet for handling, then load it onto the method of transportation.

## 3. Transport

### 3.2 Handling, Transportation, & Lifting Cont'd

#### Lifting from One Surface to Another (e.g. to Load onto a Truck)

- Use a lifting crane or truck with a suitable capacity for the weight specified on the serial plate. Connect the cables or chains at the two (2) points shown with the relative stickers. When lifting, use hooks or straps capable holding the cold planer's weight.



#### WARNING



- Check that the capabilities of the cables, chains, and lifting and transportation method in general are compatible with the attachment weight specified on the serial plate.
- Keep the attachment close to ground (safe height of 1.5 ft. or 0.5 m) when moving with it attached to the skid steer.
- Shifting is only permitted on flat or slightly loose ground as long as stability is never jeopardized.
- Check that the pallet on which it will be stored is in suitable condition.

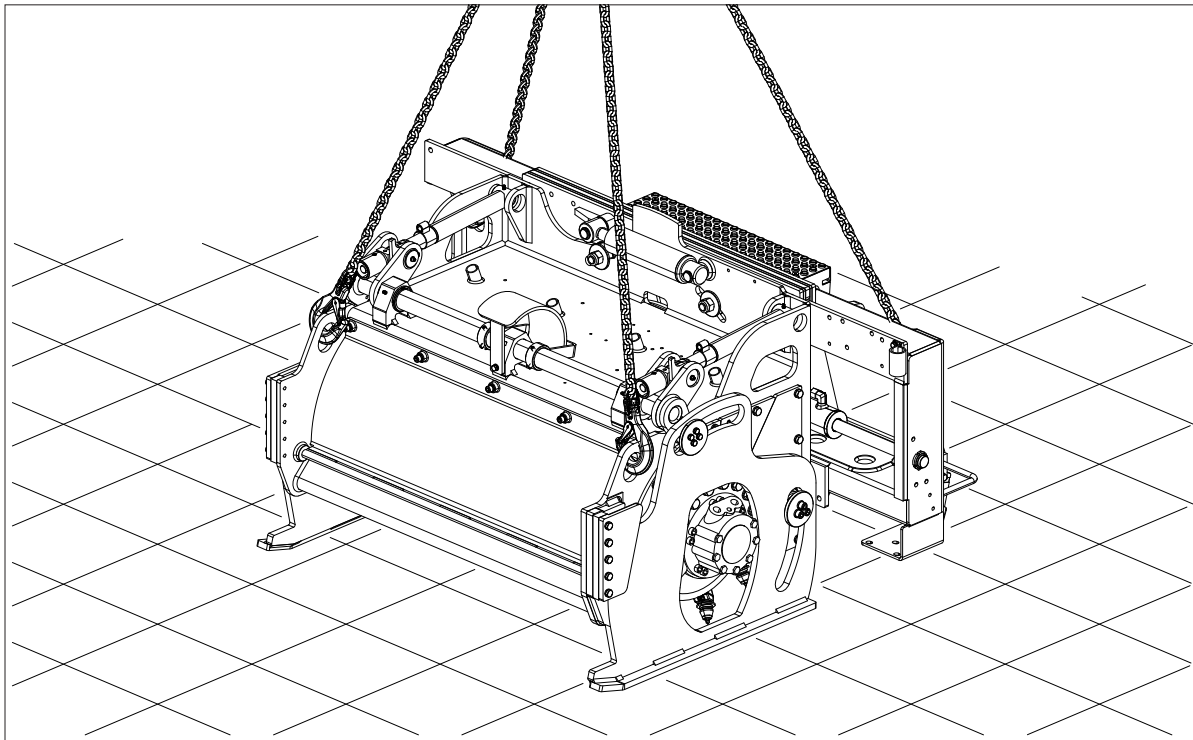

Figure 1

## 4. Use



### WARNING



- The operator is responsible for checking that the machine meets the attachment specifications.
- The attachment may only be fitted onto machines that are equipped with safety systems that disable the machine's controls when there is no one in the operator's position.



### WARNING



- Before starting, the operator must perform some simulated maneuvers to gain confidence with the equipment. This must be performed in a restricted area where bystanders are kept clear. The operator must practice until he or she is confident under any working condition.
- Be careful when passing near open excavations, slopes, and verges.

### 4.1 Preliminary Checks

Before proceeding with the connection to the attachment, the machine being used must undergo checks:

1. Check that all safety and braking devices (parking brakes) are in working order.
2. Check that all the quick couplings (when featured) on the machine, attachment, and other components related to the coupling system are in good condition.



### WARNING



Machines with the attachment installed have a shifted center of gravity, weight, etc. and take up more space than the machine by itself. Be careful when moving, and proceed at a low speed, avoiding any sudden movement that can result in significant and dangerous variations in the machine stability or balance.

### 4.2 How to Enter & Exit the Skid Steer



### WARNING



- Always ensure that there are three (3) points of contact (grip or support) when getting in and out of the machine to ensure balance is maintained in order to not fall.
- The foot CANNOT be resting on the surface of the structure marked with the "Rotating Drum" safety decal.

#### How to Enter

1. Rest the left foot on the lower step [Figure 2, Item 1] of the attachment.
2. Shift the weight on the left foot, and then raise the right foot onto the upper step [Item 2] of the equipment.
3. Put the weight on your right foot, then raise your left foot onto anti-slip step [Item 3] of the prime mover.

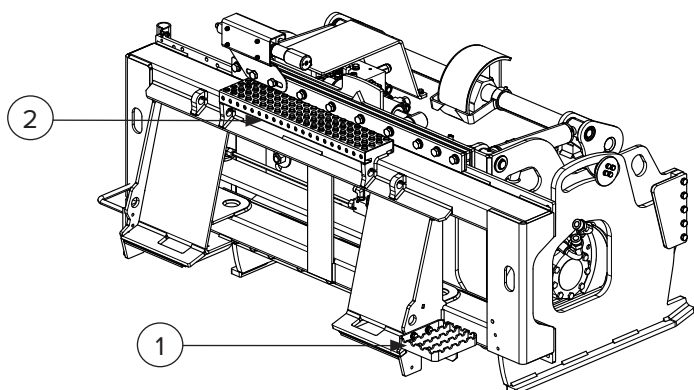

Figure 2

## 4. Use

### 4.2 How to Enter & Exit the Skid Steer Cont'd

#### How to Exit

Reverse the steps of “How to Enter”.

If the lower step is installed on the equipment’s left side, get on and off the equipment as instructed above with the foot motion in reverse.



#### WARNING



- Always use the anti-slip steps to get in and out of the skid steer.
- Never get in or out from the front part of the attachment. The operator must ensure their shoes are free of mud or any other material which could cause them to slip.

### 4.3 Machine/Prime Mover Coupling

The attachment must be mounted on the skid steer’s arm in place of the bucket. Apart from the general instructions given below, the procedures outlined in the machine’s manual (see specific section on the application of the attachment) must also be followed.

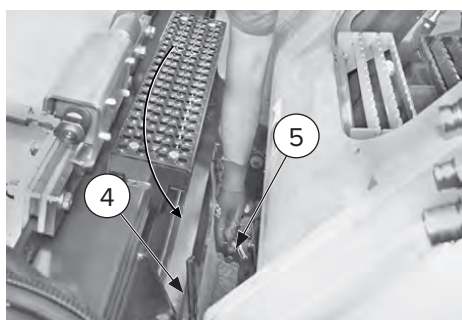
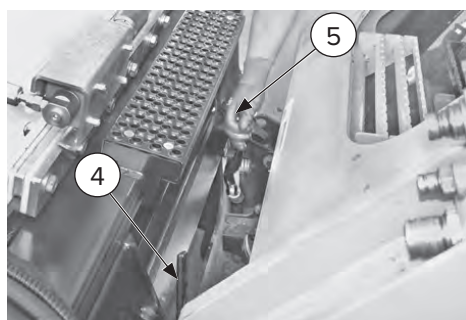
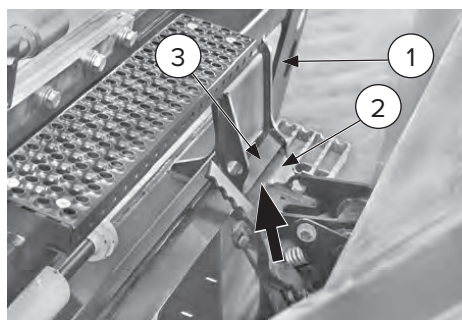
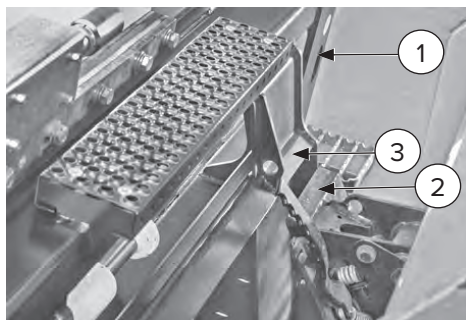

Figure 3

The outlined instructions below must be carried out for a universal skid steer mount.

1. Position the attachment [Figure 3, Item 1] in the non-operative position and with its skid shoes on flat, compact ground and away from ditches, fuel stores, electrical substations, or any other hazard risk.
2. Slowly bring the arm of the machine towards the attachment in order to position the attachment plate [Item 2] below the upper lip [Item 3] of the attachment mount.
3. Operate the machine hydraulic controls in order to bring the mount plate towards the attachment [Item 2] until it is completely resting on the attachment mount.
4. Turn off the engine of the machine, and remove the key from the ignition. Exit out of the machine and push the two levers [Items 4 and 5] to engage the quick coupling lock pins. Check that the levers are locked in the retaining position and that the pins are inserted in the holes of the attachment mount.



#### CAUTION



When the operations above are completed as described above and the pins inserted are checked, lift the equipment off the ground.

## 4. Use

### 4.4 Machine/Prime Mover Hydraulic Connection



#### CAUTION



- The machine is connected to the prime mover via hydraulic hoses. Make sure the hoses are not tangled together and are not likely to be crushed or exposed to tension during work maneuvers, as this could prove hazardous.
- Residual risk of burns: the hydraulic oil and hoses can reach extremely high temperatures; use appropriate personal protection equipment (PPE).
- The operation must be carried out by one (1) person (the operator) only.

To connect the hoses, proceed as follows:

1. Release the pressure in the hydraulic system (see prime mover instructions).
2. Connect the case drain [Figure 4, Item 2] first, and then connect the supply and return lines [Item 1]. (See “4.5 Connecting Flat-Faced Quick Couplings” on page 16.)
3. Connect the 8-way valve hoses [Item 2] using the quick couplings.

4. Connect the electrical cable [Item 3] to the prime mover arm socket [Item 4].
5. Check for oil leaks.
  - Enter the machine, and start the engine.
  - Engage the high-flow auxiliary machine control to power the hydraulic motor.
  - Engage the standard auxiliary machine control from the machine to the supply power to the other machine functions.
  - Switch off the engine, remove the ignition key, and exit the prime mover. Check for any signs of leaks around the hose couplings.



#### IMPORTANT



- When connecting the hoses to the prime mover, the drain line featured must be connected first.
- If screw quick couplings are used, check closely that they have been completely and correctly screwed on.

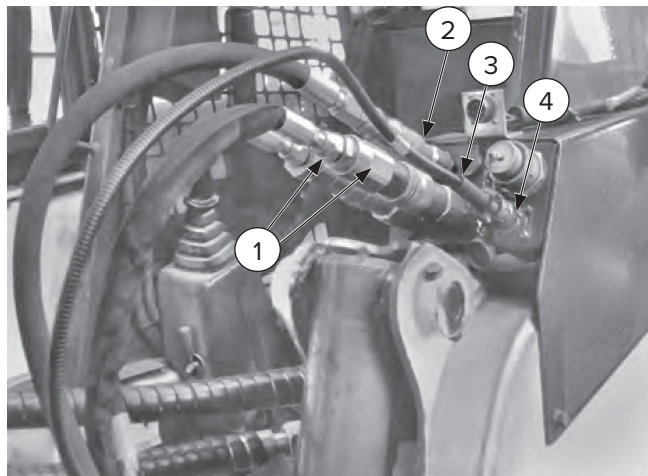

Figure 4



## 4. Use

### 4.5 Connecting Flat-Faced Quick Couplings

To connect the flat-faced couplings, proceed as follows:

1. Push the male section [Figure 5, Item 1] into the female section [Item 2] until it clicks into place in the ring nut [Item 3].
2. Turn the ring nut [Item 3] so that the notch [Item 4] is not aligned with the spherule [Item 5], thereby preventing accidental disconnection.

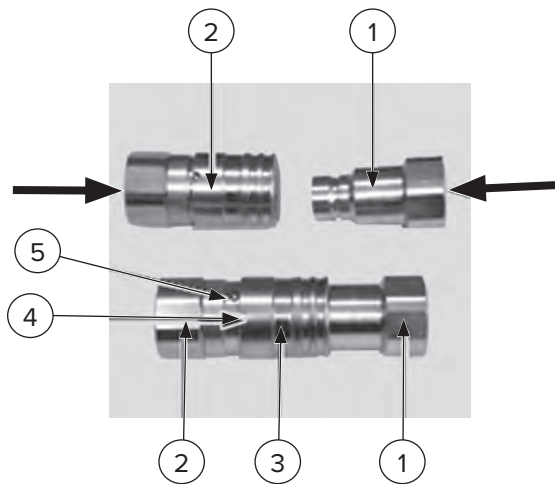

Figure 5

**NOTE:** Figure 5 shows flat-faced quick couplings with a snap-fastening safety ring nut.



### WARNING



- Before connecting together, carefully clean all the quick couplings on the attachment and the prime mover.
- If, for some reason, there is residual pressure in the prime mover's hydraulic system, the male section of the coupling will not be able to fit into the female section. Follow the instructions given by the prime mover's manufacturer to relieve the pressure.

### 4.6 Machine/Prime Mover Connections Disengage



### CAUTION



- Before leaving the operator's seat on the machine, make sure the attachment is resting on flat, level ground, the key is removed from the ignition, and the machine is stabilized with the parking brake engaged.
- Residual risk of burns: the hydraulic oil and hoses can reach extremely high temperature; use appropriate personal protection equipment (PPE).



### IMPORTANT



Always disconnect the drain line last.

To disconnect the hoses, proceed as follows:

1. Stop the engine.
2. Discharge the residual pressure in the system.
3. Exit the prime mover, and disconnect the quick coupling fittings.
4. To disconnect the hoses with the flat-faced quick couplings: turn the ring nut [Figure 6, Item 3], so that the notch [Item 4] lines up with the spherule [Item 5], push the ring nut [Item 3] towards the spherule [Item 5] to disconnect the quick coupling.



## 4. Use

### 4.7 Machine/Prime Mover Disconnect



Ensure that the hydraulic connections have already been disconnected (see “4.6 Machine/Prime Mover Connections Disengage” on page 16).

How to connect a universal skid steer mount:

1. Position the equipment on firm, level ground and away from ditches, fuel stores, electrical substations, or any other hazard risk.
2. Stop the engine, stabilize the prime mover (i.e. with the parking brake, wheel chocks, etc.), and relieve the hydraulic pressure.
3. Remove the ignition key, exit the prime mover, and disconnect the hydraulic lines and the electrical cable (see “4.4 Machine/Prime Mover Hydraulic Connection” on page 15).
4. Pull the two (2) levers [Figure 6, Item 1] towards you to release the quick coupling locking pins.
5. Enter the prime mover, and start the engine. Operate the commands to tilt the attachment plate [Item 2] and at the same time, lower the arm [Item 3] until the attachment plate disengages from the upper lips [Item 4] of the attachment.
6. Slowly reverse the prime mover away from the attachment.

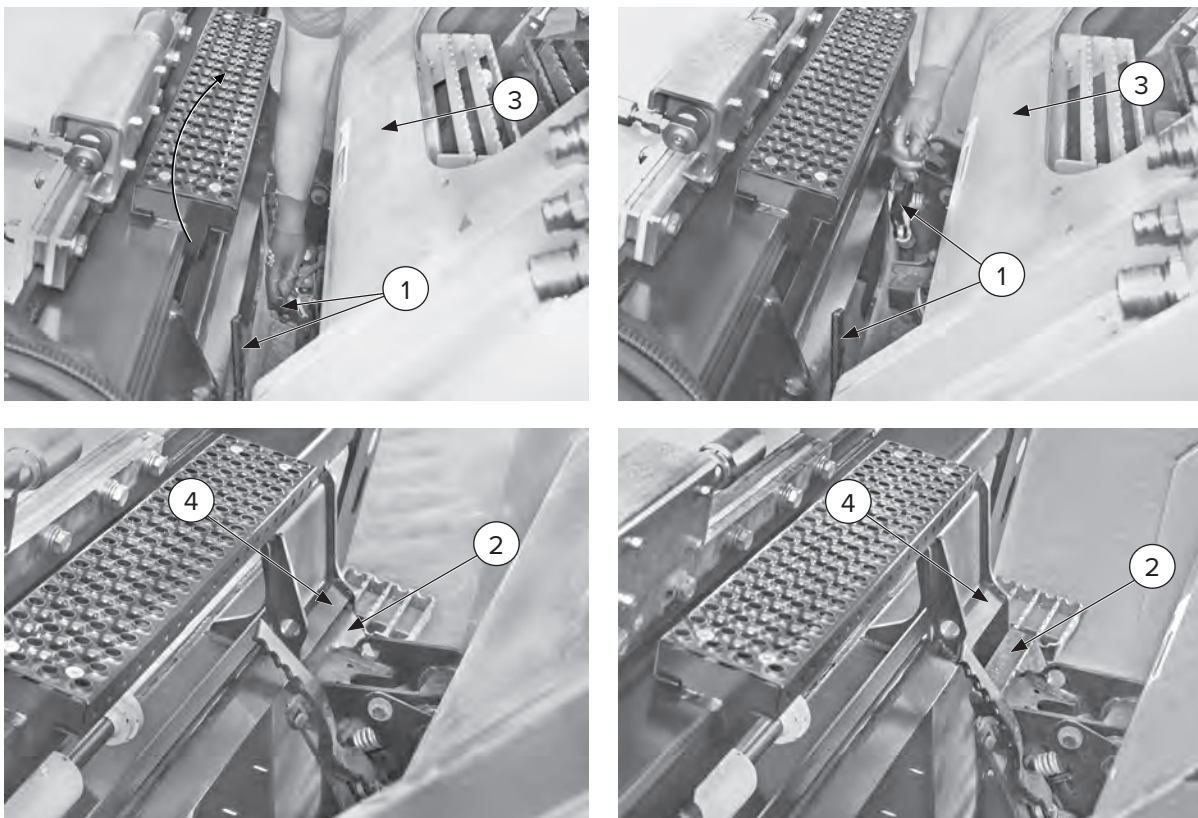

Figure 6

## 4. Use

### 4.8 Starting Up



#### CAUTION



- The operation must be carried out by one (1) operator only. Check that nobody is within the prime mover's range or within a minimum range of 30 ft (10 m). Cordon off the work area.
- The operator must NOT drive the machine when under the influence of alcohol or drugs, which may impair physical or mental faculties.
- The operator must NOT leave the prime mover unattended without first engaging the safety locks and removing the ignition keys.
- Always work at a safe distance from open excavations and/or slopes and drop-offs.
- Before getting started, make sure there are no buried pipelines which could interfere with excavation work (gas, water, electricity, etc.).
- During work, keep a close eye out for any oil leaks.
- Check that there are no obstructions or hindrances on the work surface.
- On finishing the work, stop the machine before moving it away from the work surface. Always stop the attachment when the prime mover is in transit.



#### WARNING



- The equipment described in this manual is compatible with prime movers with 3 or 5 hydraulic lines to enable any additional equipment.
- If the prime mover is NOT equipped to electrically activate the equipment functions, Blue Diamond® will supply a control panel to be installed in the cabin.

The following checks must always be performed prior to starting the equipment:

- Check that there are no leaks in the hydraulic circuit.
- Check that mechanical and electrical connections have been made correctly.
- Check that the work area is free of people and materials.



#### IMPORTANT



Whenever the equipment has been left still or disconnected, start it up slowly with the prime mover engine idling; then accelerate slowly and gradually.

The equipment can only be activated (i.e. drum start rotating) using the controls on the prime mover.

1. Turn on the prime mover's engine, switch on the hydraulic system and wait for the oil to reach optimum temperature and for any air bubbles in the system to be expelled.
2. Activate the machine High-Flow auxiliary control to start the oil flow and the drum.

**NOTE:** For information on how to activate the hydraulic system, see the prime mover manual or the user instructions.

### 4.9 Preparing the Equipment for Use

**NOTE:** All these settings must be adjusted with the drum stopped and, if required, with the prime mover motor idle.

Before milling, the operator must prepare the equipment to perform the functions required by excavation or by the surface scarification works. Therefore, he or she must decide the following:

1. Whether to move the cutting unit when milling near walls, curbs, or sidewalks (e.g. beyond the external edge of the prime mover).
2. Milling depth.

## 4. Use

### 4.10 Cutting Unit Sideshift Function

It must be performed with the cutting unit in stop and raised an inch from the ground, and the prime mover motor idle.

Start the prime mover controls or the control panel to activate this function.

### 4.11 Floating Tilt Function

The equipment can be supplied as standard with a mechanical device that allows tilting the cutter body [Figure 7, Item 1] with respect to the mount [Item 2].

During planing works, if the prime mover comes across a hindrance (e.g. a manhole) or if one side is working on the section already planed, the mount [Item 2] follows the movements of the prime machine to which it is fastened, while the drum [Item 1] is in constant contact with the surface being worked.

Thanks to a pivot (between the drum and the mount) and to the spring jack [Item 3], the mount [Item 2] and the drum [Item 1] can rotate with respect to one another, to prevent damages to the equipment structures and keep the drum [Item 1] in constant contact with the surface being worked.

A graduated scale, the tilt indicator [Item 4] on the equipment allows the operator to see the tilting angle at which the equipment is working right from the working stations.

The maximum tilt value is eight (8) degrees to the left and eight (8) to the right; this value is ensured by the slots [Item 5] that also limit the rotation.

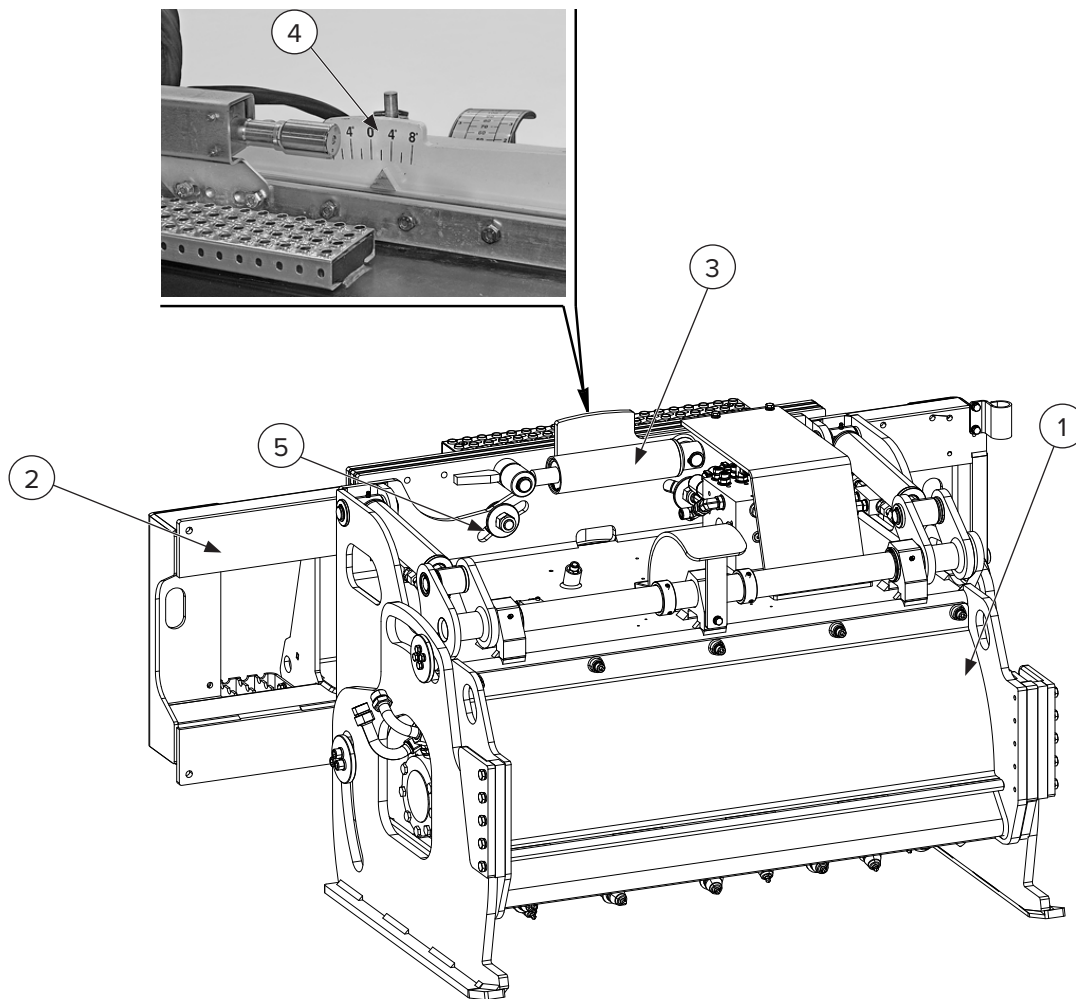

Figure 7

## 4. Use

### 4.12 Planing Depth

#### Adjusting the Planing Depth

**NOTE:** The planing depth is expressed both in millimeters and in inches.

**NOTE:** For a perfect depth adjustment, make sure that the depth indicators have been reset first (see next section).

1. Lift the equipment approximately 20 in. (50 cm) off the ground.
2. Use the prime mover or control panel controls to adjust the planing depth.
3. Use the graduated index [Figure 8, Item 1] and the reference rod [Item 2] to define the depth reached.

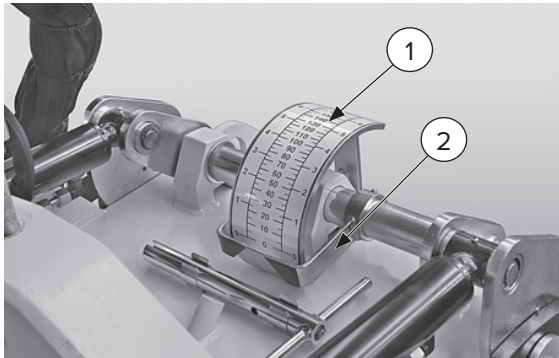

Figure 8

#### Planing Depth Adjustment Reset

If an accurate planing depth must be ensured, certain factors, such as teeth or skid shoes wear, may affect the “zero” position indicated on the indexes.

For this reason, check that the indexes are correctly reset with respect to the graduated scales.

Perform the following operations:

1. Set the minimum planing depth.
2. Rest the skid shoes on a flat and compact ground.
3. Lower the drum by adjusting the depth on both sides until it skims the ground.
4. Open the inspection cover and manually turn the drum to check that all the teeth are skimming the ground and are parallel to it.

5. Loosen the nuts [Figure 9, Item 1] on both depth cylinders.
6. Set both depth cylinders [Item 2] to “0” on the measuring scale [Item 3].
7. Tighten the nuts [Item 1] and set the desired planing depth.

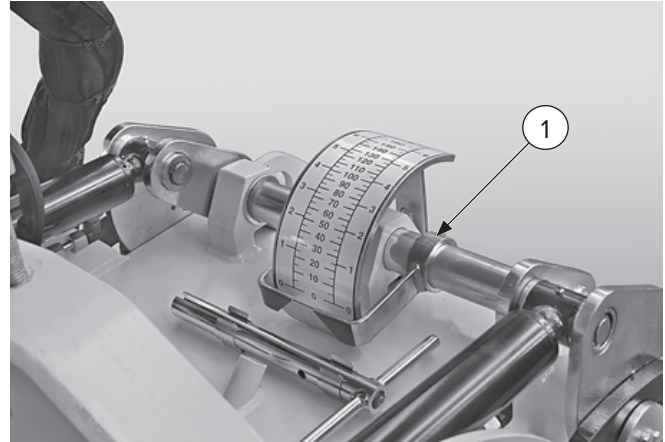

Figure 9

**NOTE:** This adjustment allows the reset to be performed; however it may also make it difficult to reach the maximum depth, due to the hydraulic cylinders limit switch.



## 4. Use

### 4.13 Work Start Procedure



#### CAUTION



If no water is sprayed to reduce dust while working, a dust mask or respirator must be worn.

**NOTE:** Before starting to dig, check that the provisions set forth in “4.9 Preparing the Equipment for Use” on page 18 as been observed.

1. Move the equipment to the start of the working site, keeping the unit [Figure 10, Item 1] at the center of the mount so that the entire structure is so balanced.
2. Tilt the equipment forward, resting on the front of the skid shoes [Item 2]. Force the prime mover arm to lift the front tracks or wheels a few centimeters from the ground.

3. Start the drum turning slowly, keeping the prime mover engine idling, then accelerate gradually until the maximum engine speed is reached.
4. Using the prime mover controls or the control panel supplied, raise the left and right skid shoes alternatively by three-quarters of an inch (20 mm) at a time until the desired planing depth which can be checked on the graduated scale.



#### IMPORTANT



- During the entire procedure to reach the milling depth, make sure that the front tracks or wheels are still raised from the ground.
- The prime mover front tracks or wheels must remain raised during the entire milling operations.

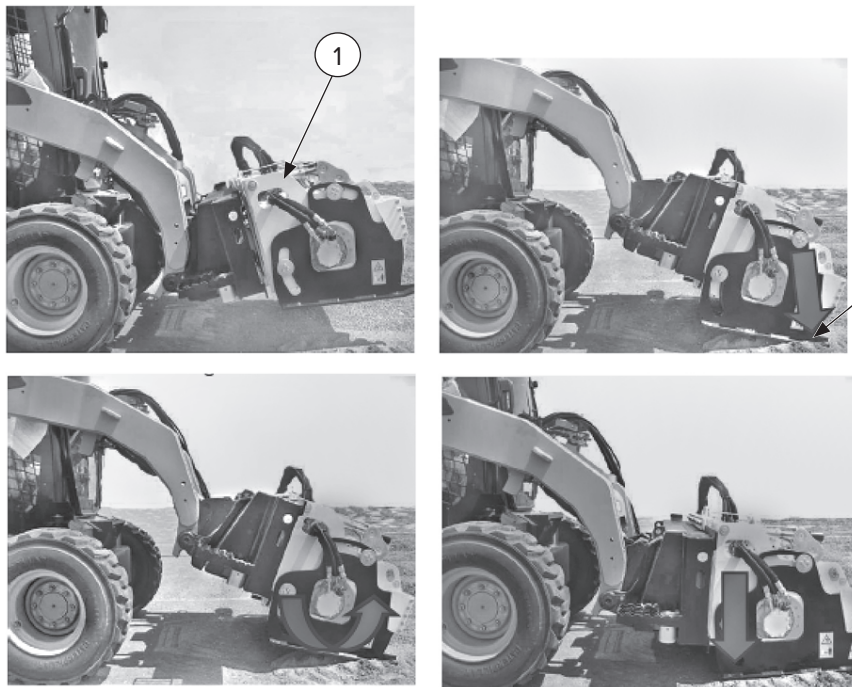

Figure 10

## 4. Use

### 4.13 Work Start Procedure Cont'd

#### If the Drum Stops Due to Foreign Objects

1. Keep the prime mover arm slightly raised, retract the support plate, and rest the equipment on the ground against the back of the support slides, so that the drum can still rotate.
2. Stop the engine, secure the prime mover by engaging the parking brake, and exit.
3. Remove the key from the ignition.
4. Remove the screws [Figure 11, Item 1] and open the protection guard [Item 2].
5. Wearing suitable personal protection equipment (PPE), inspect the drum [Item 3], and try to remove the cause of the blockage.

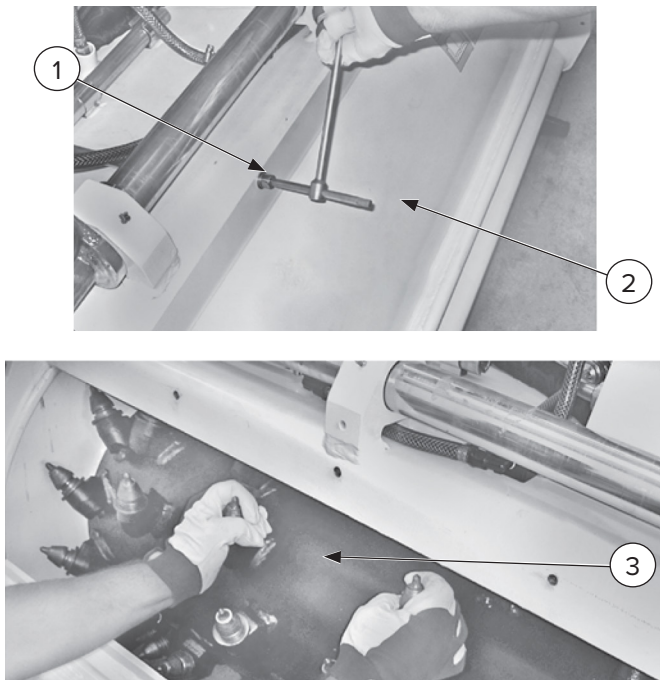

Figure 11

### 4.14 Planing in Parallel Passes

If the desired planing width is greater than the width of the cutting drum supplied, side-by-side planing can be performed.

1. Dig the first trench as described in 4.13 Work Start Procedure and, if possible, clean the trench from any debris, to improve its quality and avoid creating steps between one pass and the next.
2. Bring the prime mover at the beginning of the trench, and align with it, so that the drum is placed in line with the trench edge.
3. If debris has been removed from the previous trench, adjust the skid shoe which will rest on the planed bottom at "0 mm" of height, while the side board resting on the bottom to be planed must remain at the previously set planing depth.



Figure 12

4. The floating tilt function will allow the prime mover to follow the ground's coarseness, and in particular, if required, adapt the tilting with respect to the planer when its wheels go over the already-planed section.
5. Start planing according to the description in 4.13 Work Start Procedure.



## 4. Use

### 4.14 Planing in Parallel Passes Cont'd



Figure 13

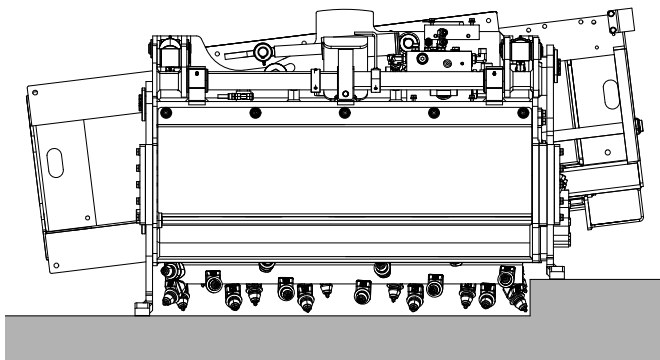

Figure 14

### 4.15 Water Spraying Unit (Optional)

#### **! IMPORTANT !**

- Only fill the unit with water that is free from impurities.
- If the tank is installed on the roof of the prime mover, DO NOT start the electric pump when the equipment is disconnected from the prime mover to avoid damaging it.

Blue Diamond® will supply a control panel with a switch that activates the water spraying pump.

The water container is installed on top of the prime mover.

### 4.16 Removable Right Skid Shoe (Optional)

Removing the right skid shoe reduces the distance between the right edge and the drum to a minimum when working alongside walls, sidewalks, etc.

The right skid shoes can be removed or installed based on the work to be performed.

### 4.17 Stopping the Equipment in Normal Conditions

In normal conditions, the prime mover controls must be used to stop the machine (by slowing the diesel engine down to idling speed, then cutting off the hydraulic oil flow). This way, the machine will stop immediately.

### 4.18 Emergency Stops

To stop the machine in an emergency, the operator must use the appropriate controls on the prime mover and stop the diesel engine with the ignition key.



**WARNING**



For further details on how to stop the machine, refer to the prime mover's instruction manual.

## 4. Use

### 4.19 Parking

Rest the equipment to the ground, stop the prime mover's engine, engage the brake or other parking devices, and remove the ignition key.



#### WARNING



- Every time a working cycle ends, bring the milling depth to “0” by lowering the skid shoes all the way and making sure that the equipment is resting on the ground.
- Park the vehicle in a suitable place where there are no risks of the equipment being damaged.
- If the operator leaves the equipment unattended, the keys must be removed from the prime mover and measures must be taken to ensure no unauthorized persons can enter and use it.

### 4.20 Preparing the Unit for Long Periods of Inactivity

If the equipment is not to be used for some time, it must be stored in a sheltered area where it cannot get knocked or hit.

Position the equipment on a pallet (making sure it is stable), then proceed as follows:

1. Wash it carefully.
2. Check for and fix any oil leaks.
3. Check for and replace any damaged parts.
4. Remove the tools, and apply a water-based asphalt emulsifier (ex. Zep's #AR6690) or dish soap (ex. Dawn dish soap) to them.
5. Apply a water-based asphalt emulsifier (ex. Zep's #AR6690) or dish soap (ex. Dawn dish soap) to the tooth holder.
6. Lubricate the depth and movement adjustment piston exposed parts.
7. Place a sheet over the equipment to protect it from dust.

8. Cordon off the area where the equipment is located to prevent anyone accidentally knocking against its corners, sharp edges, or blunt parts.

### 4.21 Recommissioning the Unit after Long Periods of Inactivity

Before starting up the equipment again after a long period of disuse, the following checks must be carried out:

1. Grease all the pivot points.
2. Check for and fix any oil leaks.
3. Check the condition of the hoses.
4. Check that there are loose, worn out, or missing parts.
5. Check all hardware for proper torque.

### 4.22 Disposal

When disposing of the equipment or its parts (oil, hoses, plastic parts, etc.), always comply with the local, state, and federal laws.

## 5. Maintenance

### 5.1 Service Schedule

DESCRIPTION	SERVICE PROCEDURES					
	Check	Clean	Lube	Change	Adjust	Drain
<b>Hourly Maintenance</b>						
Drum	•					
Teeth	•					
<b>8 Hour Maintenance</b>						
Water Kit Nozzles	•					
<b>50 Hour Maintenance</b>						
Lubrication			•			
Hoses	•					
Equipment		•				
<b>100 Hour Maintenance</b>						
Frame (cracks, bends, or damage)	•					
All Hardware	•				•	
<b>200 Hour Maintenance</b>						
Drain Line Safety Cover	•					
<b>When Required</b>						
Side Slides				•		
Teeth				•		

**NOTE:** Contact Blue Diamond® Product Support with any questions.

## 5. Maintenance



### WARNING



- All maintenance work must be carried out with the equipment detached from the prime mover and positioned on the ground.
- Maintenance operations must be carried out in a suitable place, in compliance with the safety regulations in force.
- Clean all parts of the equipment thoroughly before beginning any maintenance work on it (see “Equipment Cleaning” on page 29 under 5.4 Every 50 Hours).
- Appropriate personal protective equipment (PPE) must be used throughout maintenance.

### 5.2 Every Hour

#### Inspection of the Drum

There are two (2) checks to be performed on the drum: the teeth conditions and any damage or lack of teeth holder.



### WARNING



- Never work with damaged and/or missing teeth and teeth holder.
- Before leaving the operator’s seat on the prime mover, make sure the area is flat, the prime mover is stabilized, the equipment is resting on the ground, and the keys have been removed from the ignition.

The drum is the most important element of the equipment.

Because of the type of work it does, it is easily damaged.

Visually check the drum after it hits any solid object, such as hatches, iron obstacles, manholes, etc.

**NOTE:** Just like the tools, the drum is subjected to wear, and therefore excluded from the warranty.

**NOTE:** If the drum is very damaged (missing or broken tooth holders, etc.), contact Blue Diamond® Product Support.

To inspect the drum, rest the equipment on the ground in the parking position, after adjusting milling depth to a minimum. Then perform the following operations:

1. Keeping the prime mover boom lowered, retract the support plate and rest the equipment on the ground by keeping the drum slightly raised.
2. Remove the screws [Figure 15, Item 1], and open the guard [Item 2].
3. Grip the tools to make the drum [Item 3] turn in the work direction, and inspect it.

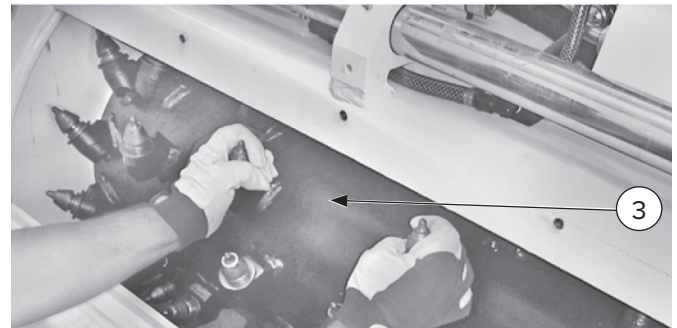
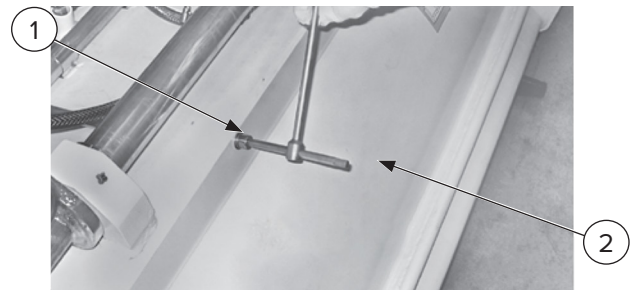

Figure 15

#### Tool Integrity Assessment (Teeth)



### WARNING



- Never work with damaged or missing teeth.
- Before leaving the operator’s position on the prime mover, make sure the area is flat, the prime mover is stabilized, the equipment is resting on the ground, and the keys have been removed from the ignition.

Every tooth is subject to constant wear due to contact with the material cut. The greater the wear, the less the tooth’s capacity for breaking into the material.

## 5. Maintenance

### 5.2 Every Hour Cont'd

#### Tool Integrity Assessment (Teeth) Cont'd

As tooth wear increases, the work progress slows. This means that if very worn teeth are used, the equipment's productivity drops noticeably.

Replacing the teeth promptly will ensure the equipment is always working at full performance.

It is always worthwhile checking for signs of wear as the tooth only really performs well throughout its working life if it is worn down evenly.

To check the drum and replace the teeth if required, remove the screws [Figure 16, Item 1] and tilt the guard [Item 2] outward.

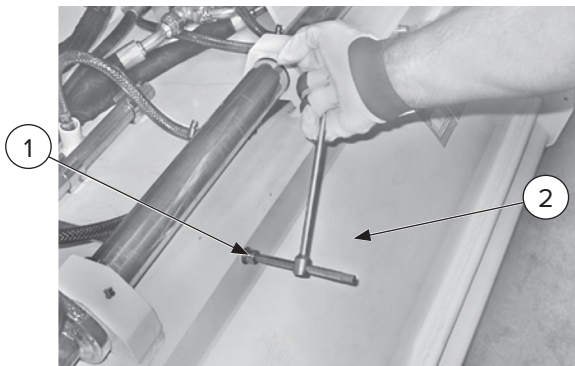

Figure 16

#### Tooth Wear

Figure 17 shows features of an ideally worn tooth that needs replaced.

The remaining part of the carbide tip is symmetrically shaped, the body has a uniform, tapered shape, the body has enough bulk to support the carbide core.

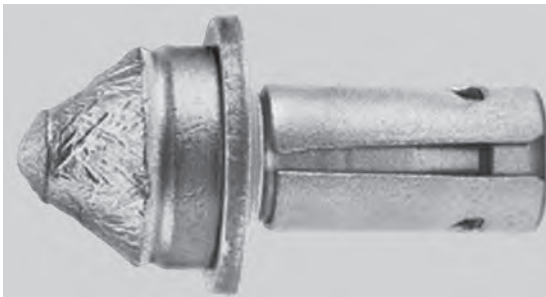

Figure 17

Figure 18 shows a tooth that has worked on soft materials and needs replaced.

If a tooth has been used on an overly soft material, the body will wear quicker than the tip, and the tip will end up snapping off. The altered tooth shape will increase also the tooth holder wear.

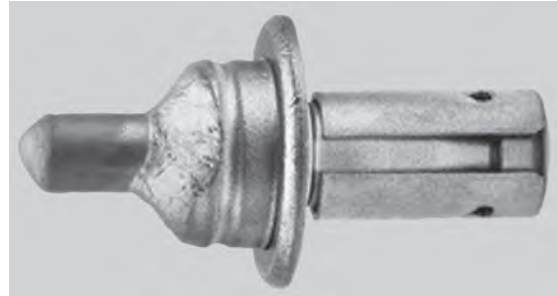

Figure 18

Figure 19 shows a tooth that has not been rotated properly and needs replaced.

Teeth subject to uneven wear will wear away too quickly. Wear of this kind is always symptomatic of failure to turn the tooth in its holder. The wear may be due to a worn tooth holder or presence of small particles of planed material between the tang of the tooth and the holder in which it is fitted. In this instance, clean the holder and lubricate with a water-based asphalt emulsifier (ex. Zep's #AR6690) or dish soap (ex. Dawn dish soap).



Figure 19

**NOTE:** The teeth shown in Figure 17, Figure 18, and Figure 19 are standard models. Similar concepts apply to all teeth models.



## 5. Maintenance

### 5.2 Every Hour Cont'd

#### Assessment Procedure

1. Visually inspect to establish the degree of wear.
2. Check that the teeth can turn freely in their holders.

Following the assessment, replace any broken tools or those showing excessive wear. Clean the holders of those which will not turn as shown in Figure 20.



Figure 20

#### Cleaning the Tooth

1. Remove the tooth which is not rotating (see "Removal" on page 31 under 5.7 When Required).
2. Clean the tang of the tooth and the holder in which it is fitted.
3. Lubricate with a water-based asphalt emulsifier (ex. Zep's #AR6690) or dish soap (ex. Dawn dish soap).
4. Refit the tooth in its holder.

**NOTE:** If the tooth rotates to some extent, lubrication with a water-based asphalt emulsifier (ex. Zep's #AR6690) or dish soap (ex. Dawn dish soap) can be performed without removing the tooth from its holder.

### ! IMPORTANT !

To make it easier to turn the teeth in their holders and, therefore, lengthen their working life, it is recommended to apply a water-based asphalt emulsifier (ex. Zep's #AR6690) or dish soap (ex. Dawn dish soap) to the rear of the tooth at the end of the working day, making sure the emulsifier seeps in between the tooth and the holder.



### WARNING



- Never let the drum rotate freely with new or freshly lubricated teeth, as they could come out of their holders due to centrifugal force.
- Never work with badly damaged and/or stuck teeth so as to avoid the tooth holders being damaged.

### 5.3 Every 8 Hours

#### Cleaning the Water Nozzles of the Optional Water Kit

1. Check the water nozzles [Figure 21, Item 1] located on the equipment and clean them if necessary.
2. When reinstalling them, pay attention to the orientations of the nozzles [Item 1], which must be installed with the water spray slit [Item 2] parallel to the drum rotation axis.

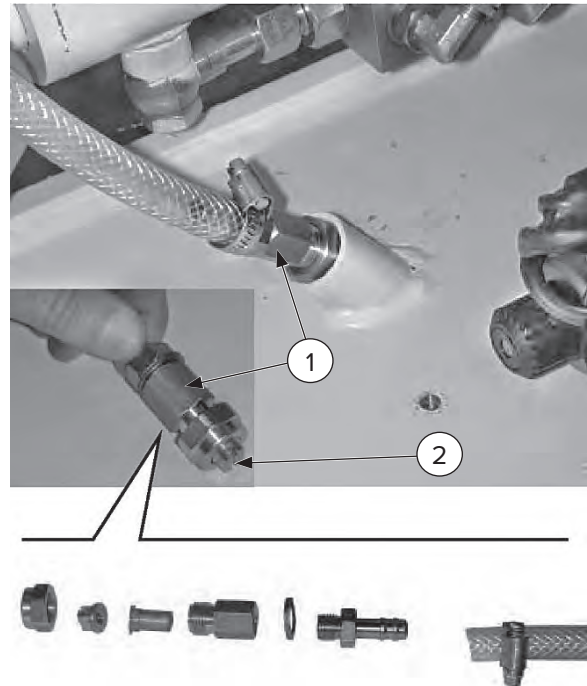

Figure 21



## 5. Maintenance

### 5.4 Every 50 Hours

#### Lubrication

Lubricate the joints of cylinders, dampener, slide adjustment pivot points, and the scraper drive screw as shown in Figure 22.

To lubricate them, inject and spread NLGI 2 – EP Lithium grease until all the worn-out grease comes out.



#### WARNING



Clean the grease nipples thoroughly before connecting the grease pump.

Before performing maintenance, place the equipment on the ground, shut down the prime mover, and remove the ignition key.

1. Grease each grease zerk.
2. Once greasing has been completed, remove all dirty grease which has been expelled to prevent damage from deposits of dirt and debris.

#### Check the Condition of the Hoses

Check the condition of the hoses and the crimping of the fittings. If a hose shows signs of aging, leaks, breakages, bulges, abrasions etc., it should be replaced.

1. Clean the working area to keep dirt from entering the hydraulic circuit.

2. Replacement must be carried out by qualified personnel, using all necessary PPE.
3. The new hose must be the same size and specifications as the previous one and be rated for the pressure indicated on the equipment's identification plate.

For tightening torques, see “Tightening Torques for Hoses” on page 45 under 7.2 Torque Specifications.

#### Equipment Cleaning

Use legally approved, neutral detergents. Clean the equipment with a high pressure jet of water.

### 5.5 Every 100 Hours

#### Structural Integrity Assessment

Clean the equipment carefully prior to the inspection. Inspect the bearing framework visually to check its integrity, focusing particularly on the welding. If any weakening or small cracks are noticed, contact Blue Diamond® Product Support for assistance.

#### Check Hardware Torque

Check that all the nuts and bolts are securely fastened and, if the parts have worked loose, tighten them.

For tightening torques, see “Standard Hardware and Lock Nuts” on page 43 under 7.2 Torque Specifications.

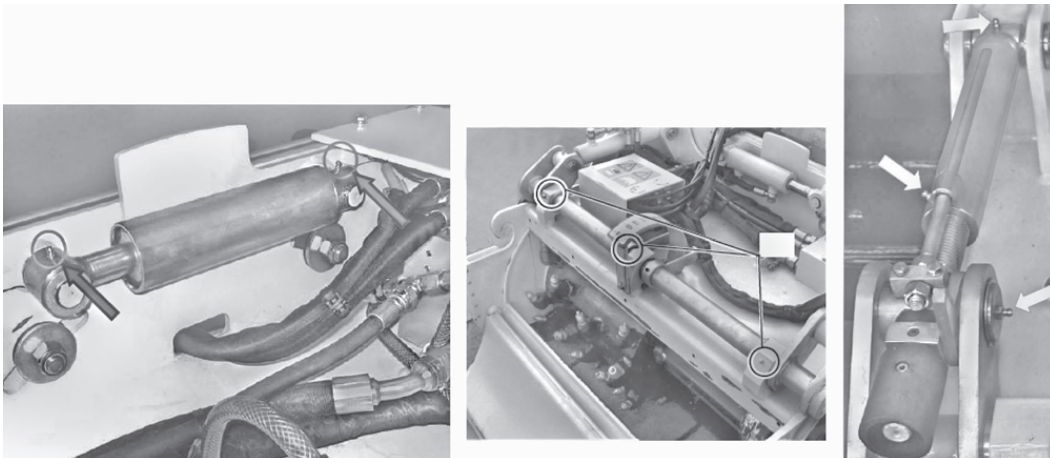

Figure 22

## 5. Maintenance

### 5.6 Every 200 Hours

#### Case Drain Line Safety Cover Inspection

To prevent damage to the motor due to high backpressure in the drain line, a safety cap [Figure 23, Item 1] has been fitted, which allows excess pressure to be relieved. When the drain line pressure exceeds 15 PSI (1 bar), the cover deforms and allows oil out, thereby releasing the excess pressure.

If any deformation and consequent leakage is noticed, check the continuous and instantaneous case drain line pressure (max. 15 PSI or 1 bar) and the circuit and replace the cover [Item 1] and the relative O-ring. Contact Blue Diamond® Product Support for more information.

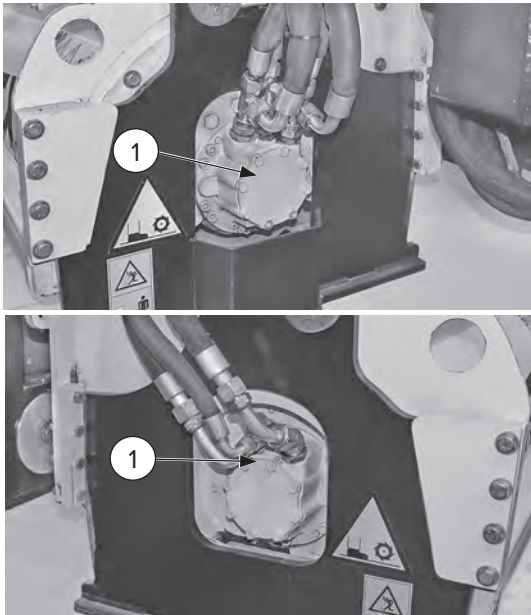

Figure 23

### ! IMPORTANT !

When inspecting or replacing the cover, clean both the cover and the surrounding area, ensuring that impurities do not enter the case drain line.

### ! WARNING !

The new fitted cap **MUST** have the same thickness as the original one.

### 5.7 When Required

#### Replacing the Skid Shoes

The skid shoes [Figure 24, Item 1] are made of special anti-wear steel and are fastened to the side of the cold planer [Item 2].

To replace them, contact Blue Diamond® Product Support for more information.

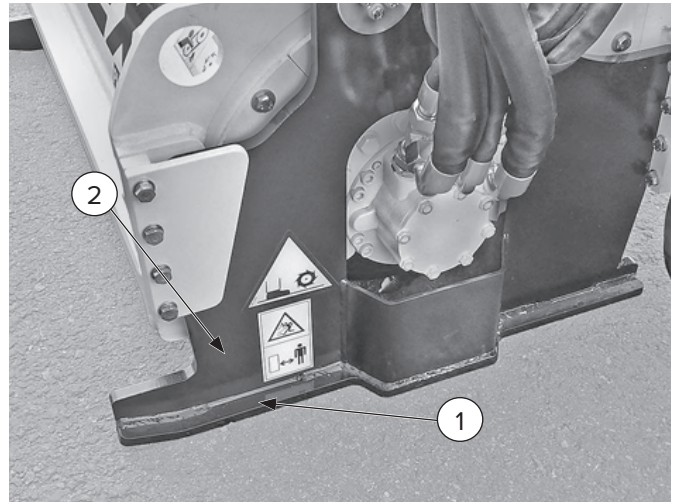

Figure 24

## 5. Maintenance

### 5.7 When Required Cont'd

#### Teeth Replacement

##### Removal

1. The teeth [Figure 25, Item 1] are held in the tooth holder by a retaining spring.
2. Position the tool [Item 2] supplied as shown below.
3. Hit the tool [Item 2] with a hammer to remove the teeth.

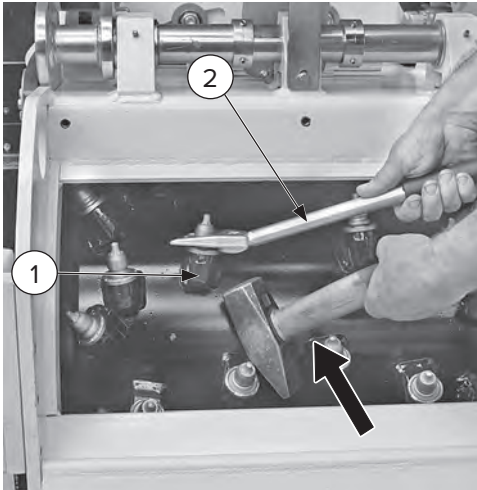
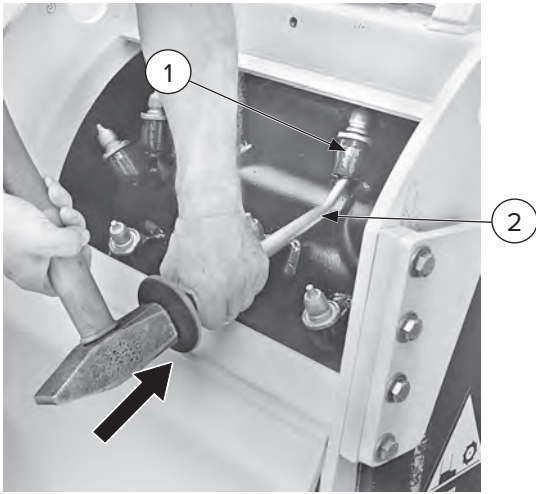

Figure 25

##### Assembly

1. Before fitting new teeth, clean and lubricate the holder with a water-based asphalt emulsifier (ex. Zep's #AR6690) or dish soap (ex. Dawn dish soap).
2. Insert the tooth [Figure 26, Item 1] into its holder using light blows with a copper hammer until the tooth top is fully inserted.
3. If a copper hammer is not available, place a short section of pipe with a 3/4" – 1" inside diameter or a piece of wood over the tooth. Lightly hammer the piece of pipe or wood. DO NOT directly hit the carbide tip with a hard hammer as this could cause damage.

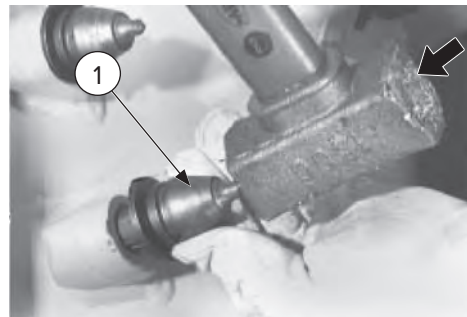

Figure 26

#### Special Maintenance

For uncommon maintenance procedures, contact Blue Diamond® Product Support for assistance.

### 5.8 Spare Parts & Accessories

Contact Blue Diamond® Product Support.

## 5. Maintenance

### 5.9 Troubleshooting

PROBLEM	CAUSE	SOLUTION
Slow planing, low performance	Teeth tips worn or broken	Replace the teeth, and clean their holders.
	Low flow and/or hydraulic pressure	Ensure all necessary connections have been made correctly for equipment operation. Contact the service department to check the flow and hydraulic pressure.
Vibrations	Loose or missing screws/bolts	Check the tightening torques of the screws/bolts (hydraulic motor, etc). Replace the missing screws.
	Worn or missing teeth	Replace the teeth, and clean their holders.
Noisy or jammed hydraulic motor	Problems inside the motor.	Contact Blue Diamond® Product Support.
The equipment does not turn	No hydraulic flow and/or pressure	Check the prime mover's hydraulic system.
	Quick couplings not fitted properly	Fit quick couplings properly.
	Other hydraulic or electric issues	Contact Blue Diamond® Product Support.
The cold planer does not slide	The electrical cable is disconnected	Connect the electrical cable.
	Quick couplings not fitted properly	Fit quick couplings properly.
	Selection valve dirty	Clean the valve.
Equipment turns too slowly or too fast	Incorrect equipment/prime mover coupling	Contact Blue Diamond® Product Support.
External oil leaks	Fittings are loose	Tighten fittings.
	Hosing damaged	Replace hosing.
	Couplings damaged	Replace couplings.
	Leaks from the hydraulic motor oil seals	Contact Blue Diamond® Product Support.
Safety cover swollen	Drainage line high backpressure and/or drain line missing or fitted incorrectly to the prime mover	Always connect the drain line directly to the prime mover's tank.
		Replace the cover and O-ring and to check the backpressure which should be < 15 PSI (1 bar). Contact Blue Diamond® Product Support for further assistance.
	Drainage line high backpressure and/or drain line hose damaged	Replace the hose.
		Replace the cover and O-ring and to check the backpressure which should be < 15 PSI (1 bar). Contact Blue Diamond® Product Support for further assistance.
	Sudden start-up of equipment with prime mover engine at maximum speed	Start up the equipment with the engine idling, then after a few seconds, accelerate slowly and gradually until the operating speed is reached.
		Replace the cover and O-ring and to check the backpressure which should be < 1 bar. Contact Blue Diamond® Product Support for further assistance.
Backpressure in prime mover's drain line is too high	Replace the cover and O-ring and to check the backpressure which should be < 15 PSI (1 bar). Contact Blue Diamond® Product Support for further assistance.	

## 6. Wire Harness Control Guide

### 6.1 Warning



Before using the Extreme Duty Series 2 Cold Planer, make sure that the electronic control unit (ECU) is supplied with a current of +12 volts. Green light indicator is flashing.

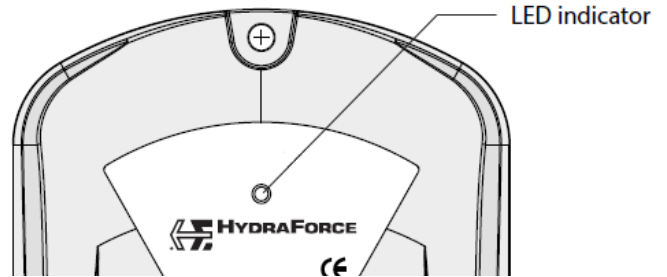

### 6.2 Universal Controller

PIN	DESCRIPTION
E	Shift the equipment to the left
F	Shift the equipment to the right
C + E	Decrease the working depth (left)
C + F	Increase the working depth (left)
D + E	Decrease the working depth (right)
D + F	Increase the working depth (right)
H + E	Clockwise tilt
H + F	Counterclockwise tilt
J	Activation of water pump (if equipped)

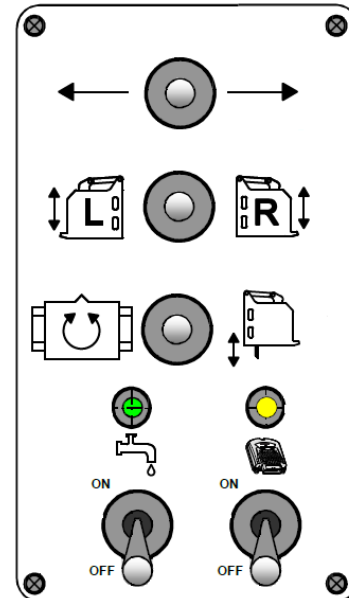



## 6. Wire Harness Controls

### 6.3 Bobcat

PIN	DESCRIPTION
G	Shift the equipment to the left
H	Shift the equipment to the right
D + G	Decrease the working depth (left)
D + H	Increase the working depth (left)
C + G	Decrease the working depth (right)
C + H	Increase the working depth (right)
F + G	Clockwise tilt
F + H	Counterclockwise tilt
E	Activation of water pump (if equipped)

**NOTE:** The The control for pin “E” is under relay. The first click will power the water pump. The second click will turn it off.



### 6.4 CASE & New Holland

PIN	DESCRIPTION
E	Shift the equipment to the left
F	Shift the equipment to the right
C + E	Decrease the working depth (left)
C + F	Increase the working depth (left)
D + E	Decrease the working depth (right)
D + F	Increase the working depth (right)
H + E	Clockwise tilt
H + F	Counterclockwise tilt
J	Activation of water pump (if equipped)

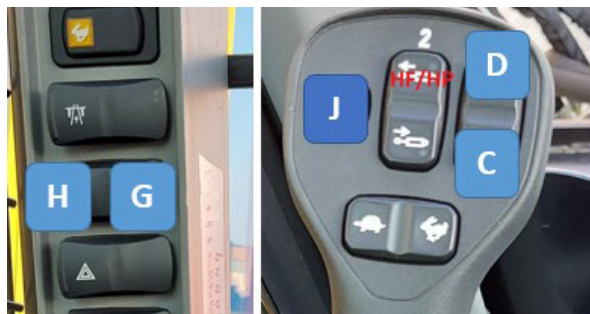
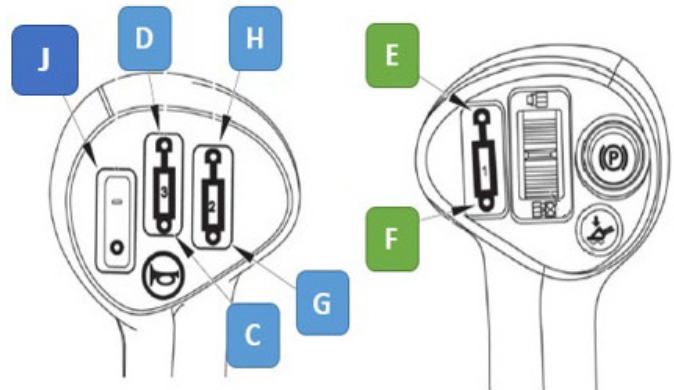



## 6. Wire Harness Controls

### 6.5 CAT D XPS / XHP

PIN	DESCRIPTION
D	Shift the equipment to the left
C	Shift the equipment to the right
D + E	Decrease the working depth (left)
C + E	Increase the working depth (left)
D + F	Decrease the working depth (right)
C + F	Increase the working depth (right)
D + A	Clockwise tilt
C + A	Counterclockwise tilt
C + D	Press the buttons simultaneously to activate the water pump (if equipped)

**NOTE:** The control for pin “C + D” is under relay. The first click will power the water pump. The second click will turn it off.

⚠
IMPORTANT
⚠

Before using the Extreme Duty Series 2 Cold Planer, make sure that the electronic control unit (ECU) is supplied with a current of +12 volts by activating the AUX 8 panel switch.

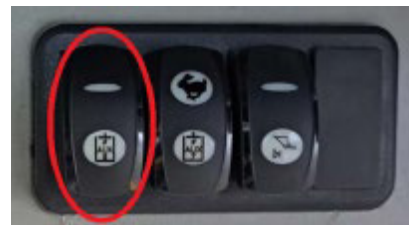
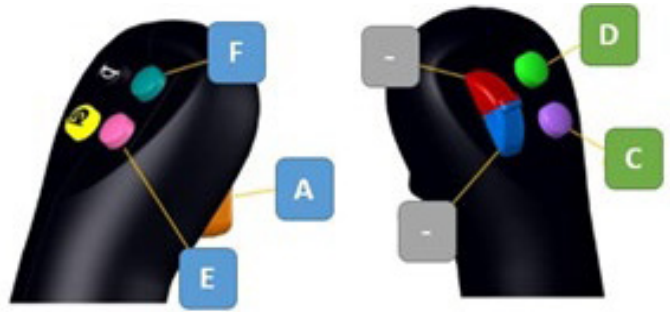

### 6.6 CAT D3 XPS / XHP X XE

PIN	DESCRIPTION
D	Shift the equipment to the left
C	Shift the equipment to the right
D + E	Decrease the working depth (left)
C + E	Increase the working depth (left)
D + F	Decrease the working depth (right)
C + F	Increase the working depth (right)
D + A	Clockwise tilt
C + A	Counterclockwise tilt
J (AUX 8)	Activation of water pump (if equipped)

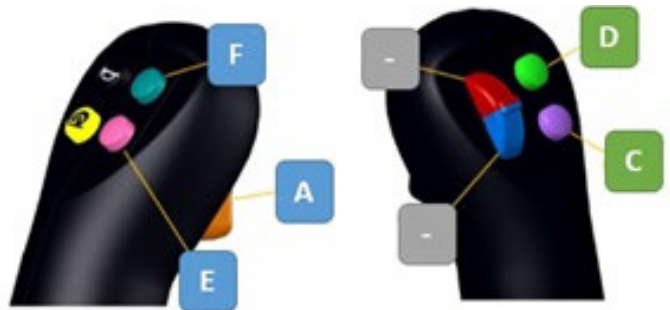

## 6. Wire Harness Controls

### 6.7 Gehl / Manitou / Mustang

PIN	DESCRIPTION
E	Shift the equipment to the left
F	Shift the equipment to the right
C + E	Decrease the working depth (left)
C + F	Increase the working depth (left)
D + E	Decrease the working depth (right)
D + F	Increase the working depth (right)
H + E	Clockwise tilt
H + F	Counterclockwise tilt
A	Activation of water pump (if equipped)

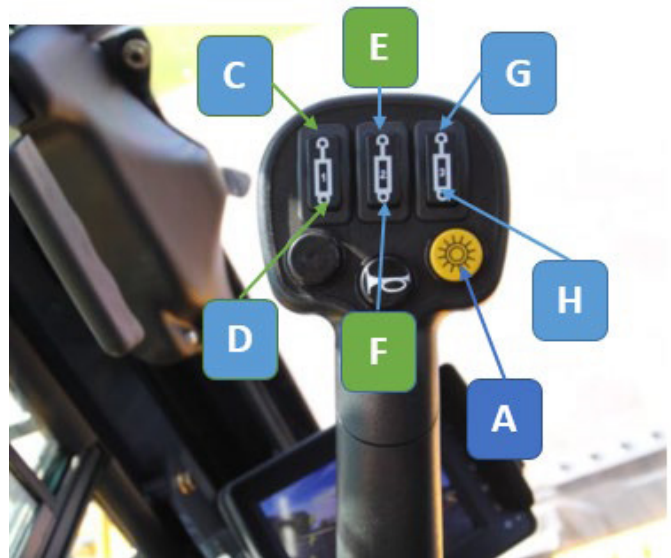

### 6.8 JCB / Volvo – Post 10 / 2010

PIN	DESCRIPTION
C	Shift the equipment to the left
D	Shift the equipment to the right
E + C	Decrease the working depth (left)
E + D	Increase the working depth (left)
F + C	Decrease the working depth (right)
F + D	Increase the working depth (right)
G + C	Clockwise tilt
G + D	Counterclockwise tilt
H	Activation of water pump (if equipped)

**NOTE:** The control for pin “H” is under relay. The first click will power the water pump. The second click will turn it off.

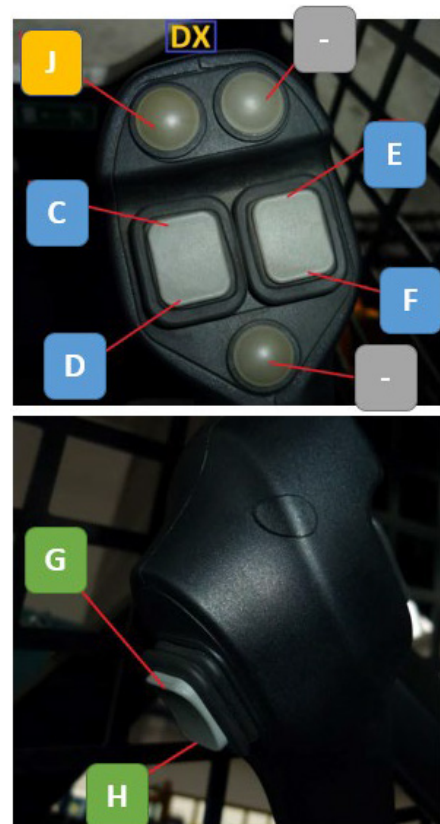

Before using the Extreme Duty Series 2 Cold Planer, make sure that the electronic control unit (ECU) is supplied with a current of +12 volts by activating the “J” switch.

## 6. Wire Harness Controls

### 6.9 JCB / Volvo – New Series 3.x

PIN	DESCRIPTION
C	Shift the equipment to the right
F	Shift the equipment to the left
C + E	Decrease the working depth (left)
C + F	Increase the working depth (left)
D + E	Decrease the working depth (right)
D + F	Increase the working depth (right)
H + E	Clockwise tilt
H + F	Counterclockwise tilt
A	Activation of water pump (if equipped)

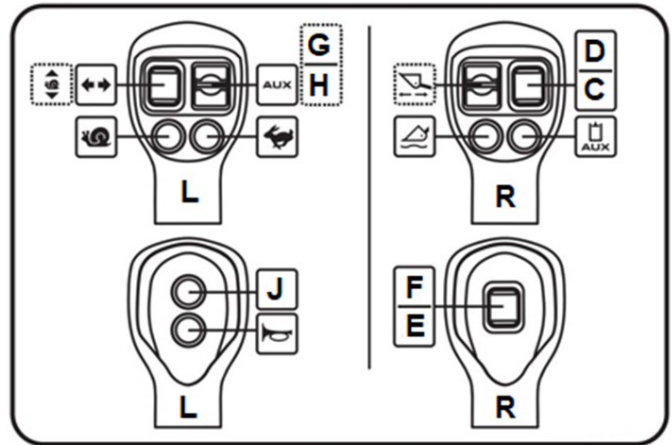

### 6.10 John Deere

PIN	DESCRIPTION
E	Shift the equipment to the left
D	Shift the equipment to the right
G + E	Decrease the working depth (left)
G + D	Increase the working depth (left)
C + E	Decrease the working depth (right)
C + D	Increase the working depth (right)
F + E	Clockwise tilt
F + D	Counterclockwise tilt
H	Activation of water pump (if equipped)



**NOTE:** The control for pin “H” is under relay. The first click will power the water pump. The second click will turn it off.

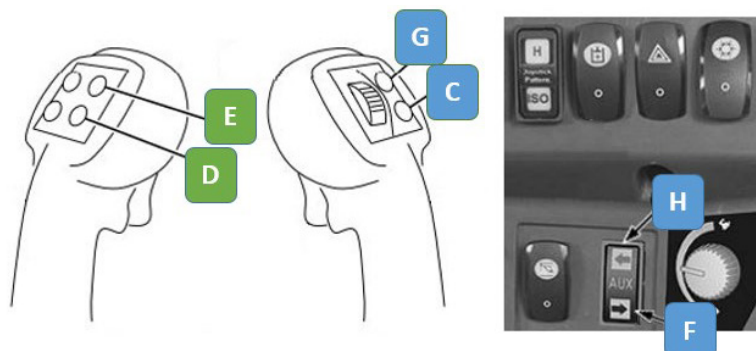

## 6. Wire Harness Controls

### 6.11 Kubota

PIN	DESCRIPTION
E	Shift the equipment to the left
F	Shift the equipment to the right
C + E	Decrease the working depth (left)
C + F	Increase the working depth (left)
D + E	Decrease the working depth (right)
D + F	Increase the working depth (right)
H + E	Clockwise tilt
H + F	Counterclockwise tilt
A	Activation of water pump (if equipped)



### 6.12 Takeuchi

PIN	DESCRIPTION
G	Shift the equipment to the left
H	Shift the equipment to the right
D + G	Decrease the working depth (left)
D + H	Increase the working depth (left)
C + G	Decrease the working depth (right)
C + H	Increase the working depth (right)
F + G	Clockwise tilt
F + H	Counterclockwise tilt
E	Activation of water pump (if equipped)



**NOTE:** The control for pin “E” is under relay. The first click will power the water pump. The second click will turn it off.



## 6. Wire Harness Controls

### 6.13 Wacker Neuson

PIN	DESCRIPTION
F	Shift the equipment to the left
E	Shift the equipment to the right
C + F	Decrease the working depth (left)
C + E	Increase the working depth (left)
D + F	Decrease the working depth (right)
D + E	Increase the working depth (right)
L + F	Clockwise tilt
L + E	Counterclockwise tilt
J	Activation of water pump (if equipped)

### ! IMPORTANT !

Before using the Extreme Duty Series 2 Cold Planer, make sure that the electronic control unit (ECU) is supplied with a current of +12 volts. Green light indicator is flashing. Select position “D” on the control panel (see machine’s Operator’s Manual).

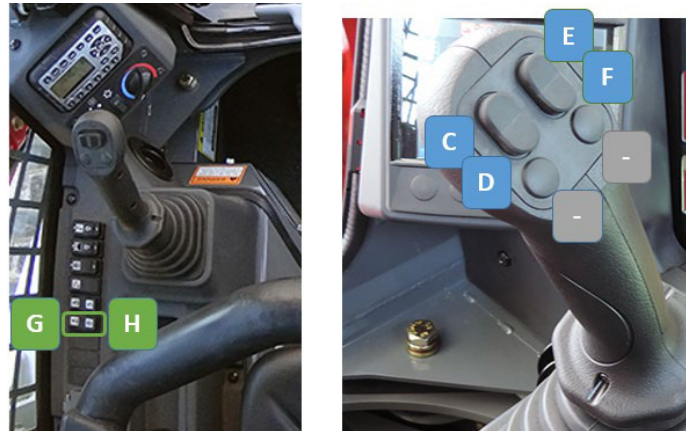

### 6.14 Yanmar

PIN	DESCRIPTION
E	Shift the equipment to the left
F	Shift the equipment to the right
D + E	Decrease the working depth (left)
D + F	Increase the working depth (left)
C + E	Decrease the working depth (right)
C + F	Increase the working depth (right)
X + D + F	Clockwise tilt
X + D + E	Counterclockwise tilt
X + C (G)	Activation of water pump (if equipped)



**NOTE:** The control for pin “X + C” is under relay. The first click will power the water pump. The second click will turn it off.



## 7. Specifications

### 7.1 Attachment Specifications

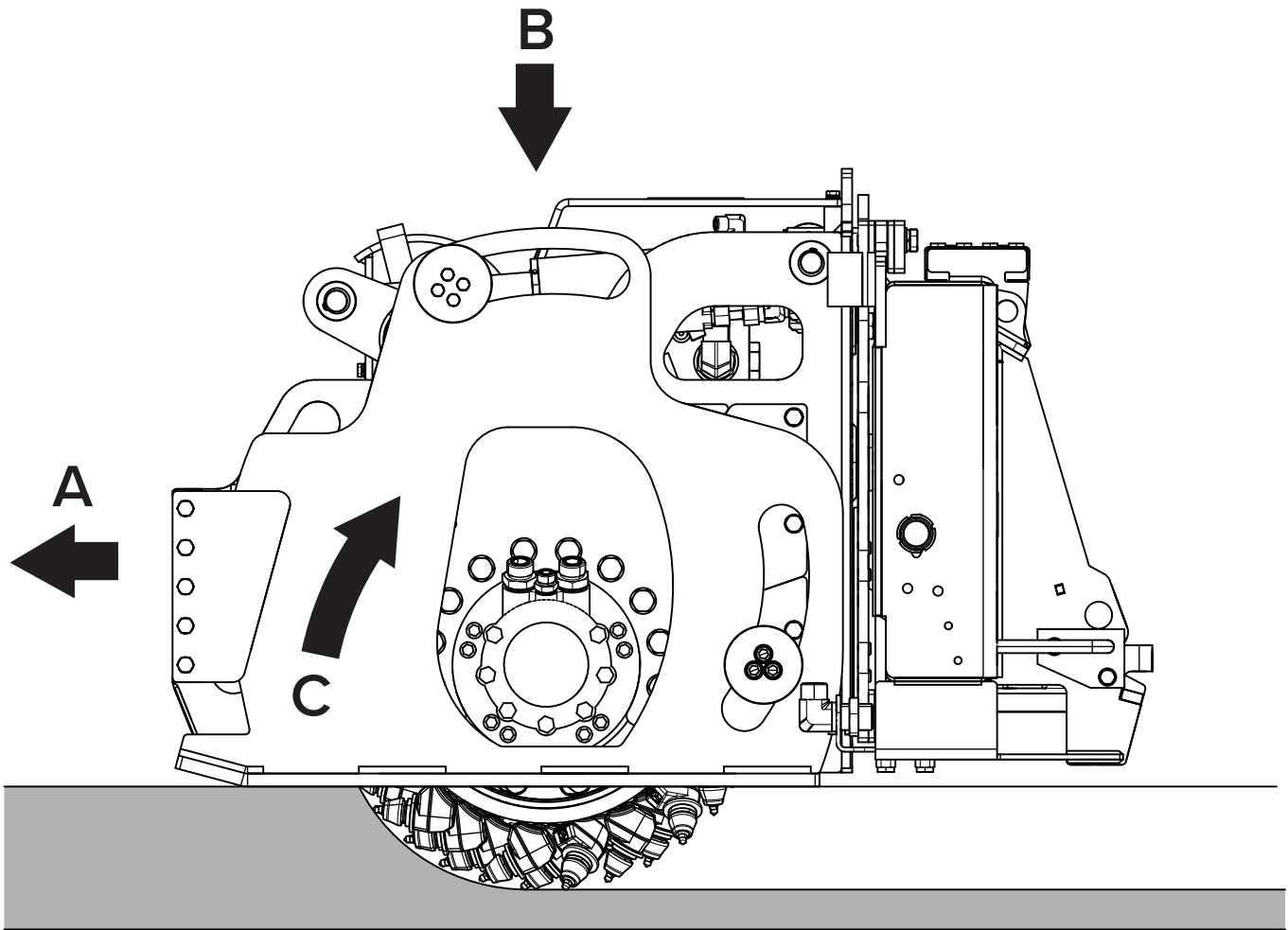

ALL MODELS	
A	Forward Movement
B	Ground Gripping Strength
C	Rotation Direction of the Cutter Drum

## 7. Specifications

### 7.1 Attachment Specifications Cont'd

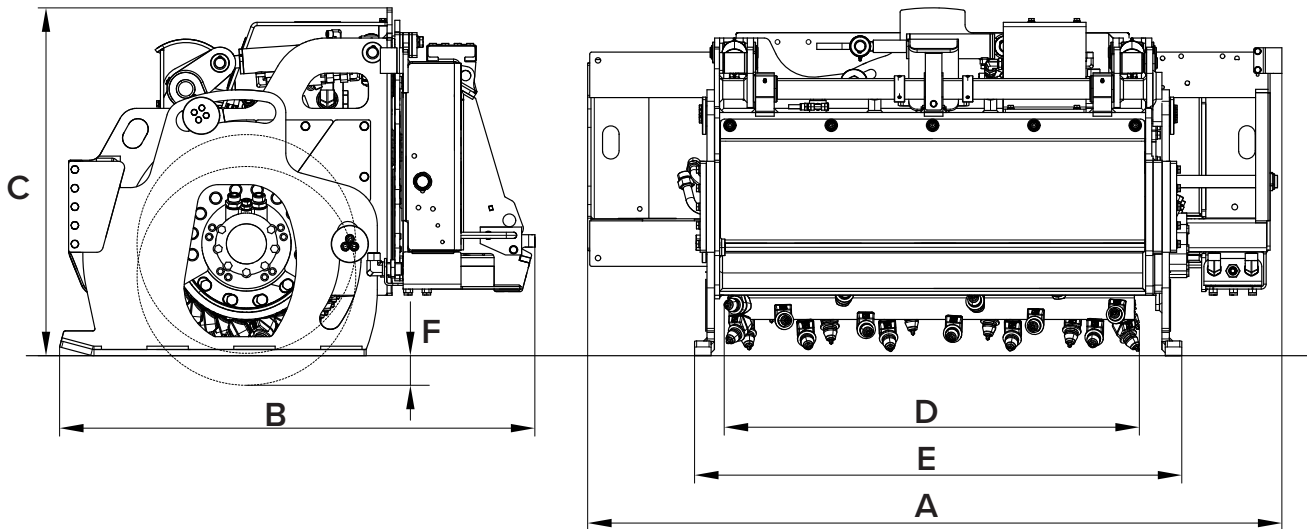

DESCRIPTION	160956	160957
Overall Width (A)	66 in. (1680 mm)	
Overall Length (B)	45 in. (1140 mm)	
Overall Height (C)	33 in. (830 mm)	
Cutting Width (D)	40 in. (1000 mm)	48 in. (1200 mm)
Chassis Width (E)	46.5 in. (1181 mm)	
Cutting Depth (F)	0–5 in. (0–130 mm)	
Maximum Tilt, Left & Right	8°	

## 7. Specifications

### 7.1 Attachment Specifications Cont'd

TECHNICAL CHARACTERISTIC	160956	160957
Operating Pressure	2321 – 4500 PSI (160 – 310 bar)	2321 – 4500 PSI (160 – 310 bar)
Oil Flow	29–50 GPM (110–190 l/min)	17–30 GPM (65–115 l/min)
Drum Revs	150–230 rpm	150–230 rpm
Max. Hydraulic Motor Power	60 kW	60 kW
	82 HP	82 HP
Weight*	2400 lbs (1090 kg)	2660 lbs (1210 kg)

\*Standard equipment configuration without accessories and universal coupling.

#### Example of how to calculate the hydraulic motor power:

##### *Imperial Units*

$$\frac{Q \text{ (GPM)} \times P \text{ (PSI)}}{1,714} = A \text{ (HP)}$$

##### *Metric Units*

$$\frac{Q \text{ (l / min)} \times P \text{ (bar)}}{450} = A \text{ (kW)}$$

##### Key

Q = Capacity P = Pressure A = Power

**NOTE:** The capacity and pressure rates stated in the equation above must be measured at exactly the same time, using a precision tool. The measurement must be carried out by a skilled person.

## 7. Specifications

### 7.2 Torque Specifications

#### Standard Hardware and Lock Nuts

BOLT TYPE	CLASS 4.8		CLASS 8.8 OR 9.8		CLASS 10.9		CLASS 12.9		
	Size	Lubricated	Dry	Lubricated	Dry	Lubricated	Dry	Lubricated	Dry
M6		4.8 N•m	6 N•m	9 N•m	11 N•m	13 N•m	17 N•m	15 N•m	19 N•m
		3.5 in / lb	4.5 in / lb	6.5 in / lb	8.5 in / lb	9.5 in / lb	12 in / lb	11.5 in / lb	14.5 in / lb
M8		12 N•m	15 N•m	22 N•m	28 N•m	32 N•m	40 N•m	37 N•m	47 N•m
		8.5 in / lb	11 in / lb	16 in / lb	20 in / lb	24 in / lb	30 in / lb	28 in / lb	35 in / lb
M10		23 N•m	29 N•m	43 N•m	55 N•m	63 N•m	80 N•m	75 N•m	95 N•m
		17 in / lb	21 in / lb	32 in / lb	40 in / lb	47 in / lb	60 in / lb	55 in / lb	70 in / lb
M12		40 N•m	50 N•m	75 N•m	95 N•m	110 N•m	140 N•m	130 N•m	165 N•m
		29 in / lb	37 in / lb	55 in / lb	70 in / lb	80 in / lb	105 in / lb	95 in / lb	120 in / lb
M14		63 N•m	80 N•m	120 N•m	150 N•m	175 N•m	225 N•m	205 N•m	260 N•m
		47 in / lb	60 in / lb	88 in / lb	110 in / lb	130 in / lb	165 in / lb	150 in / lb	190 in / lb
M16		135 N•m	175 N•m	260 N•m	330 N•m	375 N•m	475 N•m	440 N•m	560 N•m
		100 in / lb	125 in / lb	195 in / lb	250 in / lb	275 in / lb	350 in / lb	325 in / lb	410 in / lb
M18		135 N•m	175 N•m	260 N•m	330 N•m	375 N•m	475 N•m	440 N•m	560 N•m
		100 in / lb	125 in / lb	195 in / lb	250 in / lb	275 in / lb	350 in / lb	325 in / lb	410 in / lb
M20		190 N•m	240 N•m	375 N•m	475 N•m	530 N•m	675 N•m	625 N•m	800 N•m
		140 in / lb	180 in / lb	275 in / lb	350 in / lb	400 in / lb	500 in / lb	460 in / lb	580 in / lb
M22		260 N•m	330 N•m	510 N•m	650 N•m	725 N•m	925 N•m	850 N•m	1075 N•m
		190 in / lb	250 in / lb	375 in / lb	475 in / lb	540 in / lb	675 in / lb	625 in / lb	800 in / lb
M24		330 N•m	425 N•m	650 N•m	825 N•m	925 N•m	1150 N•m	1075 N•m	1350 N•m
		250 in / lb	310 in / lb	475 in / lb	600 in / lb	675 in / lb	850 in / lb	800 in / lb	1000 in / lb
M27		490 N•m	625 N•m	950 N•m	1200 N•m	1350 N•m	1700 N•m	1600 N•m	2000 N•m
		360 in / lb	450 in / lb	700 in / lb	875 in / lb	1000 in / lb	1250 in / lb	1150 in / lb	1500 in / lb
M30		675 N•m	850 N•m	1300 N•m	1650 N•m	1850 N•m	2300 N•m	2150 N•m	2700 N•m
		490 in / lb	625 in / lb	950 in / lb	1200 in / lb	1350 in / lb	1700 in / lb	1600 in / lb	2000 in / lb
M33		900 N•m	1150 N•m	1750 N•m	2200 N•m	2500 N•m	3150 N•m	2900 N•m	3700 N•m
		675 in / lb	850 in / lb	1300 in / lb	1650 in / lb	1850 in / lb	2350 in / lb	2150 in / lb	2750 in / lb
M36		1150 N•m	1450 N•m	2250 N•m	2850 N•m	3200 N•m	4050 N•m	3750 N•m	4750 N•m
		850 in / lb	1075 in / lb	1650 in / lb	2100 in / lb	2350 in / lb	3000 in / lb	2750 in / lb	3500 in / lb

## 7. Specifications

### 7.2 Torque Specifications Cont'd

#### Tightening Torques for Hose Fittings

DASH SIZE	BSPP DIAMETER	TORQUE
#4	1/4"	35 N•m
		310 in / lb
#6	3/8"	70 N•m
		620 in / lb
#8	1/2"	100 N•m
		885 in / lb
#12	3/4"	190 N•m
		1681 in / lb
#16	1"	300 N•m
		2655 in / lb
#20	1 1/4"	330 N•m
		2920 in / lb
#24	1 1/2"	400 N•m
		3540 in / lb

DASH SIZE	"W" (inch) DIAMETER	TORQUE
#6	9/16"	30 N•m
		266 in / lb
#8	3/4"	50 N•m
		443 in / lb
#10	7/8"	70 N•m
		620 in / lb
#12	1 1/16"	100 N•m
		885 in / lb
#14	1 3/16"	130 N•m
		1151 in / lb
#16	1 5/16"	145 N•m
		1283 in / lb
#20	1 5/8"	190 N•m
		1681 in / lb
#24	1 7/8"	240 N•m
		2124 in / lb



## 7. Specifications

### 7.2 Torque Specifications Cont'd

#### Tightening Torques for Hoses

With ORFS Fittings

DASH SIZE	"W" (inch) DIAMETER	TORQUE
#4	9/16"	25 N•m
		221 in / lb
#6	11/16"	40 N•m
		354 in / lb
#8	13/16"	55 N•m
		487 in / lb
#10	1"	100 N•m
		761 in / lb
#12	1 3/16"	125 N•m
		1106 in / lb
#16	1 7/16"	165 N•m
		1460 in / lb
#20	1 11/16"	200 N•m
		1770 in / lb
#24	2"	245 N•m
		2168 in / lb

With JIC 37° Fittings

DASH SIZE	"W" (inch) DIAMETER	TORQUE
#6	9/16"	30 N•m
		266 in / lb
#8	3/4"	50 N•m
		443 in / lb
#10	7/8"	70 N•m
		487 in / lb
#12	1 1/16"	100 N•m
		761 in / lb
#14	1 3/16"	130 N•m
		1151 in / lb
#16	1 5/16"	145 N•m
		1283 in / lb
#20	1 5/8"	190 N•m
		1681 in / lb
#24	1 7/8"	240 N•m
		2124 in / lb

With BSPP Fittings

DASH SIZE	"W" (inch) DIAMETER	TORQUE
#4	1/4"	15 N•m
		133 in / lb
#6	3/8"	28 N•m
		248 in / lb
#8	1/2"	60 N•m
		531 in / lb
#10	5/8"	70 N•m
		487 in / lb
#12	3/4"	110 N•m
		974 in / lb
#16	1"	140 N•m
		1239 in / lb
#20	1 1/4"	190 N•m
		1681 in / lb
#24	1 1/2"	245 N•m
		2168 in / lb

**This page intentionally  
left blank**



## Warranty

### MANUFACTURER'S LIMITED WARRANTY

BLUE DIAMOND® ATTACHMENTS, a manufacturer of quality attachments, warrants new BLUE DIAMOND® ATTACHMENTS products and/or attachments at the time of delivery to the original purchaser, to be free from defects in material and workmanship when properly set up and operated in accordance with the recommendations set forth by BLUE DIAMOND® ATTACHMENTS, LLC.

BLUE DIAMOND® ATTACHMENTS liability for any defect with respect to accepted goods shall be limited to repairing the goods at a BLUE DIAMOND® ATTACHMENTS designated location or at an authorized dealer location, or replacing them, as BLUE DIAMOND® ATTACHMENTS shall elect. The above shall be in accordance with BLUE DIAMOND® ATTACHMENTS warranty adjustment policies. BLUE DIAMOND® ATTACHMENTS obligation shall terminate twelve (12) months for the Extreme Duty Series 2 Cold Planer after the delivery of the goods to original purchaser.

This warranty shall not apply to any machine or attachment which shall have been repaired or altered outside the BLUE DIAMOND® ATTACHMENTS factory or authorized BLUE DIAMOND® ATTACHMENTS dealership or in any way so as in BLUE DIAMOND® ATTACHMENTS judgment, to affect its stability or reliability, nor which has been subject to misuse, negligence or accident beyond the company recommended machine rated capacity.

### WARRANTY CLAIM

To submit a warranty claim, a claim must be filed with BLUE DIAMOND® ATTACHMENTS before work is performed. The BLUE DIAMOND® PRODUCT SUPPORT TEAM will advise repairs and applicable parts exchanges. Tampering with the failed part may void the warranty. This warranty does not include freight or delivery charges incurred when returning machinery for servicing. Dealer mileage, service calls, and pickup/delivery charges are the customers' responsibility.

### EXCLUSIONS OF WARRANTY

Except as otherwise expressly stated herein, BLUE DIAMOND® ATTACHMENTS makes no representation or warranty of any kind, expressed or implied, AND MAKES NO WARRANTY OF MERCHANTABILITY IN RESPECT TO ITS MACHINERY AND/OR ATTACHMENTS ARE FIT FOR ANY PARTICULAR PURPOSE. BLUE DIAMOND® ATTACHMENTS shall not be liable for incidental or consequential damages for any breach or warranty, including but not limited to inconvenience, rental of replacement equipment, loss of profits or other commercial loss. Upon purchase, the buyer assumes all liability for all personal injury and property resulting from the handling, possession, or use of the goods by the buyer.

No agent, employee, or representative of BLUE DIAMOND® ATTACHMENTS has any authority to bind BLUE DIAMOND® ATTACHMENTS to any affirmation, representation, or warranty concerning its machinery and/or attachments except as specifically set forth herein.

This warranty policy supersedes any previous documents. Please see [bluediamondattachments.com/warranty-policies](http://bluediamondattachments.com/warranty-policies) for the most up to date warranty information.

**NOTE:** Blue Diamond® Attachments is a trademark of BLUE DIAMOND® ATTACHMENTS



**QUALITY | DEPENDABILITY | INTEGRITY**

Blue Diamond® Attachments  
4512 Anderson Road, Knoxville, TN 37918  
888-376-7027