

42" Severe Duty Series 2 Mini Excavator Brush Cutter

Operation and Maintenance Manual



Register your
WARRANTY
within 30 days
of purchase



888-376-7027 | BlueDiamondAttachments.com



BD-092

Introduction: Owner Information

Thank you for your decision to purchase a Blue Diamond® Standard Duty Tractor Rototiller. To ensure maximum performance of your equipment, it is mandatory that you thoroughly study the Operator's manual and follow the recommendations. Proper operation and maintenance are essential to maximize equipment life and prevent personal injury.

Operate and maintain this equipment in a safe manner and in accordance with all applicable local, state, and federal codes, regulations and /or laws. Follow all on-product labeling and instructions.

Make sure that all personnel have read this Operator's Manual and thoroughly understand safe and correct operating, installation and maintenance procedures.

Blue Diamond is continually working to improve its products. Blue Diamond reserves the right to make any improvements or changes as deemed practical and possible without incurring any responsibility or obligation to make any changes or additions to equipment sold previously.

Although great care has been taken to ensure the accuracy of this publication, Blue Diamond makes no warranty or guarantee of any kind, written or expressed, implied or otherwise with regard to the information contained within this manual. Blue Diamond assumes no responsibility for any errors that may appear in this manual and shall not be liable under any circumstances for incidental, consequential or punitive damages in connection with, or arising from the use of this manual.

Keep this manual available for frequent reference. All new operators or owners must review the manual before using the equipment and annually thereafter. Contact your Blue Diamond Attachments Dealer for assistance, information, or additional copies of the manual. Contact www.bluediamondattachments.com or call 888-376-7027 for a complete list of dealers in your area.

Serial Number Location:

Please record attachment information in the space provided for future reference.

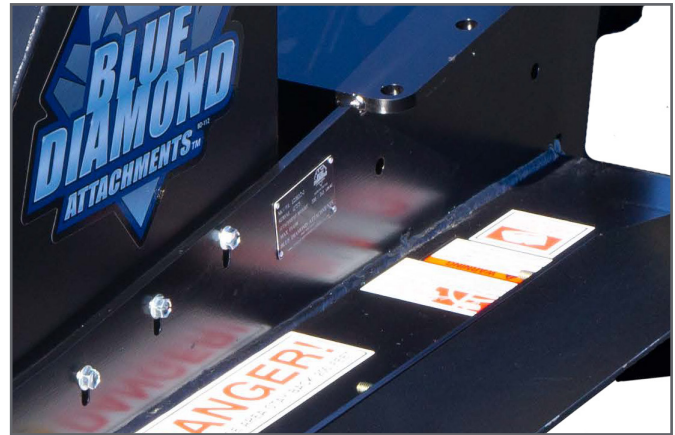

Figure 1

Model Number: _____

Serial Number: _____

Dealer Name: _____

Dealer Number: _____

Date of Purchase: _____

The serial number plate is located as shown in [Figure 1].

Always use your serial number when requesting information or when ordering parts.

NOTE: The directions left, right, front and rear, as mentioned throughout this manual, are as viewed from the operator's position.

Table of Contents

1. Introduction.....	4
1.1 Attachment Identification.....	4
2. Safety	5-7
2.1 General Safety Information.....	5
2.2 Qualified Operators.....	5
2.3 Safety Guidelines.....	6
3. Operation	8-16
3.1 General Information.....	8
3.2 Attachment Inspection.....	9
3.3 Attachment Installation.....	10
3.4 Operating the Attachment	13
3.5 Blade Reversal Instructions	17
4. Maintenance	18-21
4.1 Service Schedule	18
4.2 Drive Assembly	19
4.3 Blade Assembly.....	20
4.4 Cleaning the Attachment	21
5. Troubleshooting.....	22
6. Parts.....	23-33
6.1 Hydraulic Piston Motor	23
6.2 Brush Cutter Deck	24
6.3 Decal Identification and Location.....	26
7. Specifications.....	27-28
7.1 Attachment Specifications.....	27
7.2 Torque Specifications	28
8. Warranty	29

1. Introduction

1.1 Attachment Identification

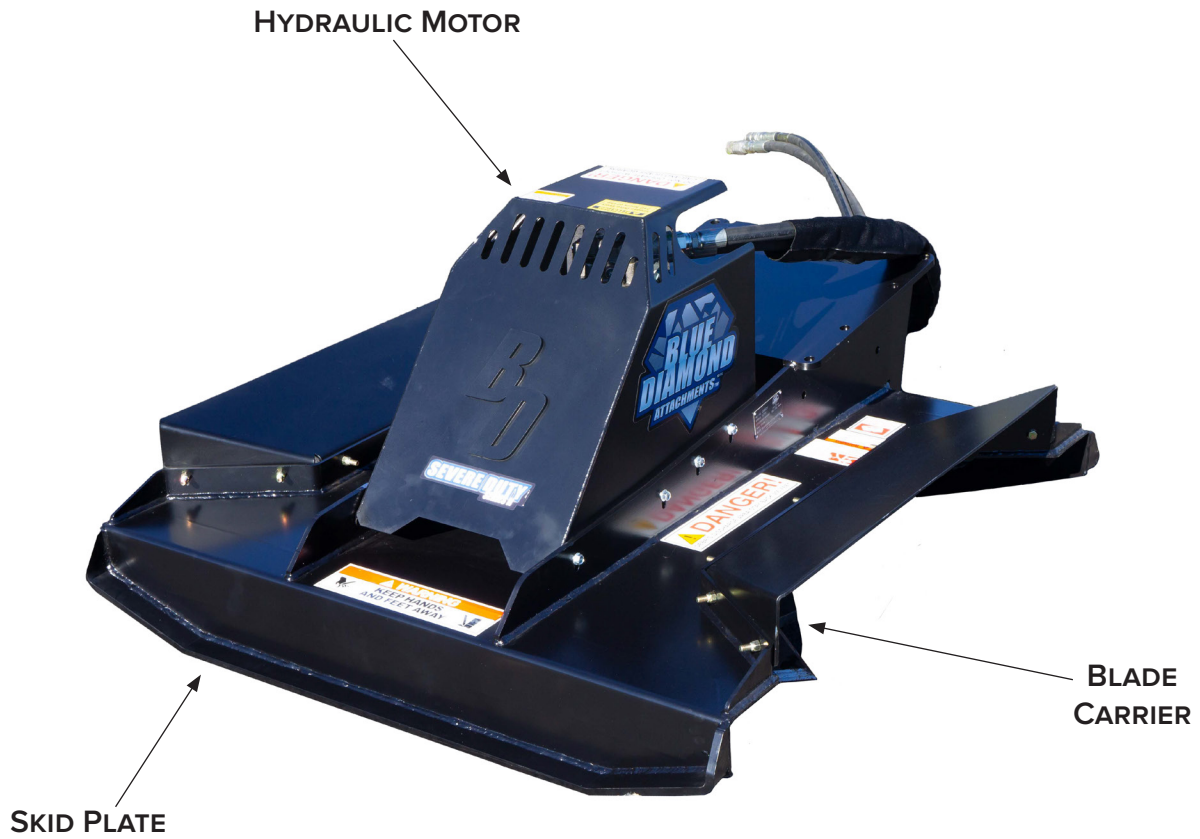

2. Safety

2.1 General Safety Information



This SAFETY ALERT SYMBOL identifies important safety messages on the equipment and in the owner's manual. When you see this symbol, be alert to the possibility of personal injury and carefully read the message that follows.



The signal word **DANGER** on the machine and in the manuals indicates a hazardous situation which, if not avoided, will result in death or serious injury.



The signal word **WARNING** on the machine and in the manuals indicates a potentially hazardous situation which, if not avoided, could result in death or serious injury.



The signal word **CAUTION** on the machine and in the manuals indicates a potentially hazardous situation which, if not avoided, may result in minor or moderate injury. It may also be used to alert against unsafe practices.



The signal word **IMPORTANT** identifies procedures which must be followed to avoid damage to the machine.

2.2 Qualified Operators

Safe Operation Needs a Qualified Operator



AVOID SERIOUS INJURY OR DEATH

Operators must receive instructions before operating the machine. Untrained operators can cause serious injury or death.

For an operator to be qualified, he or she must not use drugs or alcoholic drinks which impair alertness or coordination while working. An operator who is taking prescription drugs must get medical advice to determine if he or she can safely operate a machine and the equipment.

Operator Training

- Check the rules and regulations at your location. The rules may include an employer's work safety requirements. Regulations may apply to local driving requirements or use of a Slow Moving Vehicle (SMV) emblem. Regulations may identify a hazard such as a utility line.
- The new operator must start in an area without bystanders and use all the controls until he or she can operate the machine safely under all conditions of the work area.

2. Safety

2.3 Safety Guidelines

Operating Safety

- Read and follow instructions in this manual and the machine's Operator's Manual before operating.
- Under no circumstances should young children be allowed to work with this equipment.
- This equipment is dangerous to persons unfamiliar with its operation.
- Check for overhead and / or underground lines before operating equipment (if applicable).
- In addition to the design and configuration of equipment, hazard control and accident prevention are dependent upon the awareness, concern, prudence and proper training of personnel involved in the operation, transport, maintenance and storage of equipment.
- Check that the attachment is securely fastened to the machine.
- Make sure all the machine controls are in the NEUTRAL before starting the machine.
- Operate the equipment only from the operator's position.
- Operate the equipment according to the Operator's Manual.
- When learning to operate the equipment, do it at a slow rate in an area clear of bystanders.
- DO NOT permit personnel to be in the work area when operating the equipment.
- The equipment must be used ONLY on approved machines.
- DO NOT modify the equipment in any way. Unauthorized modification may impair the function and / or safety and could affect the life of the equipment.
- DO NOT make any adjustments or repairs on the equipment while the machine is running.
- Keep shields and guards in place. Replace if damaged.
- DO NOT operate equipment in poor visibility conditions such as fog, darkness, or any conditions that limit clear visibility less than 300 feet (100 m) in front of and to the sides of the equipment.
- When conditions make it necessary to slow ground speed, shift to a lower gear rather than reducing engine speed. The engine will maintain rated speed and keep cutter running at optimum cutting speed.
- DO NOT operate in a work area that has not been inspected for foreign debris and obstacles.
- Remove any foreign objects and clearly mark any objects that cannot be removed.
- Wear safety glasses, gloves, hearing protection and other protective clothing when required.

2. Safety

Machine Requirements and Capabilities

- The machine's operator's cab should be equipped with a thermoplastic polycarbonate or similar material front window, and similar protection on the sides of the operator's cab before operating the equipment.
- Keep bystanders clear of moving parts and the work area. Keep children away.
- Do Not exceed 3000 psi (206 bar) operating pressure.
- Use caution on slopes and near banks and ditches to prevent overturn.

Fire Prevention Safety

- Flammable debris (leaves, grass, etc.) must be removed regularly. If flammable debris is allowed to accumulate, it can cause a fire hazard. Clean often to avoid this accumulation.
- The equipment's hydraulic motor compartment must be inspected every day and cleaned if necessary to prevent fire hazards and overheating.
- All fuels, most lubricants, and some coolant mixtures are flammable. Flammable fluids that are leaking or spilled onto hot surfaces or onto electrical components can cause a fire.

Transporting Safety

- Comply with state and local laws governing highway safety and movement of machinery on public roads.
- Check local laws for all highway lighting and marking requirements.
- Always yield to oncoming traffic and move to the side of the road so any following traffic may pass.
- Never allow riders on either machine or equipment.
- If transporting the equipment on a truck or trailer, make sure the equipment is properly secured to the transport vehicle.

Hydraulic System

- Check hydraulic tubes, hoses and fittings for damage and leakage. Never use open flame or bare skin to check for leaks. Hydraulic tubes and hoses must be properly routed and have adequate support and secure clamps. Tighten or replace any parts that show leakage.
- Always clean fluid spills. Do not use gasoline or diesel fuel for cleaning parts. Use commercial nonflammable solvents.

3. Operation

3.1 General Information

Pre-Operation Inspection

Before operating the Series 2 Mini-Excavator Brush Cutter for the first time and each time thereafter, use the following list as a guideline during equipment inspection.



WARNING



AVOID SERIOUS INJURY OR DEATH

- Disengage machine's auxiliary hydraulics, engage the machine's parking brake, stop the engine and make sure all rotating components are completely stopped before connecting, disconnecting, adjusting or cleaning equipment.
- Always keep shields and all guards in place when using the equipment.
- Disengage machine's auxiliary hydraulics for road travel.
- Keep hands, feet and clothing away from rotating parts.

- Fully clean the attachment. See "Cleaning The Attachment" on page 21.
- Lubricate the attachment per the schedule outline in the Maintenance Section. See "Service Schedule" on page 18.
- Check the brush cutter mounting plate for damage. Check for loose or missing parts. Repair as needed before operation.
- Check that blades are in good condition. Sharpen or replace them, if necessary.
- Check that all shields and guards are in place.
- Check for loose bolts and tighten them if necessary.

- Check all welds on the attachment for wear and damage each time the attachment is removed from the machine.
- Check for damaged or missing safety decals. Replace if necessary.
- Inspect the machine's mounting frame. (See the machine's Operator's Manual for inspecting the mounting frame). Replace any parts that are damaged, bent or missing. Keep all fasteners tight. Look for cracked welds.



WARNING



Leaking fluids under pressure can enter the skin and cause serious injury or death. Immediate medical attention is required.

Wear goggles. Use cardboard to check for leaks.

- Check condition of all hydraulic components for leaks. Repair as required.

NOTE: Do not operate with hydraulic leaks.

- Verify that the brush cutter is properly connected to the machine.

3. Operation

3.2 Attachment Inspection

Daily Inspection

NOTE: Inspect the attachment by performing a walk around daily before and after use. Use the following inspection checklist as a guideline.

Check the following items every 10 hours of operation:

- Verify that the brush cutter is properly connected to the machine.
- Check that all shields and guards are in place.
- Check hydraulic lines, connections and fittings for hydraulic oil leaks. Repair or replace damaged parts if necessary.
- Check the brush cutter mounting hardware for wear or damage. Inspect the pins and mount (on the attachment) for wear or damage. Repair or replace damaged parts if necessary.

Weekly Inspection

Check the following items every 40 hours of operation:

- Check blade bolts for correct torque 1440 ft/lb.(1952 N•m).
- Check all bolts for tightness.
3/8" bolts to 50 ft/lb (67.5 N•m) torque.
1/2" bolts to 100 ft/lb (135 N•m) torque.
- Inspect the deck for cracks, bends, or damage.

Monthly Inspection

- Inspect the blades for cracks, bends, or excessive wear.
- Check skid plates for wear.
- Check that all bolts are tight.
- Check blades and mounting plate for cracks or damage. Replace if necessary.
- Check blade mounting hardware for correct torque 1440 ft/lb. (1952 N•m). Check mounting plate hardware.
- Check deck, shields and guards. Repair if damaged or replace if necessary.
- Check for damaged or missing decals. Replace if necessary.
- Check for damaged or leaking hydraulic hoses or fittings. Replace if necessary.
- Clean all debris, leaves, grass and flammable material from deck area and under covers.
- Lubricate as required.



WARNING



AVOID SERIOUS INJURY OR DEATH

Before servicing the attachment:

- Always park on a flat level surface.
- Lower dipperstick and place attachment flat on the ground.
- Place all controls in **NEUTRAL**.
- Engage the park brake.
- Wait for all moving parts to stop.
- Stop the engine and remove the key.

SEE MACHINE'S OPERATOR'S MANUAL FOR ADDITIONAL INFORMATION.

3. Operation

3.3 Attachment Installation

IMPORTANT



See the machine's Operator's Manual for detailed information on operating the loader.

Entering The Operator's Position

Use the grab handles, tracks, and safety tread (on the machine) to enter the operator's position.

When in the operator's position, fasten the seat belt.

See the Mini-Excavator operator's manual to correctly operate the machine.

Leaving The Operator's Position

WARNING

AVOID SERIOUS INJURY OR DEATH

Before leaving the operator's position:

- Always park on a flat level surface.
- Lower dipperstick and place attachment flat on the ground.
- Place all controls in **NEUTRAL**.
- Engage the park brake.
- Wait for all moving parts to stop.
- Stop the engine and remove the key.

SEE MACHINE'S OPERATOR'S MANUAL FOR ADDITIONAL INFORMATION.

Park the machine / attachment on a flat level surface.

Place all controls in neutral, engage the park brake, stop the engine and wait for all moving parts to stop. Leave the operator's position.

Use the grab handles, tracks, and safety tread (on the machine) to exit the operator's position.

Connecting Attachment To The Machine

WARNING



CRUSH HAZARD

- Before moving the machine, look in all directions and make sure no bystanders, especially small children are in the work area. Do not allow anyone between the machine and attachment when approaching the attachment for connecting.
- Keep fingers and hands out of pinch points when connecting and disconnecting the attachment.

Before connecting to the attachment, inspect the machine's mounting plate. (See the machine's Operator's Manual for inspecting the mounting frame).

Enter the operator's position. See "Entering The Operator's Position" on page 10.

3. Operation

Connecting Attachment to the Machine Cont'd

Bracket Interchange Installation

Order the appropriate bracket interchange from your local Blue Diamond® Attachments dealer by supplying the brand and model information of your machine.

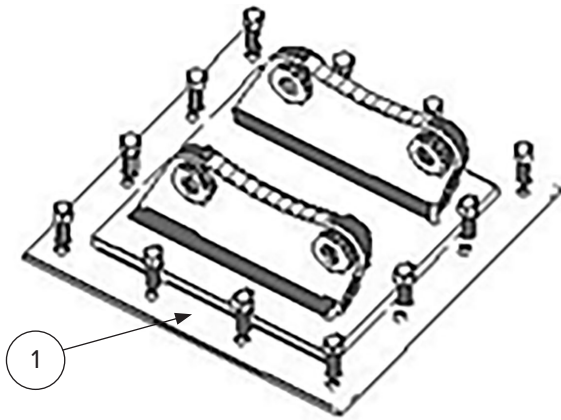

Figure 2

The bracket interchange (Item 1) [Figure 2] is secured to the attachment with 12 bolts.

Use an appropriate lifting device and slings to place the bracket interchange onto the attachment.

Align the holes between the bracket interchange and deck and install the appropriate hardware.

Torque hardware to the specification detailed in the “Specifications” section of this manual on page 28.



Figure 3

Position the excavator at the rear of the attachment.

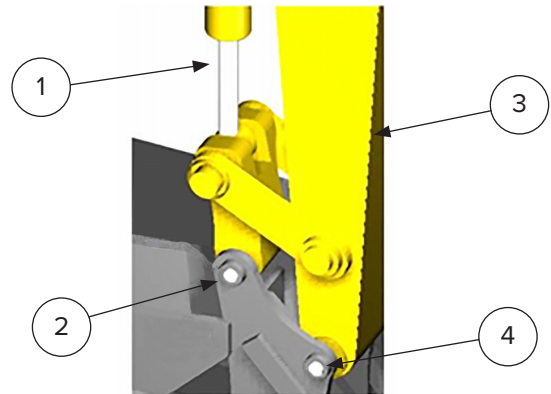

Figure 4

Extend the tool cylinder (Item 1) and paddle until the pin position (Item 2) [Figure 4] is aligned.

Leave the operator’s position. See “Leaving The Operator’s Position” on page 10.



Install the pin through the attachment and paddle and secure with appropriate hardware.

Enter the operator’s position. See “Entering The Operator’s Position” on page 10.

Adjust the height of the dipperstick (Item 3) to align with the pin position (Item 4) [Figure 4].

Leave the operator’s position. See “Leaving The Operator’s Position” on page 10.

Install the pin through the attachment and paddle and secure with appropriate hardware.

**WARNING**

AVOID SERIOUS INJURY OR DEATH

The locking pins must extend through the holes in the attachment mounting frame.

Failure to secure locking pins can allow attachment to come off.

SEE MACHINE’S OPERATOR’S MANUAL FOR ADDITIONAL INFORMATION.

3. Operation

Connecting Hydraulic Hoses



IMPORTANT



- Thoroughly clean the quick couplers before making connections. Dirt can quickly damage the hydraulic system.

Remove dirt or debris from the male and female couplers. Visually inspect the couplers for corroding, cracking, damage, or excessive wear. Replace as needed.

Connect the attachment hydraulic hoses to the machine. Pull on each hose to verify full connection is made.

Disconnecting Hydraulic Hoses



WARNING



AVOID SERIOUS INJURY OR DEATH

Hydraulic fluid, tubes, fittings, and quick couplers can get hot during operation. Be careful when connecting and disconnecting hydraulic hoses.

Relieve auxiliary hydraulic pressure. (See the machine's Operator's Manual for correct procedure.)

Disconnect attachment hydraulic hoses from the machine.

Disconnecting Attachment From the Machine

Relieve auxiliary hydraulic pressure. (See the machine's Operator's Manual for correct procedure.)

Park the machine and attachment on a flat level surface. Lower the attachment flat on the ground.

Leave the operator's position. See "Leaving The Operator's Position" on page 10.

Disconnect attachment hydraulic hoses from the machine.

Remove hardware securing the pins and remove the pins from the paddle and attachment.

Enter the operator's position. See "Entering The Operator's Position" on page 10.

Raise the dipperstick to clear the attachment.

Drive the machine slowly backward, away from the attachment.

3. Operation

3.4 Operating the Attachment

Machine Requirements



DANGER



**FLYING DEBRIS OR OBJECTS WILL CAUSE
SERIOUS INJURY OR DEATH**

To protect the operator from any flying debris or objects, it is important that the machine's operator's cab should be equipped with a thermoplastic polycarbonate or similar material front window, and similar protection on the sides of the operator's cab before operating the Mini Excavator Brush Cutter.

Mini Excavator Brush Cutter

- It's recommended that the machine be equipped with a thermoplastic polycarbonate or similar material front window, and similar protection on the sides of the operator's cab.
- The machine must be equipped with auxiliary hydraulics with a hydraulic flow of 16 – 26 GPM (60 – 98 L/min).

NOTE: Exceeding 26 GPM (98 L/min) flow will over-speed the drive motor and result in motor failure.

- The machine must have an adequate lift capacity to safely maneuver the cutter at full reach on uneven ground.

Operation



WARNING



**THROWN OBJECTS OR ROTATING BLADES CAN
CAUSE SERIOUS INJURY OR DEATH**

- Clear work area of all debris, such as rope, wire, cable, or other materials that can wrap around blade carrier and blades, causing entanglement and attachment damage.
- **DO NOT** operate brush cutter in vicinity of bystanders, animals, or damageable property. Objects can be thrown more than several hundred feet.
- Keep all shields installed. Repair or replace if damaged or missing.
- Check blade carrier, blades, and mounting hardware. Replace if damaged. Never weld or modify.

3. Operation

3.4 Operating the Attachment Cont'd

Operation Cont'd

Travel Position

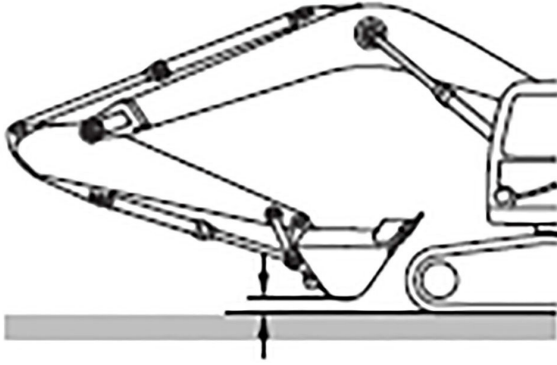

Figure 5

Position the dipperstick/arm and attachment as shown [Figure 5] and keep the attachment 16 – 20 in (40 – 50 cm) above the ground.



WARNING



Never allow riders on the brush cutter.



IMPORTANT



DO NOT operate brush cutter when excessive vibration is present. Serious damage can result. Check blade carrier, blades, and mounting hardware. Replace if damaged.

NOTE: The ground conditions and the type of brush being cut will determine the best cutting procedure and ground speed. The Mini Excavator Brush Cutter is designed to cut short or tall grass, brush, and small trees up to 6 in (152 mm) in diameter.



DANGER



ROTATING BLADES WILL CAUSE SERIOUS INJURY OR DEATH

- Never put hands, feet or objects into or under brush cutter when engine is running.
- Keep bystanders away.
- No riders.
- Stop engine before leaving the machine to service.

3. Operation

Clearing Work Area

! IMPORTANT !

- DO NOT operate in a work area that has not been cleared of foreign debris and obstacles.
- Rocks, metal, construction debris, and other objects can damage the blade carrier and blades.
- Clearly mark any objects that cannot be removed.



Initial Setup

Starting the Cutter

Install the Mini-Excavator Brush Cutter onto the machine.

Move to the operator's position, lower seat bar, start the engine and release the parking brake.

Raise the mini-excavator brush cutter approximately 6 in. (152 mm) off the ground.

With the mini-excavator engine RPM just above idle, engage the auxiliary hydraulic flow (see the mini excavator operator's manual) to the cutter head.

Slowly raise the mini-excavator engine RPM to the correct and desired cutter speed.

! CAUTION !

DO NOT exceed 3000 PSI operating pressure. Serious damage can result.

Stopping the Cutter

Position the mini-excavator brush cutter approximately 6 in. (152 mm) off the ground.

Disengage the auxiliary hydraulic flow (see the mini excavator operator's manual) to the cutter head.

3. Operation

3.4 Operating the Attachment Cont'd

Cutting Procedures



To minimize larger cut material discharging to the rear, always keep the machine between material being cut (work area) and buildings, occupied areas or roadways.

Brush Cutting

Because of flow being affected while raising the cutter, it is best to work from top down. Lift the cutter to the height needed to begin cutting.

NOTE: Always keep the angle of the blades on a plane or angle so blades are never visible from the cab.

Engage hydraulics to begin blade rotation. In some instances coming straight down is possible but most applications require swinging and then dropping slightly to swing again.

Always keep the brush cutter tilted away from the operator compartment by correcting the angle as you drop.

Grass Cutting

Set the brush cutter on the ground and then raise it up a few inches from the ground.

Engage the blades and swing. Be careful to compensate for rising or falling ground as you may need to raise or lower your boom to compensate.

Mowing can be accomplished by a swing and move machine method or swing and adjust boom method without moving the machine. Some excavators are capable of mowing while driving, some hydraulic configurations will not allow for this.

Tree Cutting



WARNING



Never allow blades to be visible from the operator position, this means you are in the direct line of discharge.

Keep the bottom of the brush cutter pointed away from the cab, raise the brush cutter to the top of tree/brush you intend to cut.

Engage blades and begin swinging side to side while slowly lowering the brush cutter through the brush.

Once into solid wood such as the base of a tree (6") the brush cutter can be slowly lowered without swinging if desired to shred finer.

NOTE: If not swinging the brush cutter side to side, avoid positioning the center of the blade carrier directly over the material being cut.

Position larger material toward the end of the blades when lowering the brush cutter directly down on trees or brush.

3. Operation

3.5 Blade Reversing Procedure

NOTE: Depending on your manufacturing date, your motor may look different, but the procedure is the same.

Step 1: Confirm Coupler Setup

New from the factory, these brush cutters are design to spin *clockwise* when properly connected to your machine. If it is spinning *counterclockwise*, then the couplers at the machine must be reversed.



WARNING



Never reverse the direction of spin by reversing the hydraulic flow at the joystick. This can cause catastrophic damage to the motor.

Step 2: Reversing Procedure

- Remove the motor hood.
- Disconnect the hydraulic hoses at the motor.
- Flip the hoses and reconnect to the motor (Item 1) [Figure 6].
- Remove the Relief Valve Cartridges and swap their positions. There is one on either side of the motor (Item 2) [Figure 6].
- Test the operation and inspect for leaks, the blades should be spinning *counterclockwise* now.
- Reinstall the motor hood.

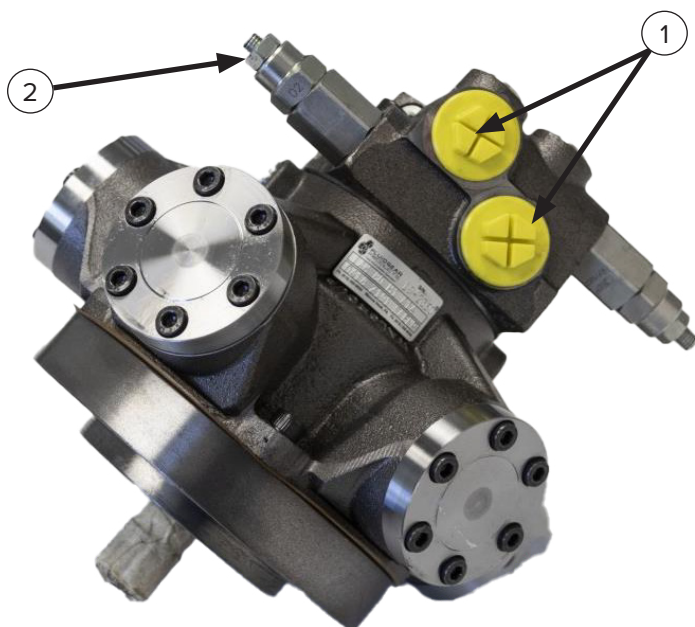

Figure 6

4. Maintenance

4.1 Service Schedule

DESCRIPTION	SERVICE PROCEDURES					
	Check	Clean	Lube	Change	Adjust	Drain
Daily Maintenance (or every 8 hours)						
Hydraulic Fittings	•					
Hydraulic Hoses	•					
Hydraulic Motor	•	•				
Blades (wear, damage, and loosening)	•					
Blade Carrier	•					
All Hardware	•					
Deck	•	•				
Weekly Maintenance (or every 40 hours)						
Blade Bolt Torque - 1440 ft/lb (1952 N•m)	•					
All Hardware	•					
Deck (cracks, bends, or damage)	•					
Monthly Maintenance						
Blades (cracks, bends, or excessive wear)	•					
Skid plates	•					
All Hardware	•					
Check Drive Oil			•			



4. Maintenance

4.2 Drive Assembly

Lubrication



Fluid such as hydraulic fluid, coolants, grease, etc. must be disposed of in an environmentally safe manner. Some regulations require that certain spills and leaks on the ground must be cleaned in a specific manner. See local, state and federal regulations for the correct disposal.

Piston Motor

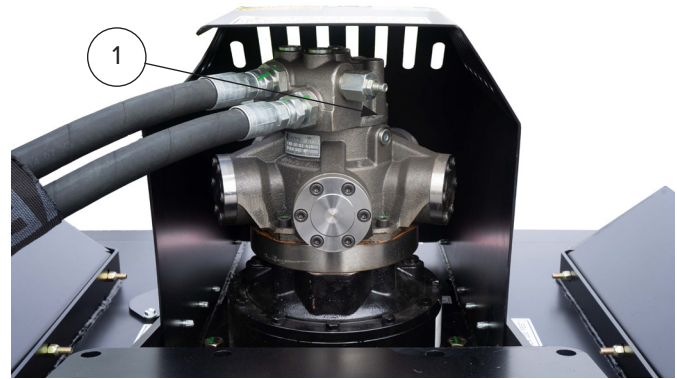

Figure 7

Oil cleanliness is critical to keeping the equipment well maintained. Change hydraulic oil and filters at required intervals to maintain the life of the brush cutter piston motor (Item 1) [Figure 7]. See the machine’s Operator’s Manual for correct service intervals.

LUBRICATION DATA

1. Type

In normal applications use an extreme pressure lubricant API-GL-5 approved. AGI recommends SAE 80W, 90 80W-90, and 85W-90 grades of lube under normal climate and operating conditions. See chart below. For severe or abnormal applications with special requirements consult lubricant manufacturer for further assistance.

2. Change Interval

Initial lubrication change after 50 hours of operation. Subsequent changes every 1000 hours or yearly whichever comes first.

3. Lube Temperature

Continuous operating temperatures of 160° F are allowable. Maximum intermittent temperature recommended is 200° F.

4. Amount of Lube

The unit should be half full when mounted horizontal. Lube levels for other mounts will vary.

5. Shaft or Spindle Up Mounting

If mounting unit vertically with shaft or spindle up, special provisions apply to ensure adequate lubrication of output bearings.

Low Temperature Gear Lube Requirement	
Viscosity Grade	Rec. Min Temperature
75W-90	-40°F (-40°C)*
80W, 80W — 90	-15°F (-26°C)*
85W, 85W — 90	10°F (-12°C)*
90	35°F (2°C)*

*Maximum temperature for Brookfield Viscosity¹ of 150,000 centerpoise (cP)² per SAE J306 MAR85

¹Brookfield Viscosity - *apparent viscosity* as determined under ASTM D 2983

²150,000 cP determined to provide sufficient low temperature lube properties

Compatible with synthetic lubricants, as long as they meet the above specified parameters.

4. Maintenance

4.3 Blade Assembly

Blade Tightening / Replacement

! **DANGER** !

AVOID SERIOUS INJURY OR DEATH

Before servicing the Brush Cutter:

- Lower the dipperstick and place the brush cutter on flat, level surface.
- Engage parking brake, stop engine, and exit the machine.
- Disconnect attachment hydraulic hoses.



Figure 8

Remove the two bolts (Item 1) [Figure 8] and cover to access blade nut.

Tightening Blade Bolts

Tighten bolts and nuts to 1440 ft/lb. (1952 N•m) of torque.

Turn blade carrier by hand to align the next blade nut with the access hole.

Repeat procedure until all blade nuts and bolts have been tightened.

Reinstall cover.

Blade Removal

Remove the nut and bolt from the blade. Remove blade.

Turn blade carrier by hand to align the next blade nut with the access hole.

Repeat procedure until all blade nuts and bolts have been removed.

NOTE: Blue Diamond® recommends replacing the bolt and nut every time the blades are changed.

Blade Installation

Align blade with the hole in the blade carrier. Push the bolt up through the blade into the blade carrier.

NOTE: Verify that blade bolt is fully seated. Thread nut on blade bolt. Tighten nut to 1440 ft/lb.(1952 N•m) of torque.

Turn blade carrier to align remaining blade mounting holes.

Repeat procedure until all blades have been installed.

Reinstall cover.

4. Maintenance

4.4 Cleaning the Attachment



DANGER



AVOID SERIOUS INJURY OR DEATH

Before servicing the Brush Cutter:

- Lower the dipperstick and tilt brush cutter fully forward (down) until the front of the brush cutter contacts the ground.
- Engage parking brake, stop engine, and exit the machine.
- Disconnect attachment hydraulic hoses.

Park the machine and attachment on a flat level surface. Lower the attachment flat on the ground.

Leave the operator's position. See "Leaving The Operator's Position" on page 10.

Disconnect attachment hydraulic hoses from the machine.

Enter the operator's position. See "Entering The Operator's Position" on page 10.

Slowly raise the machine's dipperstick, while tilting the brush cutter forward (down) until the front of the brush cutter contacts the ground.

Stop the engine, engage parking brake and leave the operator's position. See "Leaving The Operator's Position" on page 10.

Use water or air pressure to clean debris from under the brush cutter deck.

Be careful when removing any obstructions that are wrapped around blades and blade carrier.

5. Troubleshooting

PROBLEM	CAUSE	SOLUTION
Brush Cutter Vibrating	Broken or damaged blades.	Check blades and replace as needed.
	Debris under deck or on blade carrier.	Remove all debris and verify all parts rotate freely.
	Loose or missing blade bolts.	Replace missing bolts and tighten all blade bolts.
Low Pressure at Startup / Blades Turning Slow	Faulty relief valve on brush cutter or machine.	Contact your dealer or Blue Diamond® Attachments Service Department.
Hydraulic Pressure, but Blades not Rotating	Debris under deck or on blade carrier.	Remove all debris and verify all parts rotate freely.
	Against an obstacle preventing the blade carrier from rotating.	Adjust brush cutter until blades rotate freely.
	Drive is damaged or seized.	Check blades and blade carrier. Verify that blades and blade carrier rotate freely. Replace damaged or seized drive.
	Damaged motor shaft or seized motor.	Contact your dealer or Blue Diamond® Attachments Service Department.
Poor Cutting	Broken or dull blades.	Sharpen or replace blades as needed.
	Ground or swing speed too fast.	Slow down ground/swing speed.
Brush Cutter Slows or Stops When Using Other Functions	Host machine low on oil.	Fill oil reservoir.
	Host machine unable to provide enough flow.	Contact Dealer or Blue Diamond®.

6. Parts

6.1 Hydraulic Piston Motor

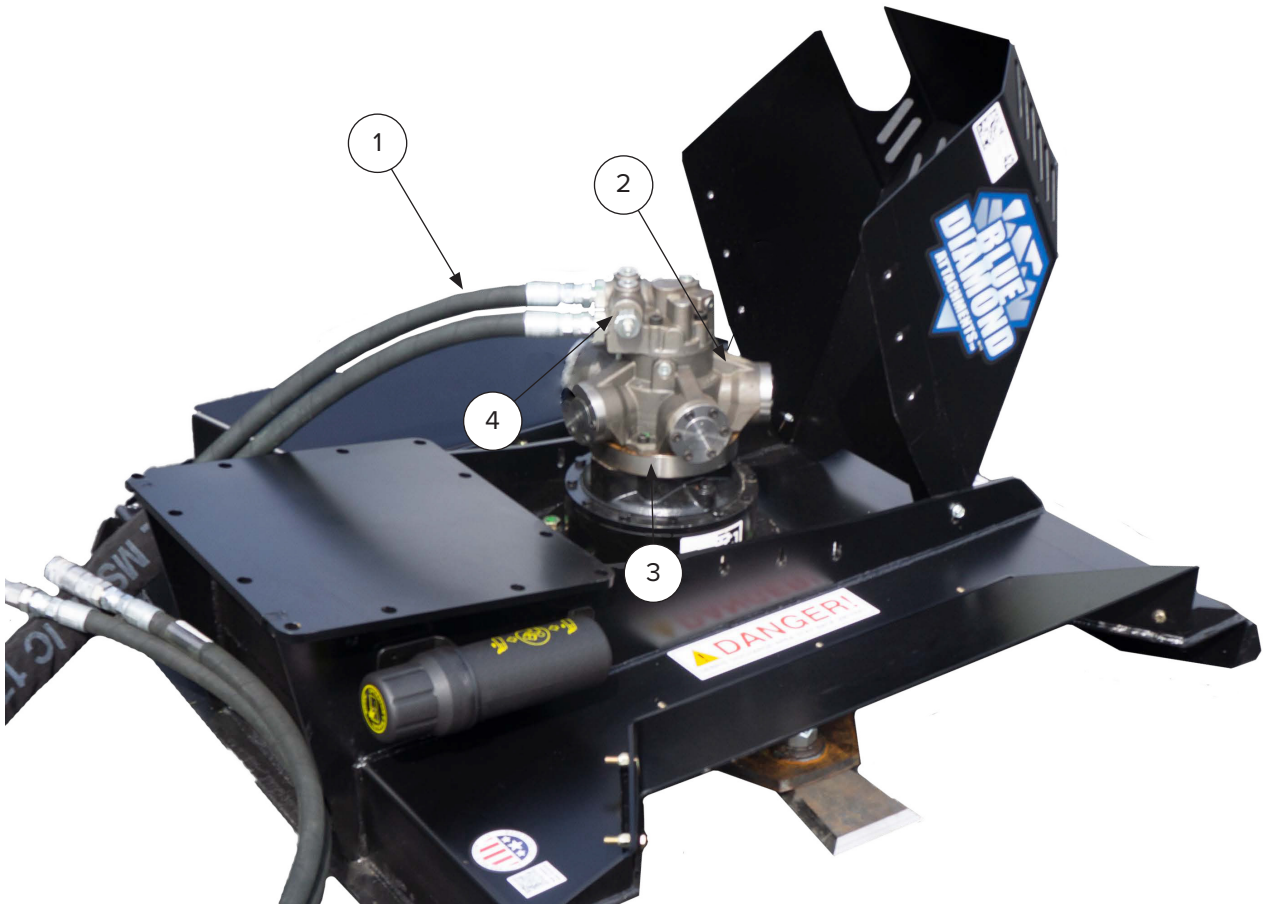

ITEM	PART NUMBER	DESCRIPTION	QTY
1	203032	Hose Set Assembly Kit	1
2	203800	Piston Motor 80cc	1
3	203810	Adapter Flange (included with motor)	1
4	203816	Relief Valve	1
NS	203814	Seal Kit for 80cc Piston Motor	1

6. Parts

6.2 Brush Cutter Deck

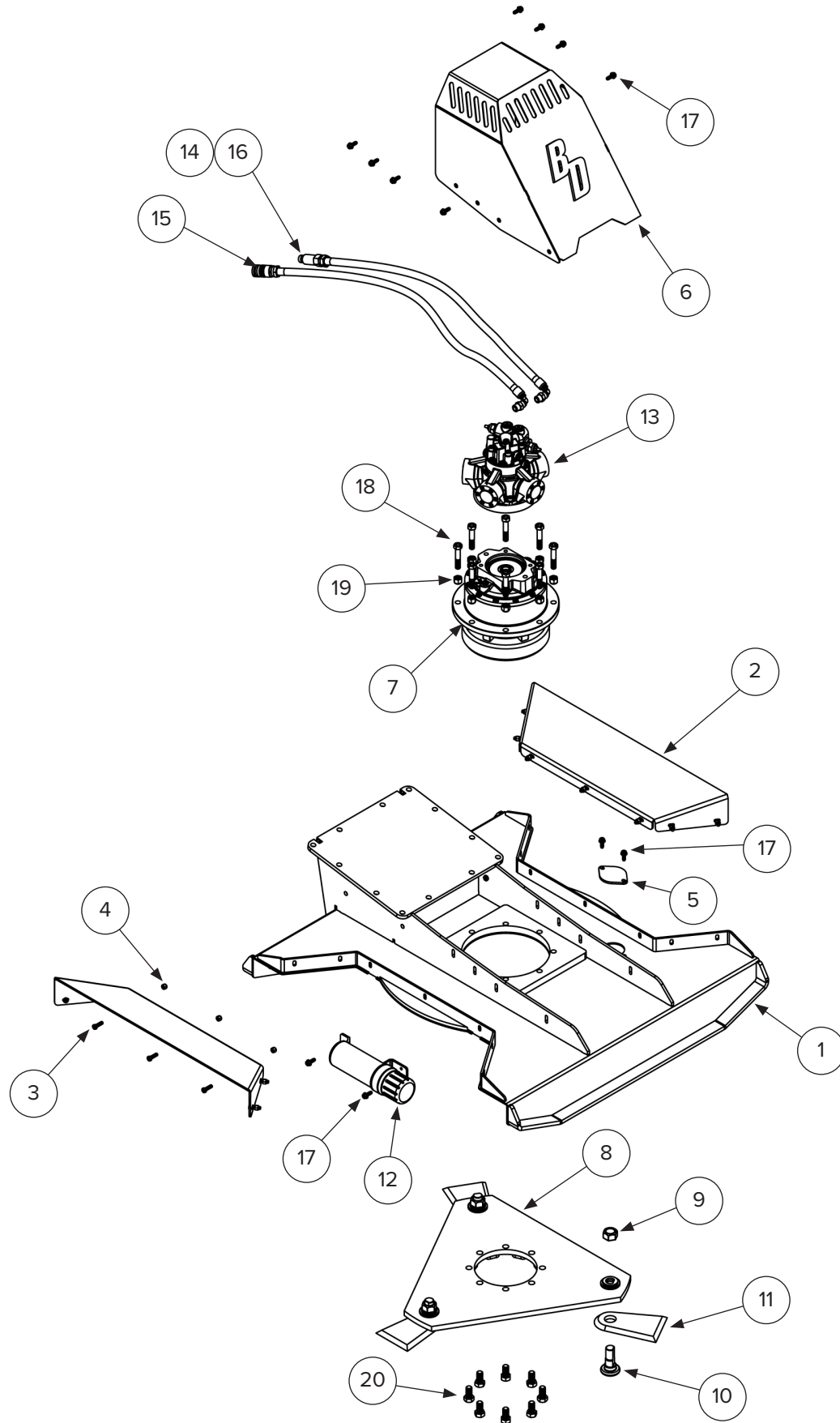

6. Parts

6.2 Brush Cutter Deck Cont'd

ITEM	PART NUMBER	DESCRIPTION	QTY
1	203851-2	Deck weldment – 42”	1
2	203855	Side deflector w/ hardware	2
3	299428	Hex bolt - grade 8 - 3/8” - 16 x 1 1/2”	14
4	299625	Locknut - grade 8 - 3/8 - 16	14
5	203008	Inspection cover	1
6	203845-2	Motor cover	1
7	203350	Direct Drive (8t2c1400f1gzx) – Auburn Gear	1
NS	PSR100A8	Direct Drive – Plan Star	1
8	203676-2	Blade carrier - 42”	1
9	203030	Blade nut	3
10	203035	Blade bolt	3
11	203670	Brush cutter blade	3
12	215402	Storage tube for manual	1
13	203800	Piston motor - 80cc	1
14	203039	Hydraulic hose kit	1
15	224011	Hydraulic - female coupler	1
16	224012	Hydraulic - male coupler	1
17	203006	Thread forming screw - 3/8-16 x 1.00	12
18	299445	Hex bolt - grade 8 - 5/8-11 x 3 1/4	8
19	299627	Lock nut - grade 8 - 5/8-11	8
20	299454	Hex bolt - grade 8 - 3/4-10 x 2	8
NS	299331	Flange to Direct Drive Bolts	4

6. Parts

6.3 Decal Identification & Location



ITEM	PART NUMBER	DESCRIPTION	QTY
1	BD-081	Warning (Front and Back)	2
2	BD-007	High Pressure Fluid Hazard	1
3	BD-087	Attention	1
4	BD-055	Danger (Both Sides)	2
5	BD-072	Warning	1
6	BD-057	Blue Diamond®	2
7	BD-082	Attention	1
8	BD-001	Read Owner's Manual	1
9	BD-090	Caution	1
10	BD-118.2	Severe Duty Series 2	2

7. Specifications

7.1 Attachment Specifications

DESCRIPTION	MINI-EXCAVATOR SEVERE DUTY SERIES 2 BRUSH CUTTER
Overall Height	23 in. (584 mm)
Overall Length	50 in. (1270 mm)
Overall Width	46 in. (1168 mm)
Cutting Height (minimum from ground)	2.5 in. (63 mm)
Cutting Width	42 in. (1067 mm)
Weight (with mounting blade)	625 lbs. (283 kg)
Blade Type	Double Edge, 5-1/2" Wide, AR400
Blade Rotation	Clockwise
Number of Blades	3
Drive System	Direct Drive
Minimum Hydraulic Flow	16 GPM (60 L/min)
Maximum Hydraulic Flow	26 GPM (98 L/min)
Maximum Relief Pressure	3000 PSI (206 bar)
Drive Lubricant (or equivalent)	Refer to page 19

7. Specifications

7.2 Torque Specifications

Standard Hardware and Lock Nuts

BOLT TYPE	SAE GRADE 5		SAE GRADE 8		LOCK NUTS			
	Nominal Size	Plated or Unplated Silver	Plated W/ ZnCr Gold	Plated or Unplated Silver	Plated W/ ZnCr Gold	Plated or Unplated Silver	Plated W/ ZnCr Gold	W/ Grade 5 Bolt
1/4	55 in / lb (6.2 N•m)	72 in / lb (8.1 N•m)	86 in / lb (9.7 N•m)	112 in / lb (12.6 N•m)	121 in / lb (13.6 N•m)	157 in / lb (17.7 N•m)	61 in / lb (6.9 N•m)	86 in / lb (9.8 N•m)
5/16	115 in / lb (13 N•m)	149 in / lb (17 N•m)	178 in / lb (20 N•m)	229 in / lb (26 N•m)	250 in / lb (28 N•m)	325 in / lb (37 N•m)	125 in / lb (14 N•m)	176 in / lb (20 N•m)
3/8	17 ft / lb (23 N•m)	22 ft / lb (30 N•m)	26 ft / lb (35 N•m)	34 ft / lb (46 N•m)	37 ft / lb (50 N•m)	48 ft / lb (65 N•m)	19 ft / lb (26 N•m)	26 ft / lb (35 N•m)
7/16	27 ft / lb (37 N•m)	35 ft / lb (47 N•m)	42 ft / lb (57 N•m)	54 ft / lb (73 N•m)	59 ft / lb (80 N•m)	77 ft / lb (104 N•m)	30 ft / lb (41 N•m)	42 ft / lb (57 N•m)
1/2	42 ft / lb (57 N•m)	54 ft / lb (73 N•m)	64 ft / lb (87 N•m)	83 ft / lb (113 N•m)	91 ft / lb (123 N•m)	117 ft / lb (159 N•m)	45 ft / lb (61 N•m)	64 ft / lb (88 N•m)
9/16	60 ft / lb (81 N•m)	77 ft / lb (104 N•m)	92 ft / lb (125 N•m)	120 ft / lb (163 N•m)	130 ft / lb (176 N•m)	169 ft / lb (229 N•m)	65 ft / lb (88 N•m)	92 ft / lb (125 N•m)
5/8	83 ft / lb (112 N•m)	107 ft / lb (145 N•m)	128 ft / lb (174 N•m)	165 ft / lb (224 N•m)	180 ft / lb (244 N•m)	233 ft / lb (316 N•m)	90 ft / lb (122 N•m)	127 ft / lb (172 N•m)
3/4	146 ft / lb (198 N•m)	189 ft / lb (256 N•m)	226 ft / lb (306 N•m)	293 ft / lb (397 N•m)	319 ft / lb (432 N•m)	413 ft / lb (560 N•m)	160 ft / lb (217 N•m)	226 ft / lb (306 N•m)
7/8	142 ft / lb (193 N•m)	183 ft / lb (248 N•m)	365 ft / lb (495 N•m)	473 ft / lb (641 N•m)	515 ft / lb (698 N•m)	667 ft / lb (904 N•m)	258 ft / lb (350 N•m)	364 ft / lb (494 N•m)
1	213 ft / lb (289 N•m)	275 ft / lb (373 N•m)	547 ft / lb (742 N•m)	708 ft / lb (960 N•m)	773 ft / lb (1048 N•m)	1000 ft / lb (1356 N•m)	386 ft / lb (523 N•m)	545 ft / lb (739 N•m)



Warranty

MANUFACTURER'S LIMITED WARRANTY

BLUE DIAMOND® ATTACHMENTS, a manufacturer of quality attachments, warrants new BLUE DIAMOND® ATTACHMENTS products and/or attachments at the time of delivery to the original purchaser, to be free from defects in material and workmanship when properly set up and operated in accordance with the recommendations set forth by BLUE DIAMOND® ATTACHMENTS, LLC.

BLUE DIAMOND® ATTACHMENTS liability for any defect with respect to accepted goods shall be limited to repairing the goods at a BLUE DIAMOND® ATTACHMENTS designated location or at an authorized dealer location, or replacing them, as BLUE DIAMOND® ATTACHMENTS shall elect. The above shall be in accordance with BLUE DIAMOND® ATTACHMENTS warranty adjustment policies. BLUE DIAMOND® ATTACHMENTS obligation shall terminate twelve (12) months for the Severe Duty Mini Series 2 Brush Cutter after the delivery of the goods to original purchaser.

This warranty shall not apply to any machine or attachment which shall have been repaired or altered outside the BLUE DIAMOND® ATTACHMENTS factory or authorized BLUE DIAMOND® ATTACHMENTS dealership or in any way so as in BLUE DIAMOND® ATTACHMENTS judgment, to affect its stability or reliability, nor which has been subject to misuse, negligence or accident beyond the company recommended machine rated capacity.

WARRANTY CLAIM

To submit a warranty claim, a claim must be filed with BLUE DIAMOND® ATTACHMENTS before work is performed. The BLUE DIAMOND® PRODUCT SUPPORT TEAM will advise repairs and applicable parts exchanges. Tampering with the failed part may void the warranty. This warranty does not include freight or delivery charges incurred when returning machinery for servicing. Dealer mileage, service calls, and pickup/delivery charges are the customers' responsibility.

EXCLUSIONS OF WARRANTY

Except as otherwise expressly stated herein, BLUE DIAMOND® ATTACHMENTS makes no representation or warranty of any kind, expressed or implied, AND MAKES NO WARRANTY OF MERCHANTABILITY IN RESPECT TO ITS MACHINERY AND/OR ATTACHMENTS ARE FIT FOR ANY PARTICULAR PURPOSE. BLUE DIAMOND® ATTACHMENTS shall not be liable for incidental or consequential damages for any breach or warranty, including but not limited to inconvenience, rental of replacement equipment, loss of profits or other commercial loss. Upon purchase, the buyer assumes all liability for all personal injury and property resulting from the handling, possession, or use of the goods by the buyer.

No agent, employee, or representative of BLUE DIAMOND® ATTACHMENTS has any authority to bind BLUE DIAMOND® ATTACHMENTS to any affirmation, representation, or warranty concerning its machinery and/or attachments except as specifically set forth herein.

This warranty policy supersedes any previous documents.

NOTE: Blue Diamond® Attachments is a trademark of BLUE DIAMOND® ATTACHMENTS



QUALITY | DEPENDABILITY | INTEGRITY

Blue Diamond® Attachments
4512 Anderson Road, Knoxville, TN 37918
888-376-7027