

Heavy Duty Mini Excavator Brush Cutter

Operation and Maintenance Manual



888-376-7027 | BlueDiamondAttachments.com

Register your
WARRANTY
within 30 days
of purchase



BD-092

Introduction: Owner Information

Thank you for your decision to purchase a Blue Diamond® Heavy Duty Mini Excavator Brush Cutter. To ensure maximum performance of your equipment, it is mandatory that you thoroughly study the Operator's manual and follow the recommendations. Proper operation and maintenance are essential to maximize equipment life and prevent personal injury.

Operate and maintain this equipment in a safe manner and in accordance with all applicable local, state, and federal codes, regulations and /or laws. Follow all on-product labeling and instructions.

Make sure that all personnel have read this Operator's Manual and thoroughly understand safe and correct operating, installation, and maintenance procedures.

Blue Diamond® is continually working to improve its products. Blue Diamond® reserves the right to make any improvements or changes as deemed practical and possible without incurring any responsibility or obligation to make any changes or additions to equipment sold previously.

Although great care has been taken to ensure the accuracy of this publication, Blue Diamond® makes no warranty or guarantee of any kind, written or expressed, implied or otherwise with regard to the information contained within this manual. Blue Diamond® assumes no responsibility for any errors that may appear in this manual and shall not be liable under any circumstances for incidental, consequential, or punitive damages in connection with, or arising from the use of this manual.

Keep this manual available for frequent reference. All new operators or owners must review the manual before using the equipment and annually thereafter. Contact your Blue Diamond® Attachments Dealer for assistance, information, or additional copies of the manual. Contact www.bluediamondattachments.com or call 888-376-7027 for a complete list of dealers in your area.

Serial Number Location:

Please record attachment information in the space provided for future reference.

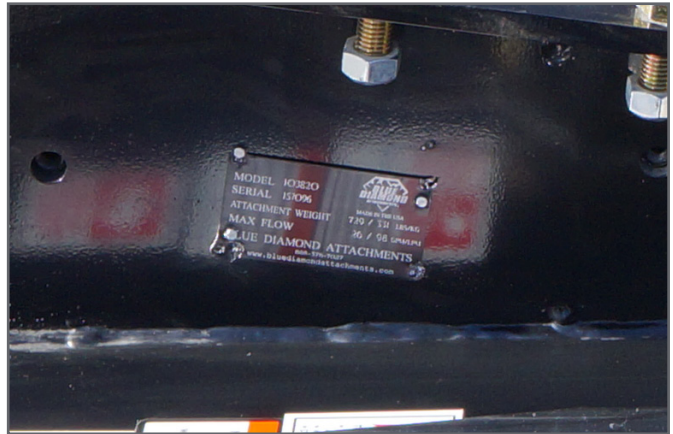

Model Number: _____

Serial Number: _____

Dealer Name: _____

Dealer Number: _____

Date of Purchase: _____

The serial number plate is located on one of the cross-members.

Always use your serial number when requesting information or when ordering parts.

NOTE: The directions left, right, front, and rear, as mentioned throughout this manual, are as viewed from the operator's position.

Revision Date: 12.02.2024

Blue Diamond® Attachments

Table of Contents

Introduction: Owner Information	2
1. Introduction.....	4
1.1 Attachment Identification	4
1.2 About This Attachment	5
1.3 Attachment Model Numbers	5
2. Safety	6
2.1 General Safety Information	6
2.2 Operators	7
2.3 Safety Guidelines	8
3. Operation	10
3.1 General Information	10
3.2 Entering and Exiting the Prime Mover	11
3.3 Attachment Installation	11
3.4 Pre-Operation	14
3.5 Operating the Attachment	16
4. Maintenance	20
4.1 Service Schedule	20
4.2 Drive Assembly	21
4.3 Before Every Use	21
4.4 Every Week	21
4.5 Every 250 Hours	21
4.6 Every Season	22
4.7 Blade Assembly	22
4.8 Hydraulic System	23
4.9 Drive Disassembly & Assembly	24
4.9 Troubleshooting	25
5. Parts.....	26
5.1 Differences Between Revisions	26
5.2 Main Breakdown – All Models	27
5.3 Blade Carrier Assembly – All Models	29
5.4 Hydraulics Breakdown – All Models	30
5.5 Direct Drive – Rev 000 / 001	32
5.6 Hose Set – All Models	33
5.7 Safety Decals	34
6. Specifications	36
6.1 Attachment Specifications	36
6.2 Torque Specifications	37
Warranty	39

1. Introduction

1.1 Attachment Identification

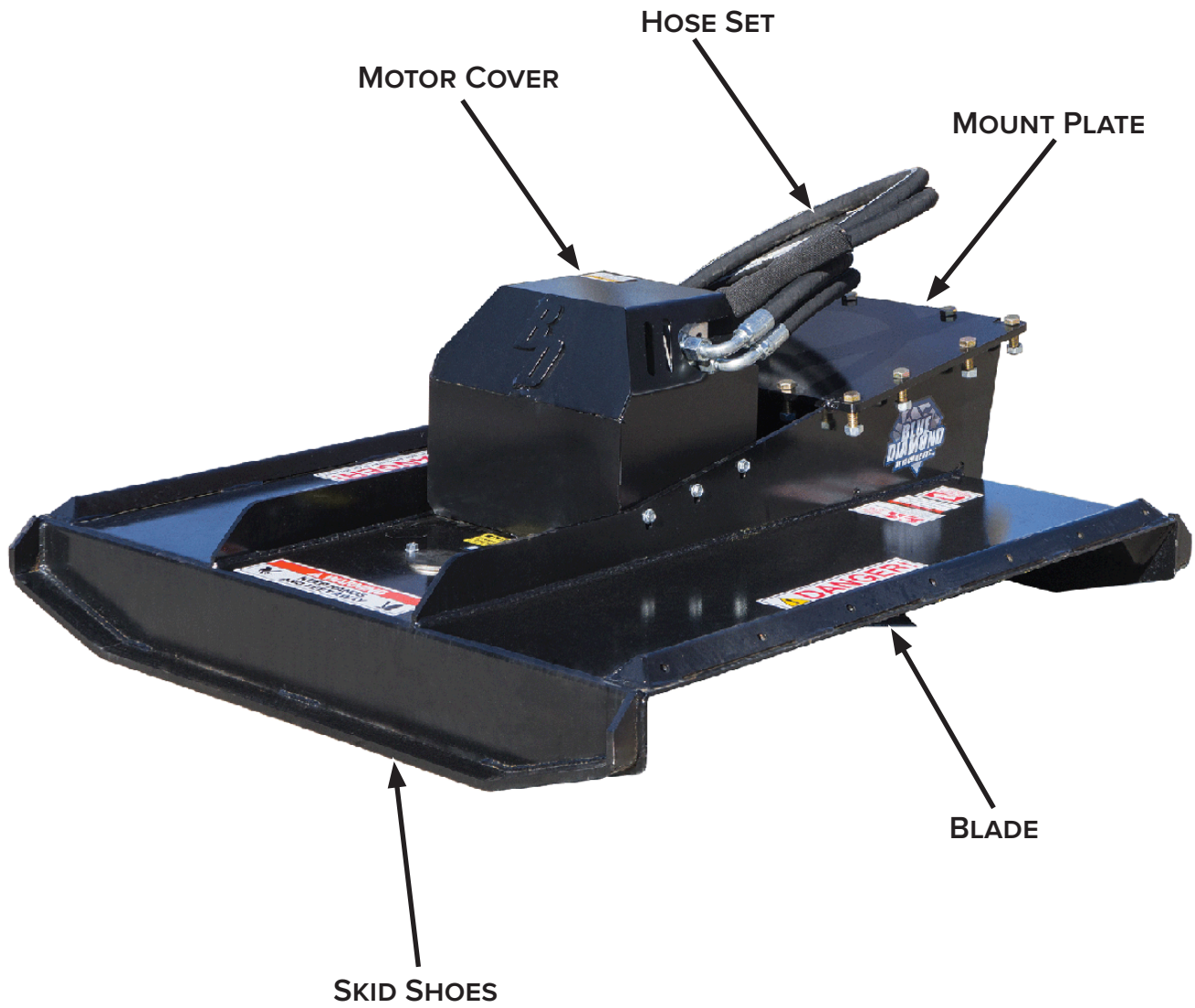

1. Introduction

1.2 About This Attachment

The Heavy Duty Mini Excavator Brush Cutter is a rotary cutter machine propelled by a single prime mover and a single operator. The direct drive system has a large flywheel that stores energy and keeps the blades cutting even in difficult conditions. These brush cutters are designed with a 3-blade system with straight AR400 double-edged blades.

The intended use of the Brush Cutter includes land clearing, landscaping, and ground maintenance. This cutter can also be utilized to clear limbs away from the edges of fields or road / path right-of-ways, pipeline access, wildfire prevention, vegetation management, invasive plant control, and wildlife restoration.

1.3 Attachment Model Numbers

MODEL NUMBER	HEAVY DUTY BRUSH CUTTER	
	WIDTH	FLOW
103600	36"	13–24 GPM
103610		29–36 GPM
103650	42"	13–24 GPM
103660		25–31 GPM
103709	50"	13–22 GPM
103712		23–28 GPM
103713		28–33 GPM
103714		34–41 GPM

2. Safety

2.1 General Safety Information



This **SAFETY ALERT SYMBOL** identifies important safety messages on the equipment and in the owner's manual. When you see this symbol, be alert to the possibility of personal injury and carefully read the message that follows.



The signal word **IMPORTANT** identifies procedures which must be followed to avoid damage to the machine.



The signal word **DANGER** on the machine and in the manuals indicates a hazardous situation which, if not avoided, will result in death or serious injury.



The signal word **WARNING** on the machine and in the manuals indicates a potentially hazardous situation which, if not avoided, could result in death or serious injury.



The signal word **CAUTION** on the machine and in the manuals indicates a potentially hazardous situation which, if not avoided, may result in minor or moderate injury. It may also be used to alert against unsafe practices.

NOTE: Notes are used to indicate important information. This information may be repeated in other areas of the manual.

Operating Safety

- Read and follow instructions in this manual and the machine's Operators Manual before operating.
- The manual must always remain with the machine. In case of loss or damage, request a new copy from your dealer or from Blue Diamond®.
- Strictly follow all rules prescribed by the safety pictograms/decals applied to the machine. Ensure that all safety pictograms/decals are legible. If pictograms/decals are worn, they must be replaced with new ones obtained from Blue Diamond®.
- Before using the machine, make sure that all safety devices are installed and in good working condition. In case of damaged or missing shields, replace them immediately.
- It is absolutely forbidden to remove or alter safety devices and/or safety precautions
- Pay maximum attention to avoid any accidental contact with rotating parts of the machine.
- If the use of the machine is required at night or in conditions of reduced visibility, use the lighting system of the prime mover and an auxiliary lighting system if required.

2. Safety

2.2 Operators

Qualified Operators

The operator is a person suited to the work and who is physically and psychologically able to withstand the demands connected with operating the equipment for its intended use. The operator must not allow anyone to approach the machine while it is working and must not allow external personnel to operate the machine or attachment.

The operator is to follow the given instructions in this manual and the machine operator's manual in order to obtain maximum performance, minimal fuel consumption, and maximum safety for him— or herself and for others.

The operator is responsible for scrupulously observing all the instructions given in this manual.



DANGER



AVOID SERIOUS INJURY OR DEATH

Operators must receive instructions before operating the machine. Untrained operators can cause serious injury or death.

For an operator to be qualified, he or she must not use drugs or alcoholic drinks which impair alertness or coordination while working. An operator who is taking prescription drugs must get medical advice to determine if he or she can safely operate a machine and the equipment. For an operator to be qualified, he or she must have read and understood the instructions of this manual, he or she must make adequate preparation for the proper use of the machine, and he or she must hold a driving license.

In case of doubt regarding the use of the machine and/or the interpretation of this manual, the operator must contact either their dealer or Blue Diamond®.

Operator Training

- Check the rules and regulations at your location. The rules may include an employer's work safety requirements. Regulations may apply to local driving requirements or use of a Slow Moving Vehicle (SMV) emblem. Regulations may identify a hazard such as a utility line.
- The new operator must start in an area without bystanders and use all the controls until he or she can operate the machine safely under all conditions of the work area.

Operator Safety

- Before starting, and during operation of the attachment, make sure there are no people or animals in the operation area; the machine can project material from the back with risks of serious injury or death.
- During operation, adjustment, maintenance, repairing, or transportation of the machine, the operator must always use appropriate Personal Protective Equipment (PPE) including but not limited to safety glasses, working gloves, dust-mask, safety helmet, and hearing protection.
- DO NOT operate the attachment or machine while wearing loose fitting clothing that can be entangled or caught in parts of the machine.
- DO NOT operate the implement when tired, not in good condition, or under the influence of alcohol or drugs.

2. Safety

2.3 Safety Guidelines

Operating Safety

- Read and follow instructions in this manual and the machine's Operator's Manual before operating.
- Under no circumstances should young children be allowed to work with this equipment.
- This equipment is dangerous to persons unfamiliar with its operation.
- Check for overhead and / or underground lines before operating equipment (if applicable).
- In addition to the design and configuration of equipment, hazard control and accident prevention are dependent upon the awareness, concern, prudence, and proper training of personnel involved in the operation, transport, maintenance, and storage of equipment.
- Check that the attachment is securely fastened to the machine.
- Make sure all the machine controls are in the NEUTRAL before starting the machine.
- Operate the equipment only from the operator's position.
- Operate the equipment according to the Operator's Manual.
- When learning to operate the equipment, do it at a slow rate in an area clear of bystanders.
- DO NOT permit personnel to be in the work area when operating the equipment.
- The equipment must be used ONLY on approved machines.
- DO NOT modify the equipment in any way. Unauthorized modification may impair the function and / or safety and could affect the life of the equipment.
- DO NOT make any adjustments or repairs on the equipment while the machine is running.
- Keep shields and guards in place. Replace if damaged.
- DO NOT operate equipment in poor visibility conditions such as fog, darkness, or any conditions that limit clear visibility less than 300 feet (100 m) in front of and to the sides of the equipment.
- When conditions make it necessary to slow ground speed, shift to a lower gear rather than reducing engine speed. The engine will maintain rated speed and keep cutter running at optimum cutting speed.
- DO NOT operate in a work area that has not been inspected for foreign debris and obstacles.
- Remove any foreign objects and clearly mark any objects that cannot be removed.
- Wear safety glasses, gloves, hearing protection, and other protective clothing when required.
- Machinery parts might have sharp edges. Wear work gloves when moving parts. Always use caution around cutter blades as they are often sharp.
- Before each operation of this attachment, check all hardware for proper location and tightness.

Machine Requirements and Capabilities

- The machine's operator's cab should be equipped with a thermoplastic polycarbonate or similar material front window, and similar protection on the sides of the operator's cab before operating the equipment.
- Keep bystanders clear of moving parts and the work area. Keep children away.
- DO NOT exceed 3200 psi (220 bar) operating pressure.
- Use caution on slopes and near banks and ditches to prevent overturn.

2. Safety

2.3 Safety Guidelines Cont'd

Fire Prevention Safety

- Flammable debris (leaves, grass, etc.) must be removed regularly. If flammable debris is allowed to accumulate, it can cause a fire hazard. Clean often to avoid this accumulation.
- The equipment's hydraulic motor compartment must be inspected every day and cleaned if necessary to prevent fire hazards and overheating.
- All fuels, most lubricants, and some coolant mixtures are flammable. Flammable fluids that are leaking or spilled onto hot surfaces or onto electrical components can cause a fire.

Transporting Safety

- Comply with state and local laws governing highway safety and movement of machinery on public roads.
- Check local laws for all highway lighting and marking requirements.
- Always yield to oncoming traffic and move to the side of the road so any following traffic may pass.
- Never allow riders on either machine or equipment.
- If transporting the equipment on a truck or trailer, make sure the equipment is properly secured to the transport vehicle.

Hydraulic System

- Check hydraulic tubes, hoses, and fittings for damage and leakage. Never use open flame or bare skin to check for leaks. Hydraulic tubes and hoses must be properly routed and have adequate support and secure clamps. Tighten or replace any parts that show leakage.
- Always clean fluid spills. Do not use gasoline or diesel fuel for cleaning parts. Use commercial nonflammable solvents.

- To avoid contamination in the attachment's hydraulics and the excavator, always clean the couplers before connecting it to the machine.

Personal Protective Equipment



Proper Work Clothes: To help ensure your safety as a designated operator wear proper work clothes including tight fitting clothes, protective gloves and shoes.



Hand Protection: To help ensure your safety as a designated operator wear protective gloves.



Protective Shoes: To help ensure your safety as a designated operator wear protective shoes.



Safety Helmet: To help ensure your safety as a designated operator wear a safety helmet.



Safety Helmet and Eye/Ear Protection: To help ensure your safety as a designated operator wear a safety helmet and eye/ear protection.

3. Operation

3.1 General Information

Pre-Operation Inspection

Before operating the Heavy Duty Mini Excavator Brush Cutter for the first time and each time thereafter, use the following list as a guideline during equipment inspection:



WARNING



AVOID SERIOUS INJURY OR DEATH

- Disengage the machine's auxiliary hydraulics, engage the machine's parking brake, stop the engine, and make sure all rotating components are completely stopped before connecting, disconnecting, adjusting, or cleaning the equipment.
 - Always keep shields and all guards in place when using the equipment.
 - Disengage the machine's auxiliary hydraulics for road travel.
 - Keep hands, feet, and clothing away from rotating parts.
- Check that all shields and guards are in place.
 - Look for loose bolts, and tighten them if necessary.
 - Check that all safety decals are in place and can be read. Replace them if necessary. Check that the blades are in good condition. Sharpen or replace if necessary.
 - Check the condition of all hydraulic components. Repair or replace if needed.



WARNING



Leaking fluids under pressure can enter the skin and cause serious injury or death. Immediate medical attention is required. Wear goggles. Use cardboard to check for leaks.

NOTE: DO NOT operate with hydraulic leaks.

- Lubricate the brush cutter in accordance to the maintenance schedule on page 20.
- Fully clean the attachment.
- Check the brush cutter mounting plate for damage. Check for loose or missing parts. Repair as needed before operating.
- Check that attachment for wear and damage each time the attachment is removed from the machine.
- Inspect the machine's mounting frame. (See the machine's Operator's Manual for inspecting the mounting frame). Replace any parts that are damaged, bent, or missing. Keep all fasteners tight. Look for cracked welds.
- Verify that the brush cutter is properly connected to the machine.

Cutter Boom Controls

The Heavy Duty Mini Excavator Brush Cutter is designed to run off the excavator's auxiliary hydraulic system and is activated and deactivated by a control in the operator's cab. Consult the machine's Operator's Manual for precise instructions on how to activate and deactivate the auxiliary circuit.

Height and tilt functions of the brush cutter are operated with the control handles in the cab. Consult the machine's Operator's Manual for precise instructions regarding these functions.

3. Operation

3.2 Entering and Exiting the Prime Mover

IMPORTANT



See the machine's Operator's Manual for detailed information on operating the mini excavator.

Entering the Operator's Position

Use the grab handles, tracks, and safety tread (on the machine) to enter the operator's position.

When in the operator's position, adjust the seat then fasten the seatbelt.

See the machine's Operator's Manual to correctly operate the machine.

Leaving the Operator's Position

WARNING

AVOID SERIOUS INJURY OR DEATH

- Always park on a flat, level surface.
- Lower the arm, and place attachment flat on the ground.
- Place all controls in NEUTRAL.
- Engage the parking brake.
- Stop the engine, and remove the key.
- Wait for all moving parts to stop.

SEE MACHINE'S OPERATOR'S MANUAL FOR ADDITIONAL INFORMATION.

Park the machine / attachment on a flat, level surface.

Place all controls in neutral, engage the park brake, stop the engine, and wait for all moving parts to stop. Leave the operator's position.

Use the grab handles, tracks, and safety tread (on the machine) to exit the operator's position.

3.3 Attachment Installation

WARNING



CRUSH HAZARD

- Before moving the machine, look in all directions and make sure no bystanders, especially small children are in the work area.
- Do not allow anyone between the machine and attachment when approaching the attachment for connecting.
- Keep fingers and hands out of pinch points when connecting and disconnecting the attachment.

Before connecting to the attachment, inspect the machine's mounting plate. (See the machine's Operator's Manual for inspecting the mounting frame).

Enter the operator's position. See "Entering the Operator's Position" on page 11.

Bracket Interchange Installation

Your Blue Diamond® Mini Excavator Brush Cutter can be used on various brands of mini excavators by changing the mounting bracket.

Order the appropriate bracket interchange from your local Blue Diamond® Attachments dealer by supplying the brand and model information of your machine.

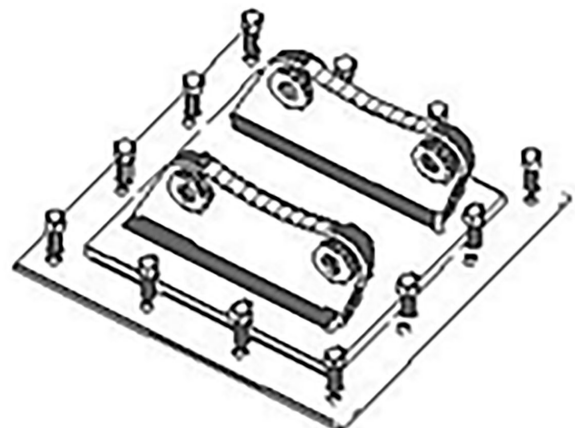

Figure 1

3. Operation

3.3 Attachment Installation Cont'd

Bracket Interchange Installation Cont'd

The bracket interchange (Figure 1, page 11) is secured to the attachment with 12 bolts. Always insert all hardware and torque them according to the value found in the Torque Specifications chart on page 37.

The bracket interchange is heavy. Use an appropriate lifting device and slings to place the bracket in position.

Loosen the hardware and position the sling straps on the hoist to position the bracket over the mounting location.

Align the holes between the bracket and deck. Insert the appropriate hardware.

Torque the hardware to the specification detailed in the Torque Specifications chart on page 37.



WARNING



AVOID SERIOUS INJURY OR DEATH

The locking pins must extend through the holes in the attachment mounting frame. Failure to secure locking pins can allow attachment to come off.

**SEE MACHINE'S OPERATOR'S MANUAL FOR
ADDITIONAL INFORMATION.**

Connecting Attachment To The Machine

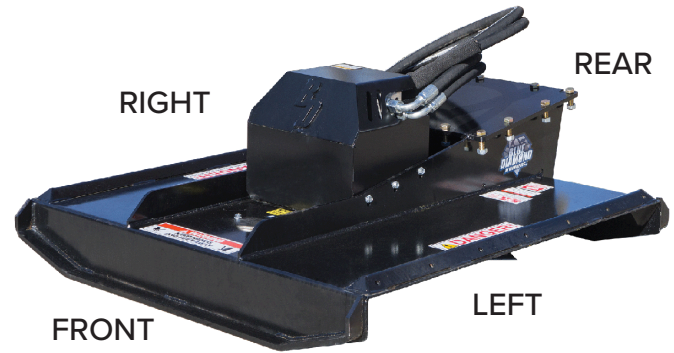

Figure 2

Position the excavator at the rear of the attachment.

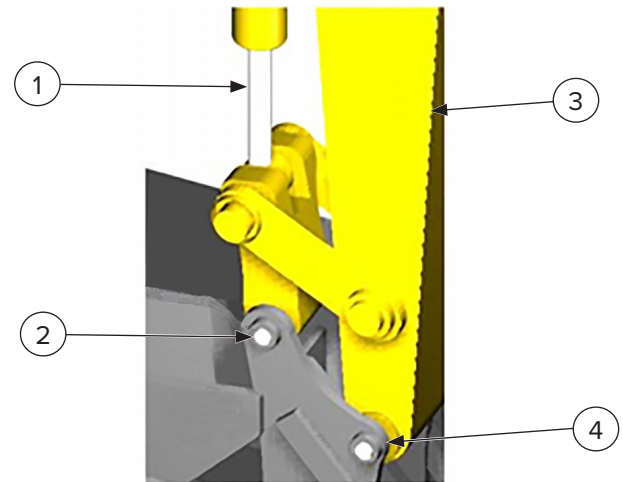

Figure 3

Extended the tool cylinder (Figure 3, Item 1) and paddle until the pin position (Item 2) is aligned.

Leave the operator's position. See "Leaving the Operator's Position" on page 11.

Install the pin through the attachment and paddle. Secure with the appropriate hardware.

Enter the operator's position. See "Entering the Operator's Position" on page 11.

Adjust the height of the excavator's dipperstick (Item 3) to align with the pin position (Item 4).

Leave the operator's position. See "Leaving the Operator's Position" on page 11.

Install the pin through the attachment and paddle. Secure with the appropriate hardware.

3. Operation

3.3 Attachment Installation Cont'd

Connecting Hydraulic Hoses



Thoroughly clean the quick couplers before making connections. Dirt can quickly damage the hydraulic system.

Remove dirt or debris from the male and female couplers. Visually inspect the couplers for corroding, cracking, damage, or excessive wear. Replace as needed.

Connect the attachment hydraulic hoses to the machine. Pull on each hose to verify full connection is made.

Disconnecting Hydraulic Hoses



AVOID SERIOUS INJURY OR DEATH

Hydraulic fluid, tubes, fittings, and quick couplers can get hot during operation. Be careful when connecting and disconnecting hydraulic hoses.



Leaking fluids under pressure can enter the skin and cause serious injury or death. Immediate medical attention is required. Wear goggles. Use cardboard to check for leaks.

Relieve auxiliary hydraulic pressure. (See the machine's Operator's Manual for correct procedure).

Disconnect attachment hydraulic hoses from the machine.

Disconnecting Attachment From the Machine

Relieve auxiliary hydraulic pressure. (See the machine's Operator's Manual for correct procedure.)

Park the machine and attachment on a flat, level surface. Lower the attachment flat on the ground.

Leave the operator's position. See "Leaving The Operator's Position" on page 11.

Disconnect attachment hydraulic hoses from the machine.

Remove hardware securing the pins, and remove the pins from the paddle and attachment.

Enter the operator's position. See "Entering The Operator's Position" on page 11.

Raise the dipperstick to clear the attachment.

Drive the machine slowly backward, away from the attachment.

3. Operation

3.4 Pre-Operation

Machine Requirements



DANGER



FLYING DEBRIS OR OBJECTS WILL CAUSE SERIOUS INJURY OR DEATH

To protect the operator from any flying debris or objects, it is important that the machine's operator's cab should be equipped with a thermoplastic polycarbonate or similar material front window and similar protection on the sides of the operator's cab before operating the Mini Excavator Brush Cutter.

The machine must have adequate lift capacity to safely maneuver the cutter at full reach on uneven ground.

The machine must be equipped with auxiliary hydraulics with a hydraulic flow described below in accordance to the model number purchased.

NOTE: Exceeding the GPM described in 6.1 Attachment Specifications on page 36 will overspeed the drive motor and result in motor failure.



CAUTION



AVOID INJURY

Make sure your machine is in good working condition. Follow the operating instructions found in the manual accompanied your excavator. Failure to do so could result in injury.



CAUTION



AVOID INJURY OR PRODUCT FAILURE

This attachment was designed for hydraulic system pressures of 3200 psi (220 bar) maximum. Pressures over this specification could result in minor or major injury and / or product failure.

Operation



WARNING



THROWN OBJECTS OR ROTATING BLADES CAN CAUSE SERIOUS INJURY OR DEATH

- Clear work area of all debris, such as rope, wire, cable or other materials that can wrap around blade carrier and blades, causing entanglement and attachment damage.
- DO NOT operate brush cutter in vicinity of bystanders, animals, or damageable property. Objects can be thrown more than several hundred feet.
- Keep all chains and shields installed. Repair or replace if damaged or missing.
- Check blade carrier, blades and mounting hardware. Replace if damaged. Never weld or modify.

Keep all shields installed. Repair or replace if damaged or missing.

Check the blade carrier, blades, and mounting hardware. Replace if damaged. Never weld or modify.

3. Operation

3.4 Pre-Operation Cont'd

Operation Cont'd

Travel Position

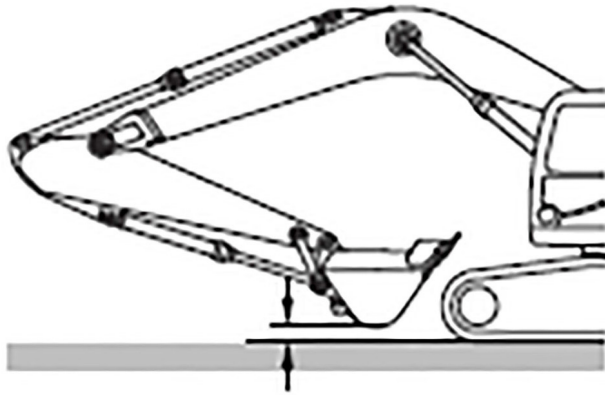

Figure 4

Position the dipperstick / arm and the attachment as shown above (Figure 4) and keep the attachment 16 – 20 in. (40 – 50 cm) above the ground.



DANGER



ROTATING BLADES WILL CAUSE SERIOUS INJURY OR DEATH

- Never put hands, feet or objects into or under brush cutter when engine is running.
- Keep bystanders away.
- No riders.
- Stop engine before leaving the machine to service.



WARNING



Never allow riders on the attachment.



IMPORTANT



DO NOT operate the brush cutter when excessive vibration is present. Serious damage can result. Check blade carrier, blades, and mounting hardware. Replace if necessary.

NOTE: The ground conditions and the type of brush being cut will determine the best cutting procedure and ground speed. The Mini Excavator Brush Cutter is designed to cut short or tall grass, brush, and small trees up to 4" in diameter.

Clearing Work Area



IMPORTANT



- DO NOT operate in a work area that has not been cleared of foreign debris and obstacles.
- Rocks, metal, construction debris, and other objects can damage the blade carrier and blades.
- Clearly mark any objects that cannot be removed.



3. Operation

3.5 Operating the Attachment

Initial Setup



Check the excavator's hydraulic oil level. If necessary, add oil before and after performing steps 1–3 below.

After starting the mini excavator, lift the attachment approximately 6" (152mm) off the ground:

1. With the excavator's engine RPMs just above idle, slowly engage the auxiliary hydraulic flow to the cutter head. Using your machine's auxiliary hydraulic flow lever / switch, activate the auxiliary flow to the brush cutter.
2. Allow the attachment to run for 30 seconds in each direction to purge the air from the system. Turn off the cutter drive, allowing it to come to a complete stop.
3. Lower the cutter attachment to the ground, and shut off the excavator's engine. Leave the operator's position (See "Leaving the Operator's Position" on page 11.)
4. Check the excavator's hydraulic oil level, and add oil necessary.
5. Inspect the cutter's hydraulic plumbing for any noticeable leaks. Correct these leaks before continuing.



Leaking fluids under pressure can enter the skin and cause serious injury or death. Immediate medical attention is required. Wear goggles. Use cardboard to check for leaks.

6. Restart the excavator. With the brush cutter raised off the ground and the engine throttle set just above idle, engage the cutter drive circuit to start the cutter. Allow the cutter to come up to speed before increasing engine speed.

Starting the Cutter



AVOID SERIOUS INJURY OR DEATH

Moving or engaging the cutter with bystanders in the area could result in death or serious injury. Before engaging cutter hydraulics, always make sure the area is clear of bystanders.

Install the Heavy Duty Mini Excavator Brush Cutter onto the machine.

Move to the operator's position, adjust the seat, fasten your seatbelt, start the engine, and release the parking brake.

Raise the attachment approximately 6" (152 mm) off the ground.

With the mini excavator engine RPM just above idle, engage the auxiliary hydraulic flow (see the machine's Operator's Manual) to the cutter head.

Slowly raise the machine's engine rpm to the correct and desired cutter speed. Use the excavator's throttle to set the speed.



If the brush cutter ever creates a vibration when increasing the speed, turn the attachment to the off position and investigate the cause. Refer to the 6.4 Troubleshooting section (page 24) of this manual.



DO NOT exceed 3200 psi (220 bar) operating pressure. Serious damage can result.

3. Operation

3.5 Operating the Attachment Cont'd

Stopping the Cutter

Position the mini excavator approximately 6" (152 mm) off the ground.

Lower the excavator's engine RPMs to an idle, and allow the cutter to slow down.

After the cutter has slowed down, turn the auxiliary hydraulics to the "off" position.

Allow the cutter to come to a stop before resting the attachment on the ground.

Wait for the cutter to come to a complete stop before leaving the operator's position (see "Leaving the Operator's Position" on page 11).

Getting Familiar with the Attachment



WARNING



AVOID SERIOUS INJURY OR DEATH

Never operate the brush cutter when bystanders are within 200 ft (60 m) of your work area. Flying debris could result in serious injury or death.



CAUTION



AVOID INJURY

Be cautious when operating on uneven ground surfaces. A machine rollover could result in injury. Always wear your seatbelt when operating this type of machinery.

Before starting the excavator's engine with the brush cutter attached, make sure you are knowledgeable and comfortable with the operation of the excavator and the brush cutter controls as outlined in the previous and following sections of this manual.



CAUTION



AVOID INJURY AND / OR PRODUCT FAILURE

DO NOT overspeed the cutter by allowing more than the maximum GPM specified in the table on page 14 to the cutter head. That table states what GPM is required to cut efficiently. Using more than the maximum GPM will overspeed the drive motor and will result in motor failure and possible serious injury.

When operating the cutter, set the excavator's throttle at a speed that will produce the required flow. Refer to the machine's Operator's Manual for additional information if necessary.

Start with learning that the cutter head looks like in a level cutting position when in the operator's position. Knowing what a level cutter head looks like will help avoid damage to the cutting blades by cutting too close to the ground.

The correct ground speed for cutting with this attachment can be monitored by sound and feel, which depends on the material density. If the excavator's engine is bogging down or if the blade carrier is turning too slow because of too much load, the ground or swing speed should be decreased.

Listen and feel for any strange vibration when working the cutter. A bad vibration felt when cutting could indicate a damaged cutting blade or material trying to be cut too fast a pace. Slow down the excavator's swing or ground speed to see if the vibration stops. If it does not, stop the cutter, turn off the machine's engine, and investigate the cause of the vibration. Refer to the 4.8 Troubleshooting (page 24) for further instructions.

Always be aware of your surroundings. While watching the cutter, also pay attention to what obstacles or terrain are in front of the cutter and prime mover's tracks. Maintain a safe swing and travel speed while cutting.

3. Operation

3.5 Operating the Attachment Cont'd

Getting Familiar with the Attachment Cont'd



WARNING



AVOID SERIOUS INJURY OR DEATH

Cutting tree branches with the cutter in an elevated position could result in serious injury or death if the excavator becomes unstable. Never raise the cutter more than a few feet off the ground when working on slopes or uneven terrain.

Cutting Procedures

Adjusting Cutter Height & Level

Use the excavator's boom and dipper to adjust the elevation of the cutter. Before and after leveling can be accomplished by using the excavator's attachment tool cylinder.



CAUTION



AVOID INJURY

Use care when operating on uneven terrain or any type of sloped surface. Keep the cutter low to the ground when working in these conditions to avoid a rollover that could result in injury.

Before Cutting



DANGER



AVOID SERIOUS INJURY OR DEATH

Never cut in close proximity to above ground electrical wires to prevent an accident that will result in death or serious injury.

Inspect the area to be cut and make sure it is free of any utilities, rocks, fence posts, fence wire, or any other objects that you do not want to cut or that would damage the cutter.

Determine a safe cutting pattern before the start of the cut. Stop the forward progress of the excavator to start the cut.

DO NOT enter into an area to be cut before the cutter rotation come up to the operating speed.

Cutting Tips



WARNING



AVOID SERIOUS INJURY OR DEATH

Never operate this attachment when bystanders are in proximity of the work area that could result in injury or death from flying debris.



IMPORTANT



Beware of fence wire and rope in the cutting area. Entangling wire or rope around the cutter's drive components could damage the lower main seal in the direct drive system, resulting in loss of oil and component failure.

Always inspect the work area before starting the cutter. Locate and mark any utilities, steel posts, rocks, or any other objects that could be damaged or would damage the cutter during operation. Never assume the work area is safe and never skip the inspection part before the start of the operation. Remove any fence material that could damage the drive components.

Operate at a safe slow-paced speed that will allow you to watch the area ahead of the cutter and the excavator.

Make sure you are operating the excavator's engine at an rpm that will produce the volume of oil flow required for this attachment.

Cutting Ground Level Vegetation

The brush cutter is capable of cutting and mulching small trees and other vegetation up to 4" (102 mm) in diameter. Learn and realize which way the tree is likely to fall, so it does not end up crashing onto the machine.

Swing the attachment from side-to-side over the vegetation to be mulched. Use a constant swing speed through the material; slow enough to adequately mulch the material to the desired size.

3. Operation

3.5 Operating the Attachment Cont'd

Cutting Procedures Cont'd

Cutting Ground Level Vegetation Cont'd



CAUTION



AVOID INJURY

DO NOT operate the cutter if you (the operator) can see the cutter blade. If the operator can see the cutter blade, the back of the cutter is raised TOO HIGH and should be lowered to avoid debris being thrown back at the operator and causing injury.

Cutting Above Ground Level Vegetation



CAUTION



AVOID INJURY

Never operate this attachment when bystanders are in proximity of the work area that could result in injury from flying debris.

Tilt and raise the front of the deck to the desired height. Allow the cutter blade to cut the vegetation. Lower the deck as you continue to mulch the material. Swing the cutter side-to-side to further minimize the size of the debris.

If the cutter speed slows down, reduce your swing / travel speed and allow the cutter to reach the proper rotating speed.

Never use your cutter to push, pull, lift, or move any type of object. DO NOT use this attachment to “push” down trees without the cutter being used.

Always allow the cutter to come up to operating speed before moving the attachment into the material you want to cut.

4. Maintenance

4.1 Service Schedule

DESCRIPTION	SERVICE PROCEDURES					
	Check	Clean	Lube	Change	Adjust	Drain
Daily Maintenance (or every 8 hours)						
Hydraulic Fittings	•					
Hydraulic Hoses	•					
Hydraulic Motor	•	•				
Blades (wear, damage, and loosening)	•					
Blade Carrier	•					
All Hardware	•					
Deck	•	•				
Chain Guard	•					
Weekly Maintenance (or every 40 hours)						
Blade Bolt Torque - 1440 ft/lb (1952.4 N•m)	•					
All Hardware	•					
Deck (cracks, bends, or damage)	•					
Chain Guard (replace missing/ broken chains)	•					
Monthly Maintenance						
Blades (cracks, bends, or excessive wear)	•					
Skid plates	•					
All Hardware	•					
250 Hour Maintenance						
Drive Assembly (5-10 pumps)				•		



4. Maintenance

4.2 Drive Assembly

Lubrication



Fluid such as hydraulic fluid, coolants, grease, etc. must be disposed of in an environmentally safe manner. Some regulations require that certain spills and leaks on the ground must be cleaned in a specific manner. See local, state, and federal regulations for the correct disposal.

Drive Housing

Apply 4 – 6 pumps of grease to the grease zerk on the drive housing.

NOTE: Grease will exit the vent hole into the bellows. This will cause excess grease to build up in the bellows.

NOTE: When the brush cutter is new, you may see a handful of grease pushed into the bellows, then it will stop. The bellows, if overfilled, may rupture. Check discharge for the presence of oil as this may signify a leaking motor.

4.3 Before Every Use

Check that all fasteners (nuts, bolts, pins, keepers) are in their right place and are tight.

Inspect and replace any worn, torn, or missing safety decals.

Investigate the location of any oil leaks and repair.

4.4 Every Week

Check the condition of the blades by raising the cutter attachment off the ground and tilt the attachment forward to the 90° position. Lower the attachment to the ground.

Inspect the cutter blades. Remove and sharpen them if necessary. Sharp cutter blades will cut more efficiently than dull blades.

4.5 Every 250 Hours

Lubricate the drive unit using Shell Gadus S3 V220C 2 grease or equivalent. Pump the grease through the zerk until excess grease escapes from the small hole on the opposite side of the housing as shown in Figure 5.

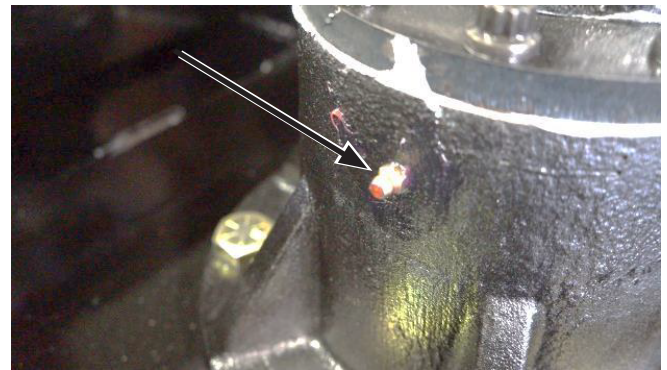

Figure 5

4. Maintenance

4.6 Every Season

Inspect the implement for any loose or worn parts that may need to be replaced prior to the next cutting season.

Visually inspect the cutting blades. Sharpen or replace them if necessary.

Clean, sand, and repaint any area that looks worn or scratched to prevent further rusting. Use a paint specially made for equipment typically found at your local hardware store or building center.

Store your implement in a shed or cover with a waterproof tarp to protect it from the elements. Store in an area not frequented by children.

4.7 Blade Assembly

Blade Removal



DANGER



AVOID SERIOUS INJURY OR DEATH

Before servicing the attachment:

- Lower the dipperstick, and place the brush cutter on a flat, level surface.
- Engage the parking brake, stop the engine, and exit the machine.
- Disconnect the attachment's hydraulic hoses.



CAUTION



AVOID INJURY

Cutter blades can be very sharp and could cause injury if mishandled. **ALWAYS** wear protective gloves and footwear.

1. Loosen the two bolts securing the blade nut access cover to the deck plate on the top right side of the deck plate. Pivot the cover to access the nut through the hole in the top of the deck.



Figure 6

2. Slowly rotate the blade carrier by hand until the blade nut is centered in the access hole as shown above in Figure 6.
3. Loosen and remove the nut with an air impact wrench, and allow the blade to drop to the floor.
4. Repeat steps 1–3 until all blade nuts and bolts have been removed.

NOTE: Blue Diamond® recommends replacing the bolt and nut every time the blades are changed.

Blade Installation

1. Align the blade with the hole in the blade carrier.
2. Insert the new bolt up through the hole into the blade carrier. Thread the nut onto the blade bolt.



IMPORTANT



Always use a new bolt and nut in every installation. Reused hardware will sometimes not retain the torque necessary to stay tight.

3. Tighten the blade hardware with an air impact wrench to 1440 ft/lb. (1952 N·m) of torque.
4. Turn the blade carrier to align the remaining blade mounting holes.
5. Repeat the procedure until all blades have been installed.
6. Reinstall the access cover, and tighten the hardware.

4. Maintenance

4.7 Blade Assembly Cont'd

Blade Inspection



IMPORTANT



Always service (sharpen or replace) the blades as a set. Never run the brush cutter with unmatched blades. **NEVER** install one used and one new blade as they may cause the cutter to be unbalanced and result in a vibration during operation and may cause harm to the other components

Sharpen the blades with the appropriate equipment, but be careful not to overheat the blade steel, causing the blade material to become brittle and prone to early failure.

Grind both blades to the similar shape and size, being careful not to create a mismatched set of blades.

4.8 Hydraulic System



CAUTION



AVOID INJURY AND / OR PRODUCT FAILURE

This attachment is designed for hydraulic system pressures of 3200 psi (220 bar) maximum. Pressures over this specification could result in injury and / or product failure.

Consult with your mini excavator dealer regarding the maximum pressure available to the attachment. Never use this attachment on a machine that would supply more than 3200 psi (220 bar) to the hydraulic motor.

4. Maintenance

4.9 Drive Disassembly & Assembly



To prevent voiding warranty coverage, contact Blue Diamond® Product Support before the disassembly of any drive compents.

Drive Disassembly

1. Support the Brush Cutter by the blade carrier.
2. Remove the motor cover.
3. Disconnect the hoses from the motor.
4. Remove the motor and flange from the direct drive.
5. Remove the top nut, star lock washer, spindle washer, and top bearing / race.
6. Lift the Brush Cutter straight up, using the excavator. This leaves behind the spindle,

blade carrier, and blades on the support. Remove the lower seal and bottom bearing.

NOTE: The bottom bearing is pressed in.

Drive Assembly

Reassemble in reverse order. See below for notes on reassembly.

- Align the tab of washer with the groove in the spindle, and slide down onto the bearing. See Figure 7, Item 1.
- Align the tab of the star lock washer with the drive in the spindle, and slide down to the spindle washer. Bend up the tabs to secure the top nut when snug. See Item 2.
- Apply red Loctite®. Hand-tighten the nut until snug, and bend up the tabs on the star lock washer. See Item 3.

NOTE: To avoid premature bearing wear, do not overtighten the nut beyond 100 ft/ lbs.

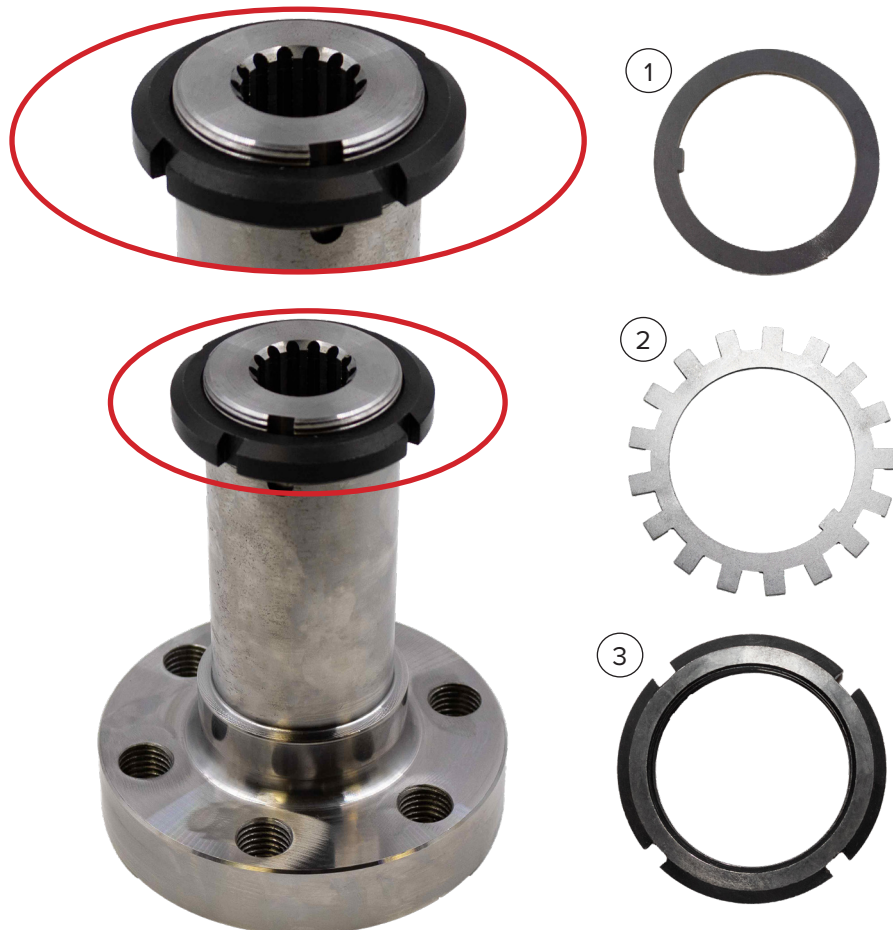

Figure 7

4. Maintenance

4.9 Troubleshooting

PROBLEM	CAUSE	SOLUTION
Cutter bogs down	Dull blades	Remove and sharpen blades.
	Ground or swing speed too fast	Slow down ground / swing speed.
	Cutter speed too slow	Raise engine RPMs or investigate other low oil flow problems.
Vibrations felt when operating	Missing, loose, damaged, or unbalanced cutter blades	Replace blades with new or re-sharpened and equally balanced blades
	Blade carrier damaged	Replace blade carrier.
	Drive housing loose on deck	Tighten and torque drive mounting bolts. Replace bolts if damaged.
	Cutting height too low for cutting in sandy or rocky soils	Raise cutter height.
Blades get dull too quickly.	Blades have contacted solid objects (rocks, steel pipes, etc.)	Clear cutting area of solid objects before hitting them or raise the cutter height to clear exposed rock surfaces.
Blades breaking	Excessive shock loads	Avoid hitting solid objects (rock, steel pipes, large tree stumps, etc.).
Hydraulic oil level goes down during operation	Leak at cutter motor or other plumbing	Investigate and repair.
	Leak in excavator hydraulic system	Investigate and repair.
Blades do not spin when flow is activated	Excavator's auxiliary system problem	Possible excessive system pressure. Contact your excavator dealer.
	Hydraulic motor failed.	Possible excessive system pressure. Contact Blue Diamond® Product Support.

5. Parts

5.1 Differences Between Revisions

Revision 000



C-flange motor

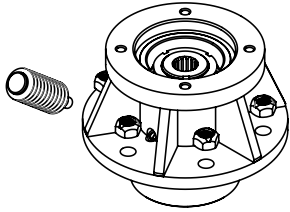

Grease-filled direct drive with bellow assembly

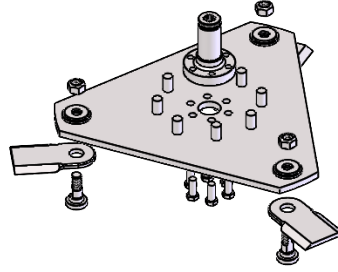

Wire protection rings and studs welded to the bottom of the deck and top of the blade carrier

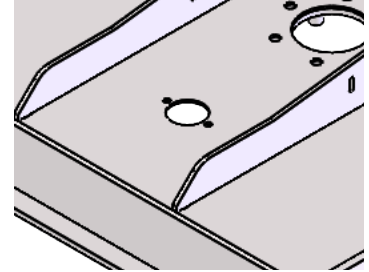

The blade bolt access cover bolt holes are perpendicular to the deck braces.

Revision 001

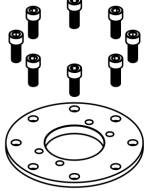
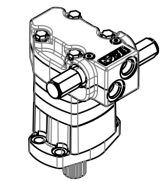

Magneto motor with flange adapter

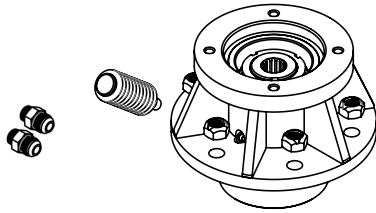

Grease-filled direct drive with bellow assembly

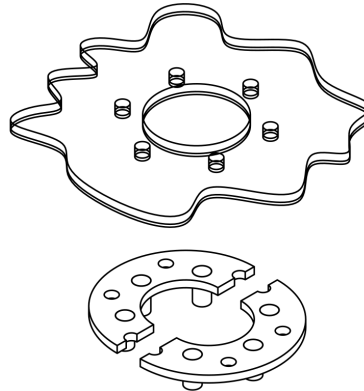

Wire protection ring and studs bolted to the bottom of the deck

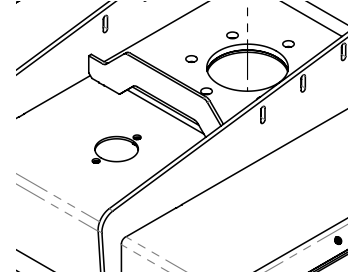

The blade bolt access cover bolt holes are parallel to the deck braces.

5. Parts

5.2 Main Breakdown – All Models

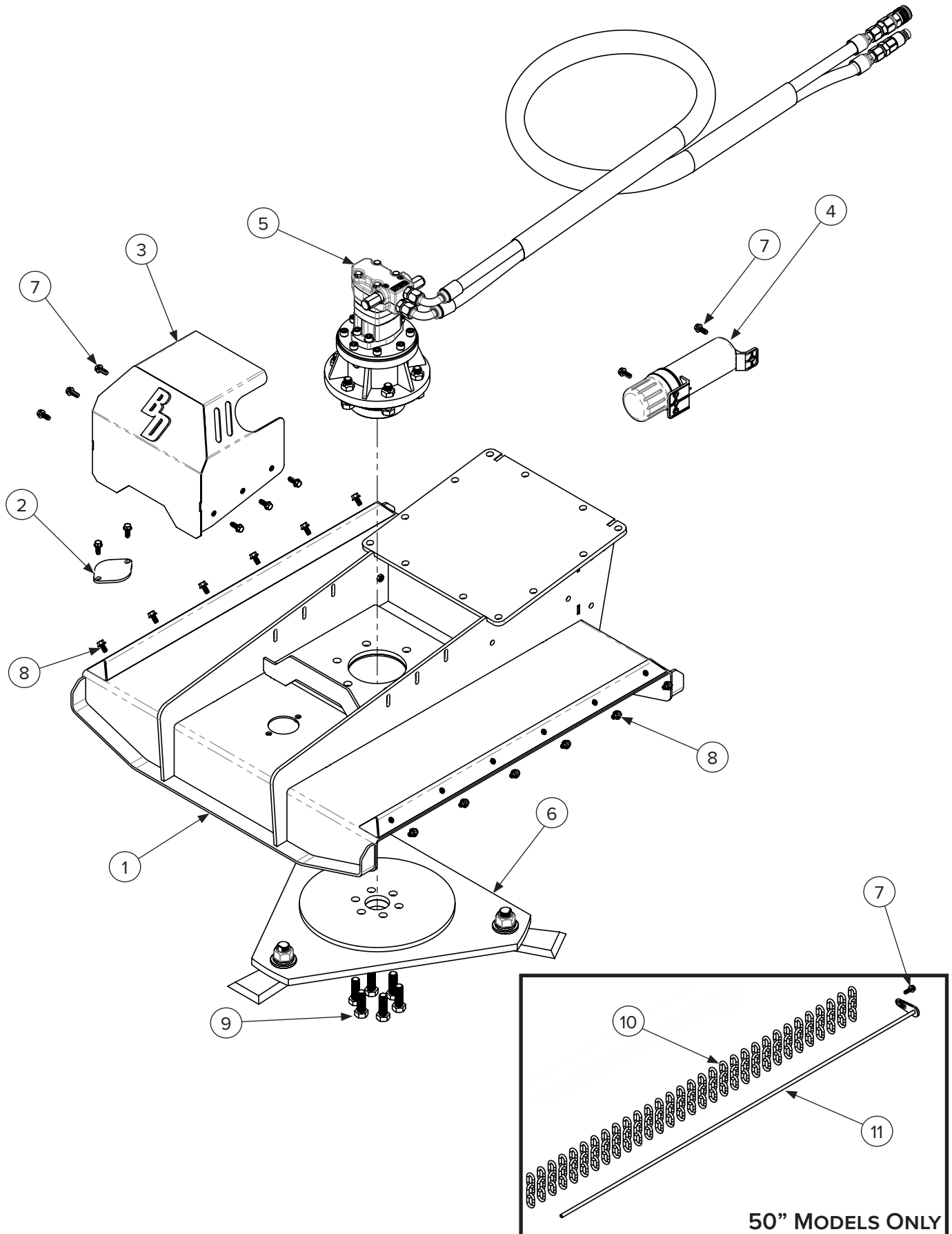

5. Parts

5.2 Main Breakdown – All Models Cont'd

Revision 001

ITEM	PART NUMBER	DESCRIPTION	QTY 36"	QTY 42"	QTY 50"
1	203601	36" Brush Cutter Deck Weldment	1	—	—
	203653	42" Brush Cutter Deck Weldment	—	1	—
	203657	50" Brush Cutter Deck Weldment	—	—	1
2	203008	Brush Cutter Inspection Cutter	1	1	1
3	203685	Motor Cover	1	1	1
4	216402	Storage Tube for Manual	1	1	1
5	See pages 29 & 30	Hydraulics	—	—	—
6	See page 28	Blade Carrier Assembly	1	1	1
7	203006	Thread Forming Screw — 3/8–16 x 1	10	10	12
8	201099	3/8–16 x 3/4" Long, Serrated–Flange Hex Head Bolt	12	14	—
9	299465	3/4–10 x 2 1/4" Hex Head Grade 8 Bolt	6	6	6
10	203600	3–Link Discharge Chain	—	—	62
11	203695	50" Chain Retainer Bar	—	—	2

Revision 000

ITEM	PART NUMBER	DESCRIPTION	QTY 36"	QTY 42"	QTY 50"
1	Contact Blue Diamond® Product Support	Brush Cutter Deck Weldment	1	1	1
2	203008	Blade Bolt Inspection Cover	1	1	1
3	203685	Motor Cover	1	1	1
4	216402	Storage Tube for Manual	1	1	1
5	See pages 29 & 30	Hydraulics	—	—	—
6	See page 28	Blade Carrier Assembly	1	1	1
7	203006	Thread Forming Screw — 3/8–16 x 1	10	10	12
9	299454	3/4 – 10 x 2" Bolt	6	6	6
10	203600	3–Link Discharge Chain	—	—	62
11	203695	50" Chain Retainer Bar	—	—	2

5. Parts

5.3 Blade Carrier Assembly – All Models

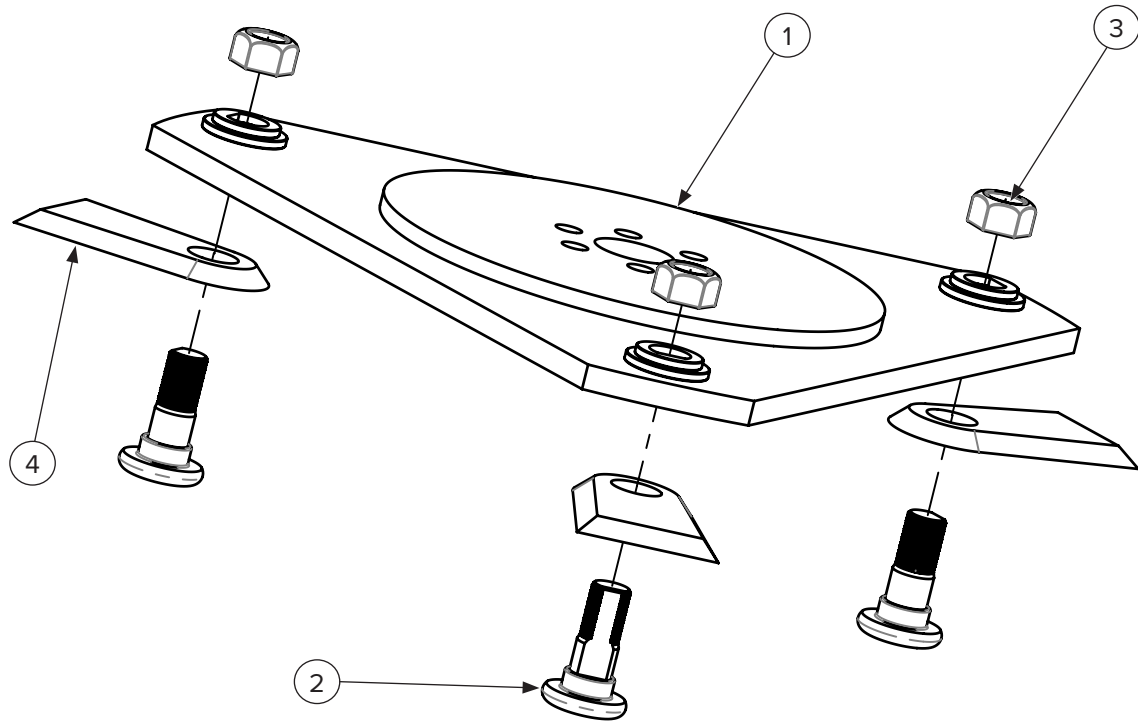

Revision 001

ITEM	PART NUMBER	DESCRIPTION	QTY
1	203641	36" Blade Carrier Weldment	1
	203674	42" Blade Carrier Weldment	
	203679	50" Blade Carrier Weldment	
2	203620	36" Blade	3
	203670	42" Blade	
	203720	50" Blade	
3	203030	Blade Nut	3
4	203035	Brush Cutter Blade Pivot Bolt	3

Revision 000

ITEM	PART NUMBER	DESCRIPTION	QTY
1	203627	36" Blade Carrier	1
	203678	42" Blade Carrier	
	203723	50" Blade Carrier	
2	203620	36" Blade	3
	203670	42" Blade	
	203720	50" Blade	
3	203030	Blade Nut	3
4	203035	Brush Cutter Blade Pivot Bolt	3

5. Parts

5.4 Hydraulics Breakdown – All Models

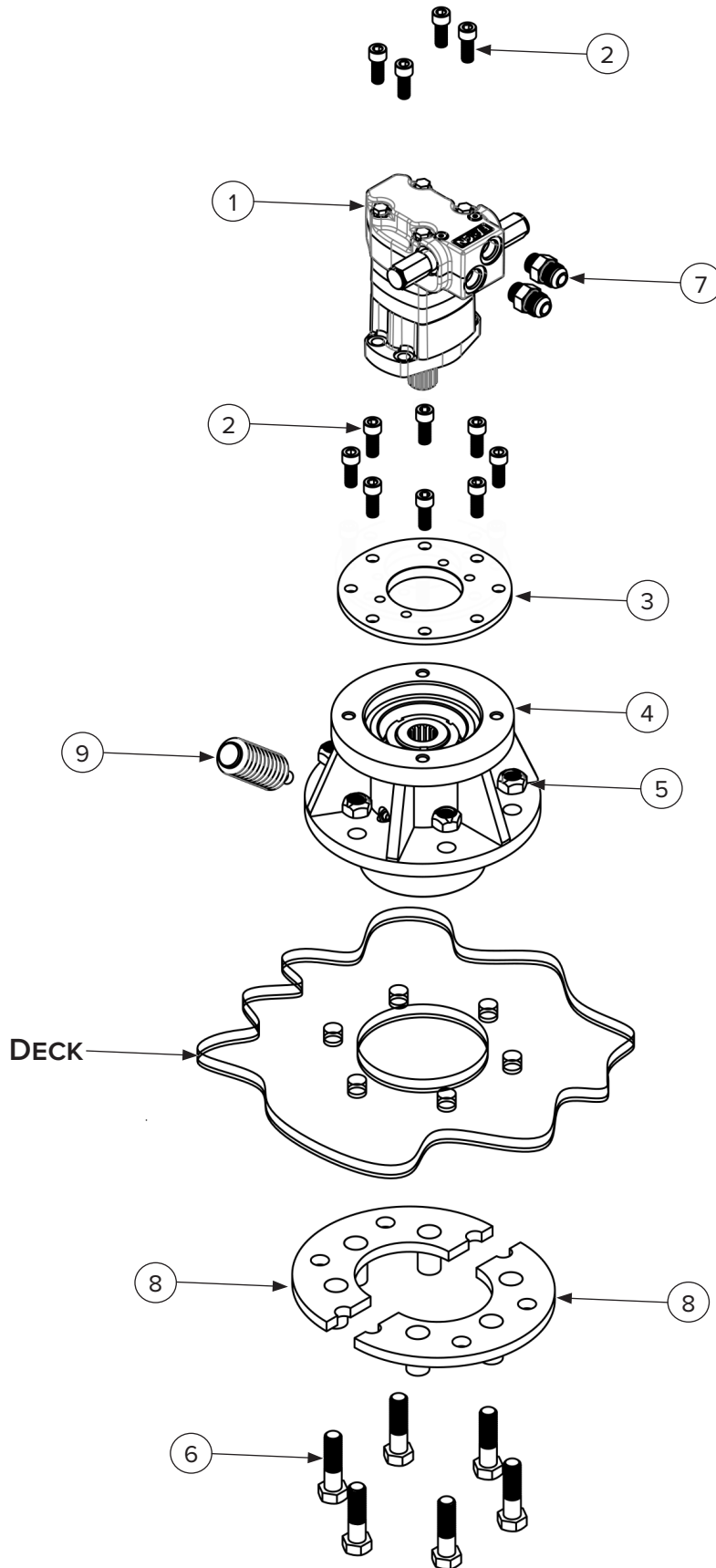

5. Parts

5.4 Hydraulics Breakdown – All Models Cont'd

Revision 001

ITEM	PART NUMBER	DESCRIPTION	QTY
1	203790	Hydraulic Motor – 80cc	1
	203797	Hydraulic Motor – 100cc	
2	299354	1/2–13 x 1.25" SHCS	12
3	203796	Adapter Plate – Motor to Drive	1
4	203629	Direct Drive Bearing Housing	1
5	299657	Stover Nut 3/4"	6
6	299489	3/4–10 x 2.75 Hex Head Screw Grade 8	6
7	295010-M12JIC-M10ORB	Hydraulic Straight Fitting Male #12 JIC x Male #10 ORB	2
8	203602	Wire Protection Ring – Half	1
9	203109	Grease Bellow Assembly	1

Revision 000

ITEM	PART NUMBER	DESCRIPTION	QTY
1	203760	Hydraulic Motor – 80cc	1
	203763	Hydraulic Motor – 100cc	
	203765	Hydraulic Motor – 125cc (50" Only)	
	203768	Hydraulic Motor – 160cc (50" Only)	
2	299433	Motor Bolt	4
NS	203775	Motor to Drive Gasket	1
4	203629	Direct Drive Assembly	1
5	299657	Stover Nut 3/4"	6
6	299466	3/4" x 2" Hex Head Bolt	6
7	295010-M12JIC-M12ORB	Hydraulic Straight Fitting Male #12 JIC x Male #12 ORB	2
9	203109	Grease Bellow Assembly	1

5. Parts

5.5 Direct Drive – Rev 000 / 001

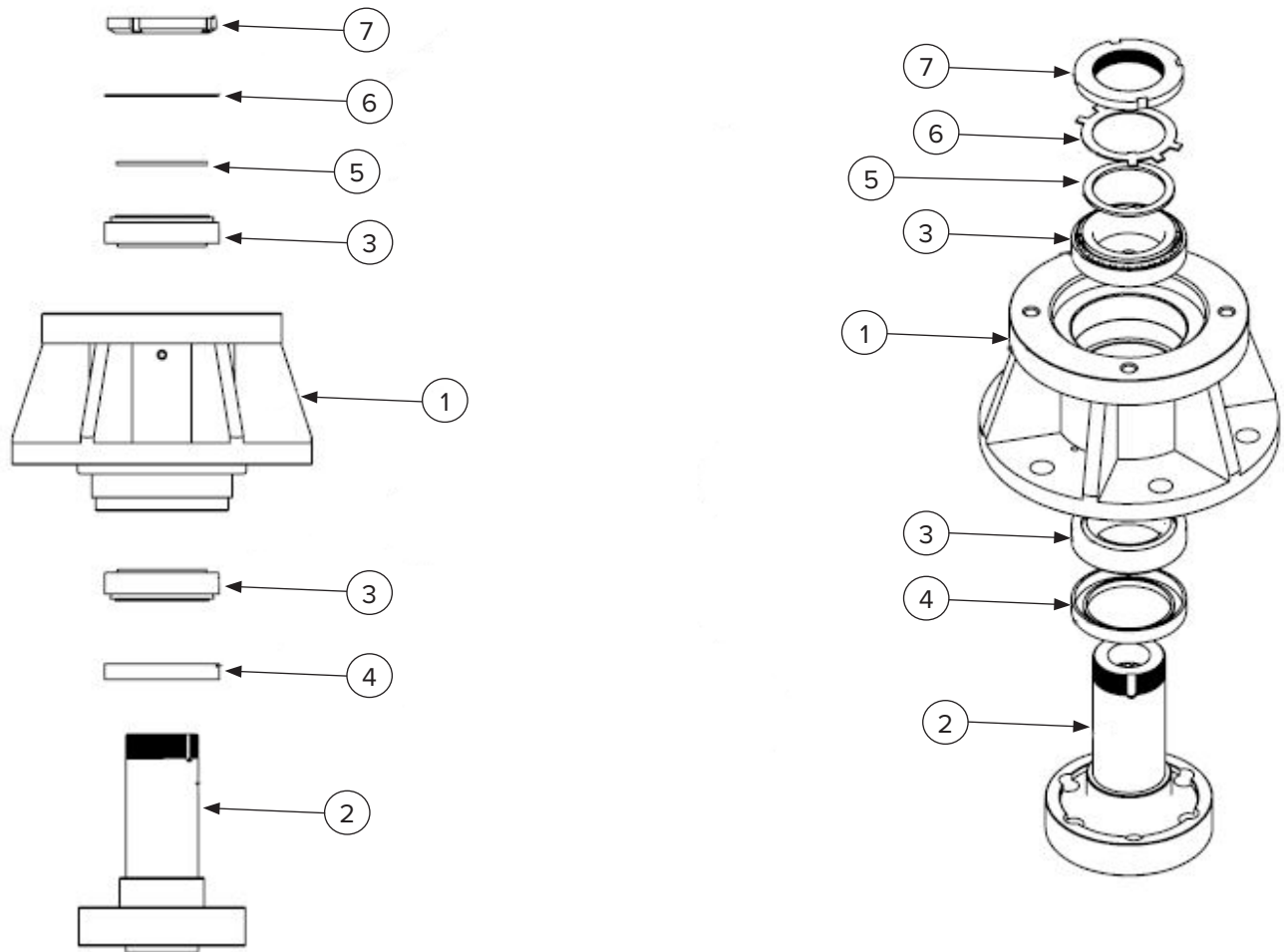

ITEM	PART NUMBER	DESCRIPTION	QTY
1-7	203629	Complete Housing Assembly	1
1	203630	Mini Spindle Housing	1
2	203632	Mini Spindle	1
3	203635	Bearing	2
4	203638	Seal	1
5	203640	Washer	1
6	203642	Lock Washer	1
7	203645	Nut	1
NS	203639	Seal Retaining Snap Ring	1



To prevent voiding warranty coverage, contact Blue Diamond® Product Support before the disassembly of any drive compents.

5. Parts

5.6 Hose Set – All Models

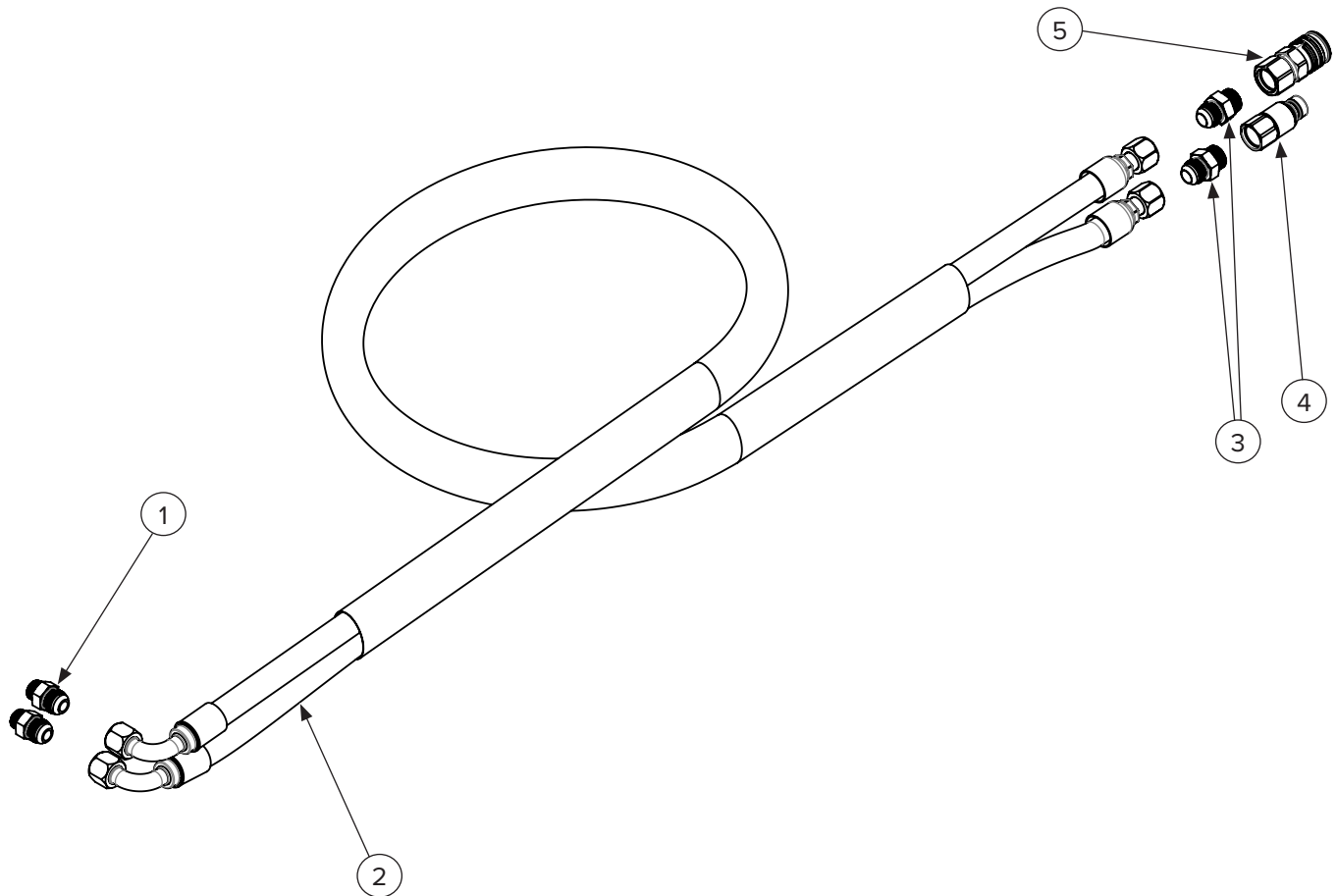

Revision 001

ITEM	PART NUMBER	DESCRIPTION	QTY
1	295010-M12JIC-M10ORB	Hydraulic Straight Fitting Male #12 JIC x Male #10 ORB	2
2	203032	Hose Set	1
3	295010-M12JIC-M12ORB	Hydraulic Straight Fitting Male #12 JIC x Male #12 Oring Boss	2
4	224012	Coupler, Male Flat Face Style, 1/2" Body, 3/4" Oring #12	1
5	224011	Coupler, Female Flat Face Style, 1/2" Body, 3/4" Oring #12	1

Revision 000

ITEM	PART NUMBER	DESCRIPTION	QTY
1	295010-M12JIC-M12ORB	Hydraulic Straight Fitting Male #12 JIC x Male #12 Oring Boss	2
2	203032	Hose Set	1
3	295010-M12JIC-M12ORB	Hydraulic Straight Fitting Male #12 JIC x Male #12 Oring Boss	2
4	224012	Coupler, Male Flat Face Style, 1/2" Body, 3/4" Oring #12	1
5	224011	Coupler, Female Flat Face Style, 1/2" Body, 3/4" Oring #12	1

5. Parts

5.7 Safety Decals

1



10

2



3



4



5



6



7



8



9



11

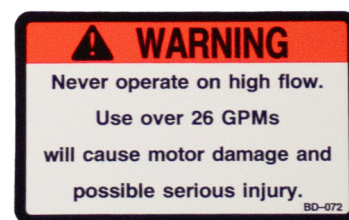

5. Parts

5.7 Safety Decals Cont'd

ITEM	PART NUMBER	DESCRIPTION	QTY
1	BD-060	Decal, Blue Diamond Attachments 2.4375" x 3.375"	2
2	BD-092	Decal, Warranty Registration QR Code 1.5" x 2.0"	1
3	BD-007	Decal, High Pressure Fluid Hazard 3.0" x 4.75"	1
4	BD-087	Decal, Attention Grease Drive Every 250 Hours of Use	1
5	BD-119	Decal, Attention Clean Motor Area Daily to Prevent Overheating or Possible Fire	1
6	BD-001	Decal, Read Owner's Manual 3.0" x 3.0"	1
7	BD-081	Decal, Warning Keep Hands and Feet Away 3.0" x 12.0"	1
8	BD-055	Decal, Danger Debris Discharge Area Stay Back 200 Feet 3.0" x 11.9062"	2
9	BD-053	Decal, Danger Do Not Operate Without Cab and Glass Guard 3.0" x 8.0"	1
10	BD-113	Decal, Blue Diamond Attachments Diamond Shape 5.0" x 6.35"	2
11	BD-072	Decal, Warning Use Over 26 GPMs 2.5" x 4.0"	1

6. Specifications

6.1 Attachment Specifications

DESCRIPTION	36"	42"	50"
Cutting Width	36" (914 mm)	42" (1067 mm)	50" (1270 mm)
Deck Thickness	3/16"		1/4"
Number of Blades	3		
Blade Design	Double-Edged		
Drive System Type	Direct Drive		
Rotation	Bi-Directional		
Weight	551 lbs	630 lbs	939 lbs
Maximum Relief Pressure	3200 psi (220 bar)		
Drive Lubricant	Shell Gadus S3 V220C 2 Grease		
SPECIAL TORQUE VALUES			
Blade Nut	1440 ft/lbs (1952 N•m)		

MODEL NUMBER	WIDTH	MOTOR SIZE	FLOW
103600	36"	80cc	13–24 GPM
103610		100cc	29–36 GPM
103650	42"	80cc	13–24 GPM
103660		100cc	25–31 GPM
103709	50"	80cc	13–22 GPM
103712		100cc	23–28 GPM
103713		125cc	28–33 GPM
103714		160cc	34–41 GPM

6. Specifications

6.2 Torque Specifications

Standard Hardware and Lock Nuts

BOLT TYPE	SAE GRADE 5		SAE GRADE 8		LOCK NUTS			
	Nominal Size	Plated or Unplated Silver	Plated W/ ZnCr Gold	Plated or Unplated Silver	Plated W/ ZnCr Gold	Plated or Unplated Silver	Plated W/ ZnCr Gold	W/ Grade 5 Bolt
1/4	55 in / lb (6.2 N•m)	72 in / lb (8.1 N•m)	86 in / lb (9.7 N•m)	112 in / lb (12.6 N•m)	121 in / lb (13.6 N•m)	157 in / lb (17.7 N•m)	61 in / lb (6.9 N•m)	86 in / lb (9.8 N•m)
5/16	115 in / lb (13 N•m)	149 in / lb (17 N•m)	178 in / lb (20 N•m)	229 in / lb (26 N•m)	250 in / lb (28 N•m)	325 in / lb (37 N•m)	125 in / lb (14 N•m)	176 in / lb (20 N•m)
3/8	17 ft / lb (23 N•m)	22 ft / lb (30 N•m)	26 ft / lb (35 N•m)	34 ft / lb (46 N•m)	37 ft / lb (50 N•m)	48 ft / lb (65 N•m)	19 ft / lb (26 N•m)	26 ft / lb (35 N•m)
7/16	27 ft / lb (37 N•m)	35 ft / lb (47 N•m)	42 ft / lb (57 N•m)	54 ft / lb (73 N•m)	59 ft / lb (80 N•m)	77 ft / lb (104 N•m)	30 ft / lb (41 N•m)	42 ft / lb (57 N•m)
1/2	42 ft / lb (57 N•m)	54 ft / lb (73 N•m)	64 ft / lb (87 N•m)	83 ft / lb (113 N•m)	91 ft / lb (123 N•m)	117 ft / lb (159 N•m)	45 ft / lb (61 N•m)	64 ft / lb (88 N•m)
9/16	60 ft / lb (81 N•m)	77 ft / lb (104 N•m)	92 ft / lb (125 N•m)	120 ft / lb (163 N•m)	130 ft / lb (176 N•m)	169 ft / lb (229 N•m)	65 ft / lb (88 N•m)	92 ft / lb (125 N•m)
5/8	83 ft / lb (112 N•m)	107 ft / lb (145 N•m)	128 ft / lb (174 N•m)	165 ft / lb (224 N•m)	180 ft / lb (244 N•m)	233 ft / lb (316 N•m)	90 ft / lb (122 N•m)	127 ft / lb (172 N•m)
3/4	146 ft / lb (198 N•m)	189 ft / lb (256 N•m)	226 ft / lb (306 N•m)	293 ft / lb (397 N•m)	319 ft / lb (432 N•m)	413 ft / lb (560 N•m)	160 ft / lb (217 N•m)	226 ft / lb (306 N•m)
7/8	142 ft / lb (193 N•m)	183 ft / lb (248 N•m)	365 ft / lb (495 N•m)	473 ft / lb (641 N•m)	515 ft / lb (698 N•m)	667 ft / lb (904 N•m)	258 ft / lb (350 N•m)	364 ft / lb (494 N•m)
1	213 ft / lb (289 N•m)	275 ft / lb (373 N•m)	547 ft / lb (742 N•m)	708 ft / lb (960 N•m)	773 ft / lb (1048 N•m)	1000 ft / lb (1356 N•m)	386 ft / lb (523 N•m)	545 ft / lb (739 N•m)

**This page intentionally
left blank**



Warranty

MANUFACTURER'S LIMITED WARRANTY

BLUE DIAMOND® ATTACHMENTS, a manufacturer of quality attachments, warrants new BLUE DIAMOND® ATTACHMENTS products and/or attachments at the time of delivery to the original purchaser, to be free from defects in material and workmanship when properly set up and operated in accordance with the recommendations set forth by BLUE DIAMOND® ATTACHMENTS, LLC.

BLUE DIAMOND® ATTACHMENTS liability for any defect with respect to accepted goods shall be limited to repairing the goods at a BLUE DIAMOND® ATTACHMENTS designated location or at an authorized dealer location, or replacing them, as BLUE DIAMOND® ATTACHMENTS shall elect. The above shall be in accordance with BLUE DIAMOND® ATTACHMENTS warranty adjustment policies. BLUE DIAMOND® ATTACHMENTS obligation shall terminate twelve (12) months for the Heavy Duty Mini Excavator Brush Cutter after the delivery of the goods to original purchaser.

This warranty shall not apply to any machine or attachment which shall have been repaired or altered outside the BLUE DIAMOND® ATTACHMENTS factory or authorized BLUE DIAMOND® ATTACHMENTS dealership or in any way so as in BLUE DIAMOND® ATTACHMENTS judgment, to affect its stability or reliability, nor which has been subject to misuse, negligence or accident beyond the company recommended machine rated capacity.

WARRANTY CLAIM

To submit a warranty claim, a claim must be filed with BLUE DIAMOND® ATTACHMENTS before work is performed. The BLUE DIAMOND® PRODUCT SUPPORT TEAM will advise repairs and applicable parts exchanges. Tampering with the failed part may void the warranty. This warranty does not include freight or delivery charges incurred when returning machinery for servicing. Dealer mileage, service calls, and pickup/delivery charges are the customers' responsibility.

EXCLUSIONS OF WARRANTY

Except as otherwise expressly stated herein, BLUE DIAMOND® ATTACHMENTS makes no representation or warranty of any kind, expressed or implied, AND MAKES NO WARRANTY OF MERCHANTABILITY IN RESPECT TO ITS MACHINERY AND/OR ATTACHMENTS ARE FIT FOR ANY PARTICULAR PURPOSE. BLUE DIAMOND® ATTACHMENTS shall not be liable for incidental or consequential damages for any breach or warranty, including but not limited to inconvenience, rental of replacement equipment, loss of profits or other commercial loss. Upon purchase, the buyer assumes all liability for all personal injury and property resulting from the handling, possession, or use of the goods by the buyer.

No agent, employee, or representative of BLUE DIAMOND® ATTACHMENTS has any authority to bind BLUE DIAMOND® ATTACHMENTS to any affirmation, representation, or warranty concerning its machinery and/or attachments except as specifically set forth herein.

This warranty policy supersedes any previous documents. Please see bluediamondattachments.com/warranty-policies for the most up to date warranty information.

NOTE: Blue Diamond® Attachments is a trademark of BLUE DIAMOND® ATTACHMENTS



QUALITY | DEPENDABILITY | INTEGRITY

Blue Diamond® Attachments
4512 Anderson Road, Knoxville, TN 37918
888-376-7027