

# Severe Duty Series 2 Angle Broom

Operation and Maintenance Manual

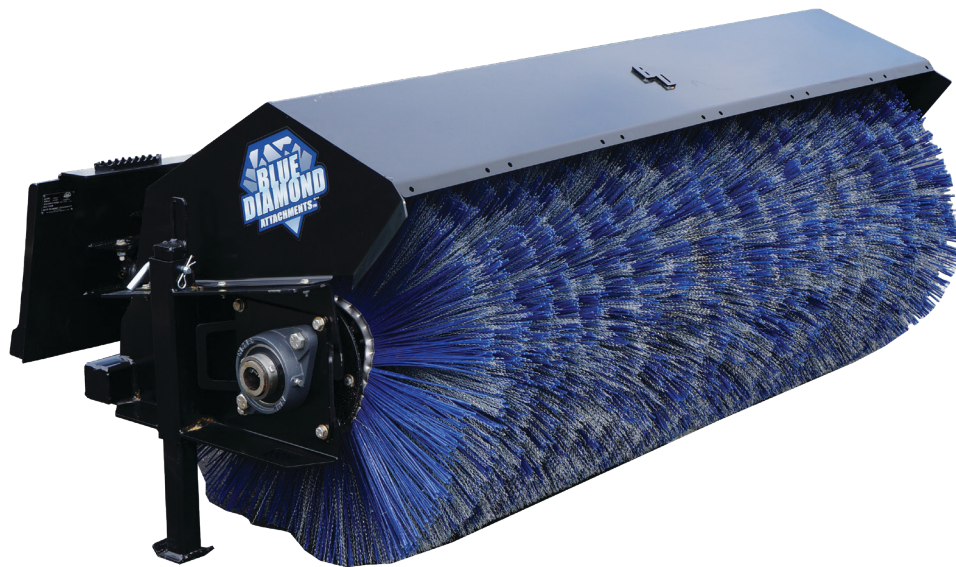

Register your  
**WARRANTY**  
within 30 days  
of purchase



888-376-7027 | [BlueDiamondAttachments.com](http://BlueDiamondAttachments.com)



BD-092

# Introduction: Owner Information

Thank you for your decision to purchase a Blue Diamond® Severe Duty Series 2 Angle Broom. To ensure maximum performance of your equipment, it is mandatory that you thoroughly study the Operator's manual and follow the recommendations. Proper operation and maintenance are essential to maximize equipment life and prevent personal injury.

Operate and maintain this equipment in a safe manner and in accordance with all applicable local, state, and federal codes, regulations and /or laws. Follow all on-product labeling and instructions.

Make sure that all personnel have read this Operator's Manual and thoroughly understand safe and correct operating, installation and maintenance procedures.

Blue Diamond is continually working to improve its products. Blue Diamond reserves the right to make any improvements or changes as deemed practical and possible without incurring any responsibility or obligation to make any changes or additions to equipment sold previously.

Although great care has been taken to ensure the accuracy of this publication, Blue Diamond makes no warranty or guarantee of any kind, written or expressed, implied or otherwise with regard to the information contained within this manual. Blue Diamond assumes no responsibility for any errors that may appear in this manual and shall not be liable under any circumstances for incidental, consequential or punitive damages in connection with, or arising from the use of this manual.

Keep this manual available for frequent reference. All new operators or owners must review the manual before using the equipment and annually thereafter. Contact your Blue Diamond Attachments Dealer for assistance, information, or additional copies of the manual. Contact [www.bluediamondattachments.com](http://www.bluediamondattachments.com) or call 888-376-7027 for a complete list of dealers in your area.

## Serial Number Location:

Please record attachment information in the space provided for future reference.



Model Number: \_\_\_\_\_

Serial Number: \_\_\_\_\_

Dealer Name: \_\_\_\_\_

Dealer Number: \_\_\_\_\_

Date of Purchase: \_\_\_\_\_

The serial number plate is located on the front of the mount plate on the right hand side.

Always use your serial number when requesting information or when ordering parts.

**NOTE:** The directions left, right, front and rear, as mentioned throughout this manual, are as viewed from the operator's position.

# Table of Contents

---

1. Introduction.....	4-5
1.1 Attachment Identification.....	4
2. Safety .....	5-7
2.1 General Safety Information.....	5
2.2 Important Safety Guidelines.....	7
3. Set Up .....	8-14
3.1 General Information.....	8
3.2 Attachment Inspection.....	9
3.3 Attachment Installation.....	10
3.4 Operating the Attachment .....	12
4. Maintenance .....	15-19
4.1 Maintenance Safety.....	15
4.2 Lubrication.....	16
4.3 Broom Adjustment.....	16
4.4 Removal and Installation .....	17
4.5 Cleaning the Attachment.....	18
5. Parts.....	18-28
5.1 Angle Broom Parts Breakdown.....	18
5.2 Hardware.....	23
5.3 Hydraulic Angle Kit.....	26
6. Specifications .....	29-31
6.1 Attachment Specifications .....	29
6.2 Performance Specifications.....	30
6.3 Torque Specifications.....	31
7. Warranty .....	33

# 1. Introduction

---

## 1.1 Attachment Identification

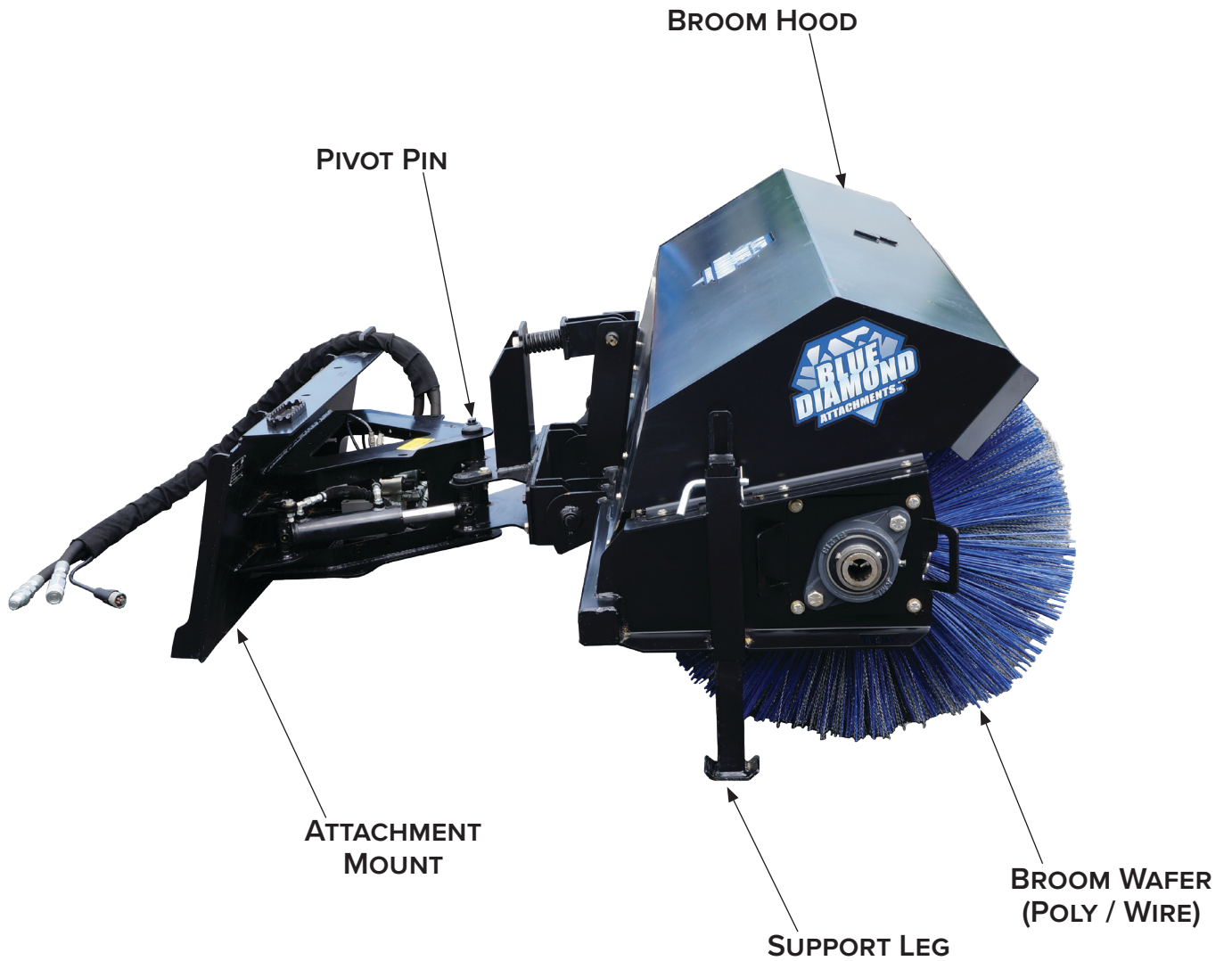



## 2. Safety

### 2.1 General Safety Information



This SAFETY ALERT SYMBOL identifies important safety messages on the equipment and in the owner's manual. When you see this symbol, be alert to the possibility of personal injury and carefully read the message that follows.



The signal word **IMPORTANT** identifies procedures which must be followed to avoid damage to the machine.



The signal word **DANGER** on the machine and in the manuals indicates a hazardous situation which, if not avoided, will result in death or serious injury.



The signal word **WARNING** on the machine and in the manuals indicates a potentially hazardous situation which, if not avoided, could result in death or serious injury.



The signal word **CAUTION** on the machine and in the manuals indicates a potentially hazardous situation which, if not avoided, may result in minor or moderate injury. It may also be used to alert against unsafe practices.

### Safe Operation Needs a Qualified Operator



#### AVOID SERIOUS INJURY OR DEATH

Operators must receive instructions before operating the machine. Untrained operators can cause serious injury or death. For an operator to be qualified, he or she must not use drugs or alcoholic drinks which impair alertness or coordination while working. An operator who is taking prescription drugs must get medical advice to determine if he or she can safely operate a machine and the equipment.

### Operator Training

- Check the rules and regulations at your location. The rules may include an employer's work safety requirements. Regulations may apply to local driving requirements or use of a Slow Moving Vehicle (SMV) emblem. Regulations may identify a hazard such as a utility line.
- The new operator must start in an area without bystanders and use all the controls until he or she can operate the machine safely under all conditions of the work area.

## 2. Safety

---

### 2.1 Important Safety Guidelines

#### Operating Safety

- Read and follow instructions in this manual and the machine's Operator's Manual before operating. Operate equipment according to both manuals
- Under no circumstances should young children be allowed to work with this equipment.
- This equipment is dangerous to persons unfamiliar with its operation.
- Check for overhead and/or underground lines before operating equipment (if applicable).
- In addition to the design and configuration of equipment, hazard control and accident prevention are dependent upon the awareness, concern, prudence, and proper training of personnel involved in the operation, transport, maintenance, and storage of equipment.
- Check that the attachment is securely fastened to the machine.
- Make sure all the machine controls are in NEUTRAL before starting the machine.
- Operate the equipment only from the operator's position.
- When learning to operate the equipment, do it at a slow rate in an area clear of bystanders.
- DO NOT permit personnel to be in the work area when operating the equipment.
- The equipment must be used ONLY on approved machines.
- DO NOT modify the equipment in any way. Unauthorized modification may impair the function and/or safety and could affect the life of the equipment.
- DO NOT make any adjustments or repairs on the equipment while the machine is running.
- Keep shields and guards in place. Replace if damaged.
- DO NOT operate equipment in poor visibility conditions such as fog, darkness, or any conditions that limit clear visibility less than 300 feet (100 m) in front of and to the sides of the equipment.
- When conditions make it necessary to slow ground speed, shift to a lower gear rather than reducing engine speed. The engine will maintain rated speed and keep broom running at optimum sweeping speed.
- DO NOT operate in a work area that has not been inspected for foreign debris and obstacles.
- Remove any foreign objects and clearly mark any objects that cannot be removed.
- Wear safety glasses, gloves, hearing protection, and other protective clothing when required.

#### Machine Requirements and Capabilities

- It is recommended that the machine's operator's cab should be equipped with a thermoplastic polycarbonate or similar material front window, and similar protection on the sides of the operator's cab before operating the equipment.
- Keep bystanders clear of moving parts and the work area. Keep children away.
- DO NOT exceed 3500 psi (241 bar) operating pressure.
- Use caution on slopes and near banks and ditches to prevent overturn.

## 2. Safety

---

### Fire Prevention Safety

- Flammable debris (leaves, grass, etc) must be removed regularly. If flammable debris is allowed to accumulate, it can cause a fire hazard. Clean often to avoid this accumulation.
- The equipment's hydraulic motor compartment must be inspected every day and cleaned if necessary to prevent fire hazards and overheating.
- All fuels, most lubricants and some coolant mixtures are flammable. Flammable fluids that are leaking or spilled onto hot surfaces or onto electrical components can cause a fire.

### Transport Safety

- Comply with state and local laws governing highway safety and movement of machinery on public roads.
- Check local laws for all highway lighting and marking requirements.
- Always yield to oncoming traffic and move to the side of the road so any following traffic may pass.
- Never allow riders on either machine or equipment.
- If transporting the angle broom on a truck or trailer, make sure the angle broom is properly secured to the transport vehicle.

### Hydraulic System

- Check hydraulic tubes, hoses and fittings for damage and leakage. Never use open flame or bare skin to check for leaks. Hydraulic tubes and hoses must be properly routed and have adequate support and secure clamps. Tighten or replace any parts that show leakage
- Always clean fluid spills. Do not use gasoline or diesel fuel for cleaning parts. Use commercial nonflammable solvents.

## 3. Operation

### 3.1 General Information

#### Safe Operation Needs a Qualified Operator

Before operating the Severe Duty Series 2 Angle Broom for the first time and each time thereafter, use the following list as a guideline during equipment inspection.



#### WARNING



##### AVOID SERIOUS INJURY OR DEATH

- Disengage machine's auxiliary hydraulics, engage the machine's parking brake, stop the engine and make sure all rotating components are completely stopped before connecting, disconnecting, adjusting, or cleaning equipment.
- Always keep shields and all guards in place when using the equipment.
- Disengage machine's auxiliary hydraulics for road travel.
- Keep hands, feet, and clothing away from rotating parts.

- Fully clean the attachment. See "Cleaning The Attachment" on page 19.
- Lubricate the attachment as explained in the Maintenance Section. See "Lubrication" on page 16.
- Check the angle broom mounting plate for damage. Check for loose or missing parts. Repair as needed before operation.
- Check that broom wafers are in good condition. Replace them as necessary.
- Check that all shields and guards are in place.
- Check for loose bolts and tighten them if necessary.

- Check all welds on the attachment for wear and damage each time the attachment is removed from the machine.
- Check for damaged or missing safety decals. Replace if necessary.
- Inspect the machine's mounting frame. (See the machine's Operator's Manual for inspecting the mounting frame). Replace any parts that are damaged, bent or missing. Keep all fasteners tight. Look for cracked welds.



#### WARNING



Leaking fluids under pressure can enter the skin and cause serious injury or death. Immediate medical attention is required. Wear goggles. Use cardboard to check for leaks.

- Check condition of all hydraulic components for leaks. Repair as required.
- NOTE:** Do not operate with hydraulic leaks.
- Verify that the angle broom is properly connected

## 3. Operation

### 3.2 Attachment Inspection

#### Daily Inspection

**NOTE:** Inspect the attachment by performing a walk around daily before and after use. Use the following inspection checklist as a guideline.

Check the following items every 10 hours of operation:

	ITEMS
✓	Verify that the angle broom is properly connected to the machine.
✓	Check that all shields and guards are in place.
✓	Check hydraulic lines, connections, and fittings for hydraulic oil leaks. Repair or replace damaged parts if necessary.
✓	Check the angle broom mounting hardware for wear or damage. Inspect the pins and mount (on the attachment) for wear or damage. Repair or replace damaged parts if necessary.

#### Weekly Inspection

Check the following items every 40 hours of operation:

	ITEMS
✓	Check all bolts for tightness.
✓	Inspect the frame for cracks, bends, or damage.

#### Monthly Inspection

	ITEMS
✓	Inspect the broom wafers for excessive wear.
✓	Check that all bolts are tight.
✓	Check frame, shields, and guards. Repair if damaged or replace if necessary.
✓	Check for damaged or missing decals. Replace if necessary.
✓	Check for damaged or leaking hydraulic hoses or fittings. Replace if necessary.
✓	Clean all debris, leaves, grass, and flammable material from deck area and under covers.
✓	Lubricate as required.



### WARNING



#### AVOID SERIOUS INJURY OR DEATH

Before servicing the attachment:

- Always park on a flat level surface.
- Lower lift arms and place attachment flat on the ground.
- Place all controls in NEUTRAL.
- Engage the park brake.
- Wait for all moving parts to stop.
- Stop the engine and remove the key.

**SEE MACHINE OPERATOR'S MANUAL FOR ADDITIONAL INFORMATION.**

## 3. Operation

### 3.3 Attachment Installation



See the machine's Operator's Manual for detailed information on operating the loader.

#### Entering The Operator's Position

Use the attachment safety treads, handles and steps (on the machine) to enter the operator's position.

When in the operator's position, lower safety seat bar, start the engine and release the parking brake.

#### Leaving The Operator's Position



##### AVOID SERIOUS INJURY OR DEATH

- Always park on a flat level surface.
- Lower lift arms and place attachment flat on the ground.
- Place all controls in NEUTRAL.
- Engage the park brake.
- Stop the engine and remove the key.
- Wait for all moving parts to stop.

**SEE MACHINE'S OPERATOR'S MANUAL FOR ADDITIONAL INFORMATION.**

Park the machine / attachment on a flat level surface.

Place all controls in neutral, engage the park brake, stop the engine and wait for all moving parts to stop. Leave the operator's position.

### Connecting Attachment To The Machine



##### CRUSH HAZARD

- Before moving the machine, look in all directions and make sure no bystanders, especially small children are in the work area. Do not allow anyone between the machine and attachment when approaching the attachment for connecting.
- Keep fingers and hands out of pinch points when connecting and disconnecting the attachment.

Before connecting to the attachment, inspect the machine's mounting plate. (See the machine's Operator's Manual for inspecting the mounting frame).

Enter the operator's position. See "Entering The Operator's Position" on page 10.

Drive the machine slowly forward, until the top edge of the machine's mounting plate is under the top flange of the attachment mounting frame.

Slowly tilt the machine's mounting plate back until the attachment mounting frame fully contacts the front of the machine's mounting plate.

Leave the operator's position. See "Leaving The Operator's Position" on page 10.



##### AVOID SERIOUS INJURY OR DEATH

The locking pins / wedges must extend through the holes in the attachment mounting frame. Failure to secure locking pins / wedges can allow attachment to come off.

**SEE MACHINE'S OPERATOR'S MANUAL FOR ADDITIONAL INFORMATION.**



### 3. Operation

Engage attachment locking levers / wedges (See the machine's Operator's Manual for detailed information).

#### Connecting Hydraulic Hoses



Thoroughly clean the quick couplers before making connections. Dirt can quickly damage the hydraulic system.

Remove dirt or debris from the male and female couplers. Visually inspect the couplers for corroding, cracking, damage, or excessive wear. Replace as needed.

Connect the attachment hydraulic hoses to the machine. Pull on each hose to verify full connection is made.

#### Disconnecting Hydraulic Hoses



##### **AVOID SERIOUS INJURY OR DEATH**

Hydraulic fluid, tubes, fittings, and quick couplers can get hot during operation. Be careful when connecting and disconnecting hydraulic hoses.

Relieve auxiliary hydraulic pressure. (See the machine's Operator's Manual for correct procedure.)

Disconnect attachment hydraulic hoses from the machine.

#### Disconnecting Attachment From the Machine

Relieve auxiliary hydraulic pressure. (See the machine's Operator's Manual for correct procedure.)

Park the machine and attachment on a flat level surface. Lower the attachment flat on the ground.

Leave the operator's position. See "Leaving The Operator's Position" on page 10.

Disconnect attachment hydraulic hoses from the machine.

Disengage locking pins / wedges. (See the machine's Operator's Manual for correct procedure.)

Enter the operator's position. See "Entering The Operator's Position" on page 10.

Slowly tilt the machine's mounting plate forward until the attachment mounting frame is free from the machine's mounting plate.

Drive the machine slowly backward, away from the attachment.

### 3. Operation

#### 3.4 Operating the Attachment

##### Machine Requirements



**FLYING DEBRIS OR OBJECTS WILL CAUSE SERIOUS INJURY OR DEATH**

To protect the operator from any flying debris or objects, it is important that the machine's operator's cab should be equipped with a thermoplastic polycarbonate or similar material front window, and similar protection on the sides of the operator's cab before operating the Severe Duty Series 2 Angle Broom.

- It's recommended that the machine be equipped with a thermoplastic polycarbonate or similar material front window, and similar protection on the sides of the operator's cab.
- Only use broom on compatible loaders. Loader flow must not exceed 25 gallons per minute. DO NOT USE high flow hydraulics.
- Loader relief pressure must not exceed 3500 PSI (241 bar). Consult loader manual for flow and pressure specifications.
- See chart below for minimum lift capacity required for each angle broom model.

SEVERE DUTY ANGLE BROOM MODEL	WEIGHT
60"	995 lbs (451 kg)
72"	1125 lbs (510 kg)
84"	1300 lbs (590 kg)
96"	1450 lbs (658 kg)

##### Operation



**THROWN OBJECTS OR ROTATING BLADES CAN CAUSE SERIOUS INJURY OR DEATH**

- Clear work area of all debris, such as rope, wire, cable or other materials that can wrap around broom core causing entanglement and attachment damage.
- DO NOT operate broom in vicinity of bystanders, animals, or damageable property. Objects can be thrown great distances
- Keep all shields installed. Repair or replace if damaged or missing.
- Check broom core. Replace if damaged. Never weld or modify.



**AVOID SERIOUS INJURY OR DEATH**

Never operate the angle broom with any guards removed, including the motor cover.



**AVOID SERIOUS INJURY OR DEATH**

Never allow riders on the angle broom.

## 3. Operation

---

### Operation Cont'd

#### *Using the Angle Broom*

Install the Severe Duty Series 2 Angle Broom onto the machine.

Move storage feet to the upper position.

Move to the operator's position, lower seat bar, start the engine, and release the parking brake.

Raise the angle broom approximately 6 in. (152 mm) off the ground.

With the machine's engine RPM just above idle, engage the auxiliary hydraulic flow (see the machine's operator's manual) to the cutter head.

Slowly raise the machine's engine RPM to the correct and desired broom speed.



### CAUTION



**DO NOT** exceed 3500 PSI operating pressure. Serious damage can result.

Adjust angle broom so the broom pivot pin is perpendicular to the ground, this ensures even sweeping when the broom is angled. The ends of the broom will rise or lower when angled if broom pivot pin is not perpendicular to the ground.

Limit travel speed to 5 mph.

Adjust brush using loader tilt to give a 2"– 4" wide pattern. Excessive down force will prematurely wear wafers.

Slow down in heavy material. Allow time for the broom to sweep.

### Storage

DO NOT store the polypropylene brush wafers in direct sun light. The material can deteriorate.

Park the machine and attachment on a flat level surface.

Raise broom housing, keeping the broom wafers 2"– 4" above the ground.

Relieve auxiliary hydraulic pressure. (See the machine's Operator's Manual for correct procedure.)

Leave the operator's position. See "Leaving The Operator's Position" on page 10.

Remove storage feet pins and move storage feet to lower position and replace pins.

Disconnect attachment hydraulic hoses from the machine.

Disengage locking pins / wedges. (See the machine's Operator's Manual for correct procedure.)

Enter the operator's position. See "Entering The Operator's Position" on page 10.

Lower angle broom setting the storage feet on the ground.

Slowly tilt the machine's mounting plate forward until the attachment mounting frame is free from the machine's mounting plate.

Drive the machine slowly backward, away from the attachment.

## 3. Operation

---

### Operation Cont'd

#### *Angling Broom using the Manual Angle*

Raise the broom slightly above the ground with the pivot pin vertical.

Remove angle pin connecting the two angle links.

Manually swing the broom all the way left or right and replace angle link pin.

#### *Angling Broom using the Hydraulic Angle*

With the loader at low throttle, engage auxiliary hydraulics to start the broom motor.

Activate electrical control (in cab or optional control box) to select angle function to swing left or right.

**NOTE:** Broom motor must be running to adjust broom angle.

#### *Changing Sweeping Direction on Manual Angle Units*

Lower machine RPM to just above idle.

Stop hydraulic flow, and restart in the opposite direction.

Slowly raise the machine's engine RPM to the correct and desired broom speed.

#### *Changing Sweeping Direction on Hydraulic Angle Units*

Lower machine RPM to just above idle.

Stop hydraulic flow.

Using the electrical auxiliary control, change the flow direction to the motor.

Restart hydraulic flow.

Slowly raise the machine's engine RPM to the correct and desired broom speed.

**NOTE:** Changing flow direction from the host machine will not change sweeping direction on hydraulic angle units. Sweeping direction is a function of the electrical control harness.

#### *Optional Water Kit*

Check the strainer bowl daily for dirt and debris. This debris can plug the nozzles.

Check nozzles daily for debris. Remove and clean plugged nozzles.

## 4. Maintenance

### 4.1 Maintenance Safety



#### WARNING



##### AVOID SERIOUS INJURY OR DEATH

Never operate the machine in a closed building. Proper ventilation is required when operating the machine under all circumstances.

- Always keep the work area clean and dry.
- Always use personal protective equipment (PPE) such as eye, hand, and hearing protection when performing any service or maintenance.
- A fire extinguisher and first aid kit should be readily accessible while performing maintenance on this machine.
- Before working or doing maintenance on this machine, shut off the engine and remove the key. Make sure the machine's wheels are blocked.
- Never work under the machine or attachment unless the machine or equipment is blocked or supported securely.
- Disconnect the battery (both terminals) before welding on any part of the machine. Failure to do so may cause damage to electrical components.
- When working around batteries, remember that all of the exposed metal parts are "live". Never lay a metal object across the terminals because a spark, short circuit, explosion, or personal injury may result.
- Battery posts, terminals, and related accessories contain lead and lead compounds. Wash hands after handling.
- Always relieve hydraulic system pressure before repairing, adjusting, or disconnecting. Never search for leaks with your hands. (See "Hydraulic System" on page 8).
- When replacement parts are necessary, genuine factor replacement parts must be used to restore your equipment to original specifications. Blue Diamond® will not be responsible for injuries or damaged caused by use of unapproved parts and/or accessories.

- When completing service or maintenance on this machine, make sure all shields and guards are installed before placing the machine into service.

#### General Maintenance



#### WARNING



##### AVOID SERIOUS INJURY OR DEATH

Before operating or servicing system: Read and understand the machine's owners manual. Follow the warnings and instructions in the manual when making repairs, adjustments, or servicing. Check for correct function after adjustments, repairs, or service. Untrained operators and failure to follow instructions can cause injury or death.

To ensure efficient operation, you should inspect, lubricate, and make necessary adjustments and repairs at regular intervals. Keep good maintenance records and adequately clean your machine after each use.

Proper lubrication is important. Follow all lubrication instructions and schedules included in this section.

#### Daily Inspection:

	ITEMS
✓	All components and hardware to ensure equipment is secure and thoroughly tightened.
✓	Frame and all welds for cracks or damage.
✓	Mounting frame for proper operation and signs of damage or unusual wear.
✓	Safety signs and reflectors for damage. Replace any missing or damaged decals.
✓	Broom wafers for excessive wear or damage.
✓	Hydraulic hoses and fittings for wear, damage, or leaks.

## 4. Maintenance

### Daily Inspection Cont'd:

NOTE: Repair or replace any damaged parts.

NOTE: After initial use, or repair/replacement of damaged parts, it is important to check the repaired or replaced parts for proper bolt torque and operation.

### 4.2 Lubrication



Fluid such as hydraulic fluid, coolants, grease, etc. must be disposed of in an environmentally safe manner. Some regulations require that certain spills and leaks on the ground must be cleaned in a specific manner. See local, state, and federal regulations for the correct disposal.

Grease the following lube points EVERY 40 HOURS (weekly). always use a quality lithium base multi-purpose grease when lubricating the attachment.

#### Broom Angle Vertical Point

This zerk is located on the back of the vertical angle pivot. Apply 3-4 pumps of grease to the grease zerk.

#### Broom Angle Horizontal Pivot

These two zerks are located on each side of the broom in front of the vertical pivot pin on the intermediate frame. Apply 3-4 pumps of grease to each grease zerk.

#### Broom Height Adjustment Yoke

This zerk is located on the adjustment yoke near the broom height adjustment bolt. Apply 3-4 pumps of grease to the grease zerk.

### Right Side Bearing

This zerk is located on the bearing on the right side of the broom. Apply 3-4 pumps of grease to the grease zerk.

## 4.3 Broom Adjustment

### Broom Height and Pattern Adjustment

The broom height must be adjusted when the broom is new and as wafer bristles wear. The brush pattern should be checked and adjusted every 8 hours or daily. To check and adjust the pattern use the following steps.

1. Move the broom to a dusty flat surface.
2. With the loader at low throttle, start the broom motor.
3. Slowly lower the broom until it is in the operating position; typically, loader arms down and loader attach surface vertical.
4. Keep the broom in this position for 10 seconds. Do not move loader.
5. Raise broom, stop the broom motor, and move the loader back several feet. Lower broom to ground and exit loader. See "Leaving the Operator's Position" on page 10.

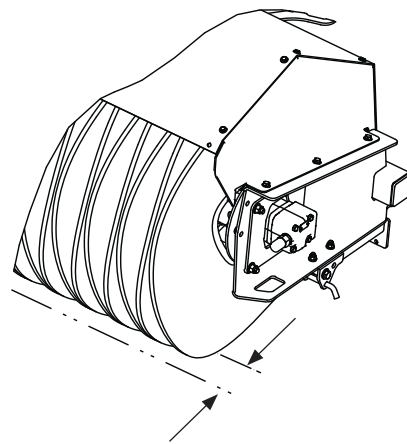

Figure 1

6. Measure pattern width left by broom. Pattern should be 2"-4" wide and even across the width of the broom [Figure 1].



## 4. Maintenance

---

### 4.4 Removal and Installation

#### Broom Core

See parts section for parts diagrams.

1. Park the machine and attachment on a flat level surface. Lower the attachment flat on the ground.
2. Leave the operator's position. See "Leaving the Operator's Position" on page 10.
3. Disconnect attachment hydraulic hoses from the machine.
4. Remove motor to broom housing hardware and remove motor subassembly. Motor hoses can remain connected.
5. Remove bearing housing hardware and remove bearing assembly.
6. Using the skid loader or a housing, raise broom housing off of broom core. Roll broom core away from frame.
7. To install broom core, repeat the steps in reverse order.

#### Broom Wafers

See parts section for parts diagrams.

1. Park the machine and attachment on a flat level surface. Lower the attachment flat on the ground.
2. Leave the operator's position. See "Leaving the Operator's Position" on page 10.
3. Disconnect attachment hydraulic hoses from the machine.
4. Remove broom core. See "Broom Core" on page 17.
5. Remove broom drum retaining plate from end of broom core.
6. Stand broom core on end with assembled retaining plate and remove broom wafers.
7. Install new wafer making sure wafer retention pins are trapped on broom drum bar.

8. Install remaining broom wafers alternating steel and poly wafers. The retention pins on consecutive wafers should alternate 180 degrees and be trapped by opposite bars
9. Install last broom wafer and install broom drum retaining plate. Carefully lay the broom core on its side.
10. Move broom core under broom housing and lower housing on core.
11. Replace bearing plate and motor plate hardware. Tighten hardware.
12. Replace motor, bearing, and hardware. Tighten hardware.

#### Broom Motor

See parts section for parts diagrams.

1. Park the machine and attachment on a flat level surface. Lower the attachment flat on the ground.
2. Leave the operator's position. See "Leaving the Operator's Position" on page 10.
3. Disconnect attachment hydraulic hoses from the machine.
4. Remove motor guard hardware and motor guard.
5. Remove and cap motor hoses.
6. Remove motor hardware and remove motor subassembly from broom housing.
7. Remove motor can hardware and remove motor.
8. Reassemble in reverse order.

## 4. Maintenance

---

### Bearing

See parts section for parts diagrams.

1. Park the machine and attachment on a flat level surface. Lower the attachment flat on the ground.
2. Leave the operator's position. See "Leaving The Operator's Position" on page 10.
3. Disconnect attachment hydraulic hoses from the machine.
4. Remove bearing housing hardware.
5. Remove bearing.
6. Reassemble in reverse order.

### 4.5 Cleaning the Attachment



**DANGER**



#### **AVOID SERIOUS INJURY OR DEATH**

Before servicing the Angle Broom:

- Disconnect attachment hydraulic hoses.
- Fully lower the lift arms and tilt angle broom forward (down) until the support feet contact the ground.
- Engage parking brake, stop engine, and exit the machine.

Park the machine and attachment on a flat level surface. Lower the attachment flat on the ground.

Leave the operator's position. See "Leaving The Operator's Position" on page 10.

Disconnect attachment hydraulic hoses from the machine.

Enter the operator's position. See "Entering The Operator's Position" on page 10.

Start the engine, fully lower the machine's lift arms, while tilting the angle broom forward (down) until the support feet contact the ground.

Stop the engine, engage parking brake and leave the operator's position. See "Leaving The Operator's Position" on page 10.

Use water or air pressure to clean debris from under the angle broom frame/shields.

Be careful when removing any obstructions that are wrapped around broom core or broom wafers.

## 5. Parts

### 5.1 Angle Broom Parts Breakdown

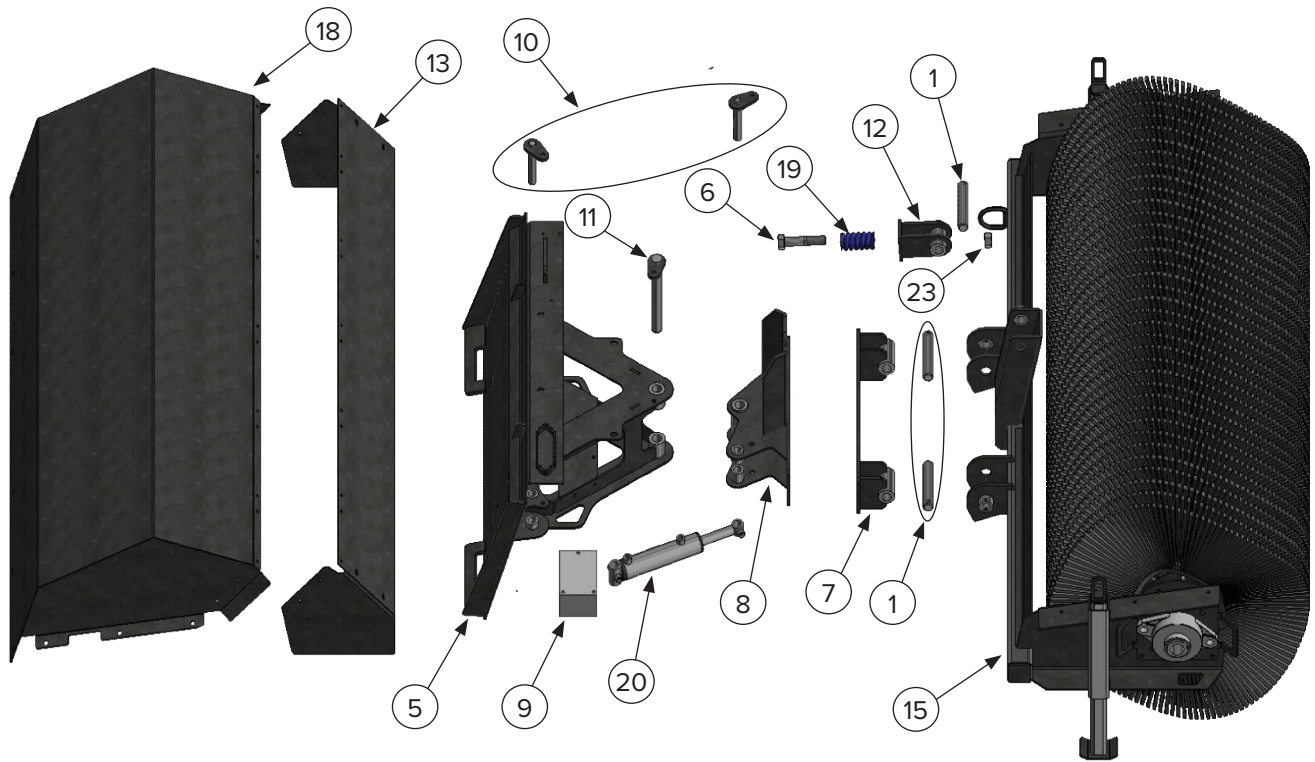

## 5. Parts

### 5.1 Angle Broom Parts Breakdown

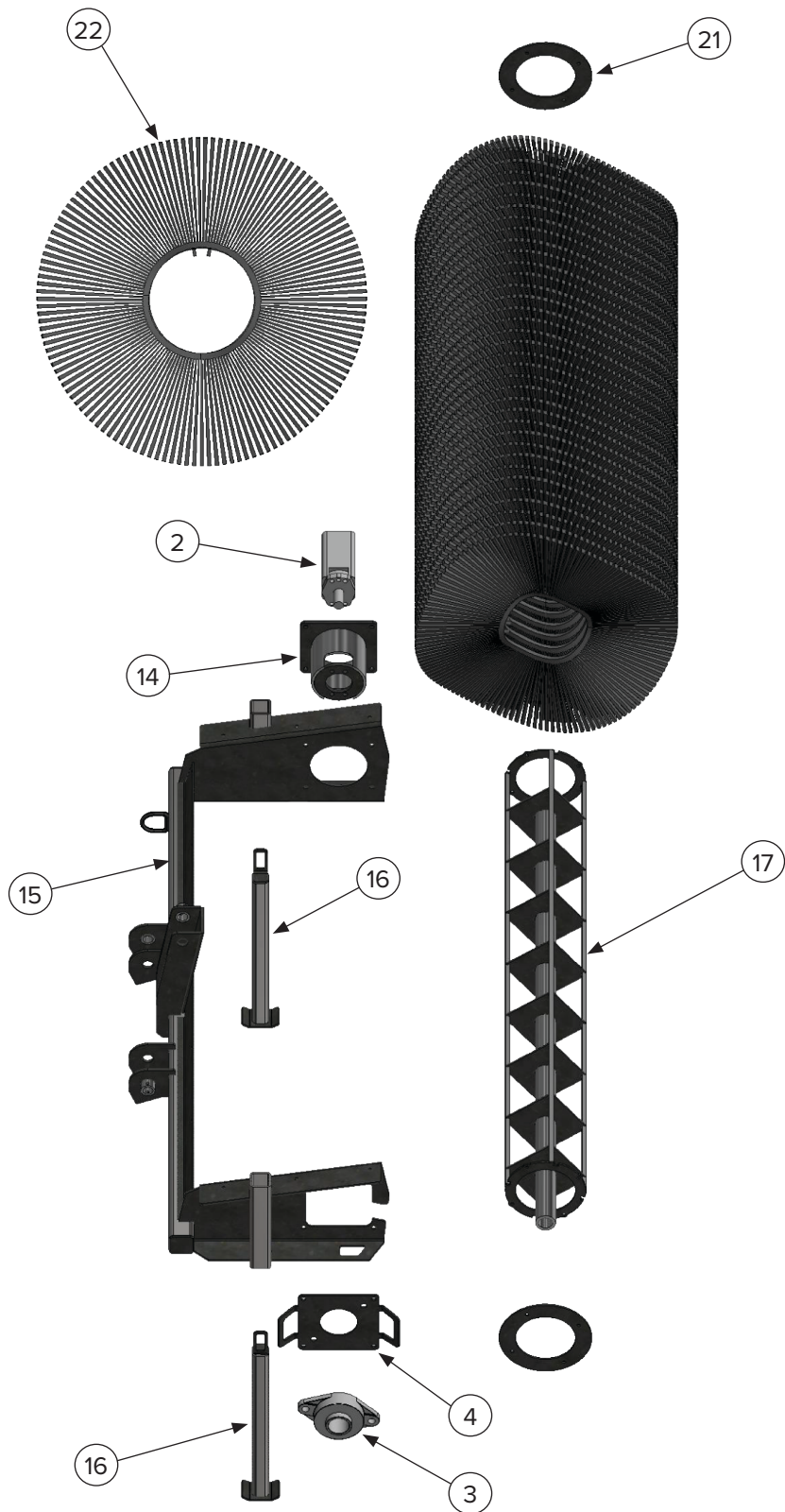

## 5. Parts

### 5.1 Angle Broom Parts Breakdown

ITEM	PART NUMBER	DESCRIPTION	QTY 60"	QTY 72"	QTY 84"	QTY 96"
1	216740	Pivot Pin 7.5 x 1.25	3	3	3	3
2	216705	Motor	1	1	1	1
3	216741	Bearing	1	1	1	1
4	216758	Bearing Mount Plate	1	1	1	1
5	216745	Mount Weldment	1	1	1	1
6	299493	Spring Bolt	1	1	1	1
7	216742	Front Hinge Bracket	1	1	1	1
8	216747	Main Frame Pivot Weldment	1	1	1	1
9	216743	Hydraulic Manifold Block	1	1	1	1
10	216722	Cylinder Pins	2	2	2	2
11	216721	Main Frame Pivot Pin	1	1	1	1
12	216760	Spring Bracket	1	1	1	1
13	216262-60	Hood Extension 60"	1	—	—	—
	216262-72	Hood Extension 72"	—	1	—	—
	216262-84	Hood Extension 84"	—	—	1	—
	216262-96	Hood Extension 96"	—	—	—	1
14	216744	Motor Mount Weldment	1	1	1	1
15	216750-60	Frame Weldment 60"	1	—	—	—
	216750-72	Frame Weldment 72"	—	1	—	—
	216750-84	Frame Weldment 84"	—	—	1	—
	216750-96	Frame Weldment 96"	—	—	—	1
16	216752	Support Leg	2	2	2	2
NS	270505	Support Leg Pin	2	2	2	2

## 5. Parts

### 5.1 Angle Broom Parts Breakdown

ITEM	PART NUMBER	DESCRIPTION	QTY 60"	QTY 72"	QTY 84"	QTY 96"
17	216607	Broom Hub 60"	1	—	—	—
	216608	Broom Hub 72"	—	1	—	—
	216606	Broom Hub 84"	—	—	1	—
	216609	Broom Hub 96"	—	—	—	1
18	216756-60	Hood 60"	1	—	—	—
	216756-72	Hood 72"	—	1	—	—
	216756-84	Hood 84"	—	—	1	—
	216756-96	Hood 96"	—	—	—	1
19	216241	Spring	1	1	1	1
20	216158	Angle Cylinder - Hydraulic Only	1	1	1	1
NS	216784	Manual Angle Arm - Manual Only	1	1	1	1
21	216782	Bristle Retainer Ring	2	2	2	2
22	216205	Convolute Poly Wafer	14	17	20	23
	216207	Convolute Steel Wafer	15	18	21	24
	216209	Convolute Poly/Steel Wafer	29	35	41	47
23	299659	Spring Nut	1	1	1	1
NS	216746	Hose Set	1	1	1	1
<b>SEVERE DUTY SERIES 2 WIRING HARNESESSES</b>						
NS	103884	Wire Harness Attachment Side				
NS	103885	Wire Harness Machine Side Universal Control				
NS	103887	Wire Harness Machine Side 14-Pin				
NS	103888	Wire Harness Machine Side bobcat 7-Pin				
NS	103889	Wire Harness Machine Side 8-Pin				



## 5. Parts

### 5.2 Hardware

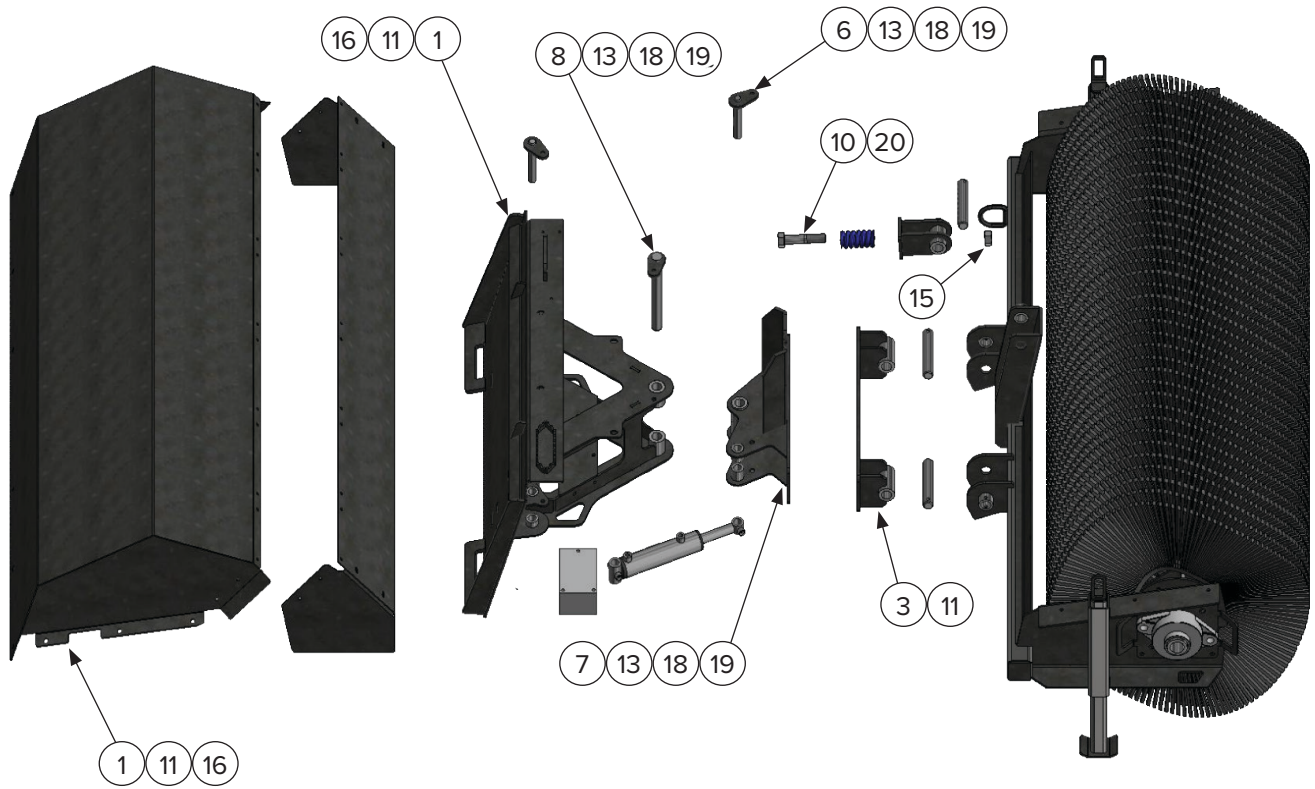

## 5. Parts

### 5.2 Hardware

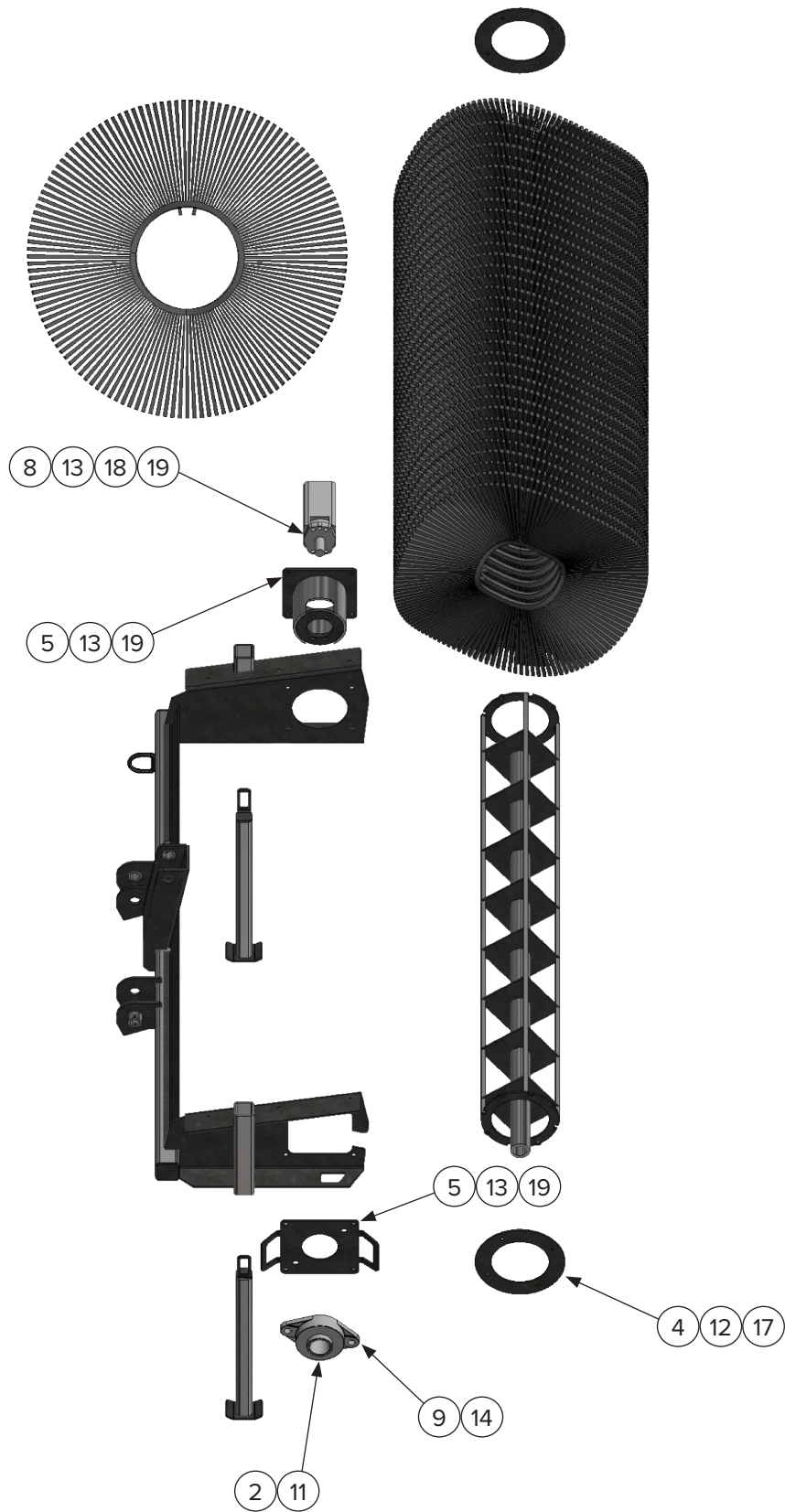

## 5. Parts

ITEM	PART NUMBER	DESCRIPTION	DIMENSIONS	QTY 60" & 72"	QTY 84" & 96"
1	299317	Manual Tube Bolt	5/16-18 x 1" Hex Head	3	3
	299317	Hood Bolt	5/16-18 x 1" Hex Head	12	14
2	299318	Bearing Shaft Retainer Bolt	5/16-18 x 1.5" Hex Head	2	2
3	299315	Hinge Pivot Pin Bolt	5/16-18 x 2.25" Hex Head	3	3
4	299428	Bristle Retainer Bolt	3/8-16 x 1.5" Hex Head	8	8
5	299344	Bearing Mount Plate Bolt	1/2-13 x 1.25" Hex Head	4	4
	299344	Motor Coupler Mount Bolt	1/2-13 x 1.25" Hex Head	4	4
6	299439	Cylinder/Angle Arm Pivot Pin Bolt	1/2-13 x 1.75" Hex Head	1	1
7	299433	Pivot/Spring Mount to Hinge Weldment Bolt	1/2-13 x 2" Hex Head	4	4
8	299474	Main Pivot Pin Bolt	1/2-13 x 2.5" Hex Head	1	1
	299474	Motor to Motor Coupler Bolt	1/2-13 x 2.5" Hex Head	4	4
9	299454	Bearing Mount Bolt	3/4-10 x 2" Hex Head	2	2
10	299493	Hinge Spring Bolt	1-8 x 6" Hex Head	1	1
11	299654	Manual Tube Nut	5/16" Stover	3	3
	299654	Hinge Pivot Pin Nut	5/16" Stover	3	3
	299654	Hood Nut	5/16" Stover	12	14
	299654	Bearing Shaft Retainer Nut	5/16" Stover	2	2
12	208550	Bristle Retainer Nut	3/8" Stover	8	8
13	299655	Main Pivot Pin Nut	1/2" Stover	1	1
	299655	Cylinder/Angle Arm Pivot Pin Nut	1/2" Stover	2	2
	299655	Pivot/Spring Mount to Hinge Weldment Nut	1/2" Stover	4	4
	299655	Bearing Mount Plate Nut	1/2" Stover	4	4
	299655	Motor to Motor Coupler Nut	1/2" Stover	4	4
	299655	Motor Coupler Mount Nut	1/2" Stover	4	4
14	299657	Bearing Mount Nut	3/4" Stover	2	2
15	299659	Hinge Spring Nut	1" Stover	1	1
16	299720	Manual Tube Washer	5/16" Washer	6	6
	299720	Hood Washer	5/16" Washer	24	28
17	299725	Bristle Retainer Washer	3/8" Washer	16	16
18	299830	Main Pivot Pin Lock Washer	1/2" Lock Washer	1	1
	299830	Cylinder/Angle Arm Pivot Pin Lock Washer	1/2" Lock Washer	2	2
	299830	Pivot/Spring Mount to Hinge Weldment Lock Washer	1/2" Lock Washer	4	4
	299830	Motor to Motor Coupler Lock Washer	1/2" Lock Washer	4	4
19	299732	Main Pivot Pin Washer	1/2" Washer	2	2
	299732	Cylinder/Angle Arm Pivot Pin Washer	1/2" Washer	4	4
	299732	Pivot/Spring Mount to Hinge Weldment Washer	1/2" Washer	8	8
	299732	Bearing Mount Plate Washer	1/2" Washer	8	8
	299732	Motor to Motor Coupler Washer	1/2" Washer	4	4
	299732	Motor Coupler Mount Washer	1/2" Washer	8	8
20	223178	Hinge Spring Washer	1" Washer (2.5" OD)	1	1



## 5. Parts

### 5.3 Hydraulic Angle Kit

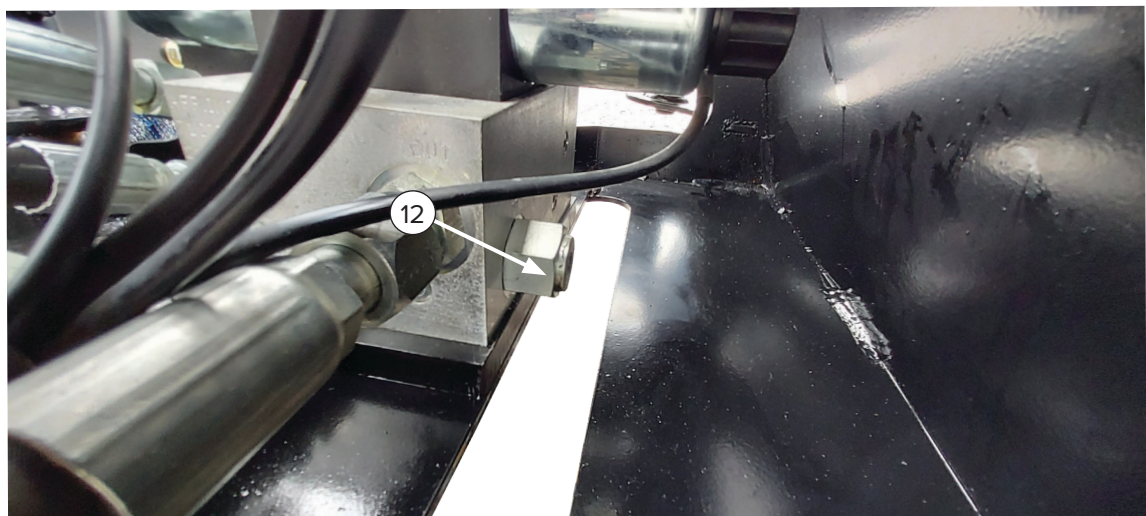
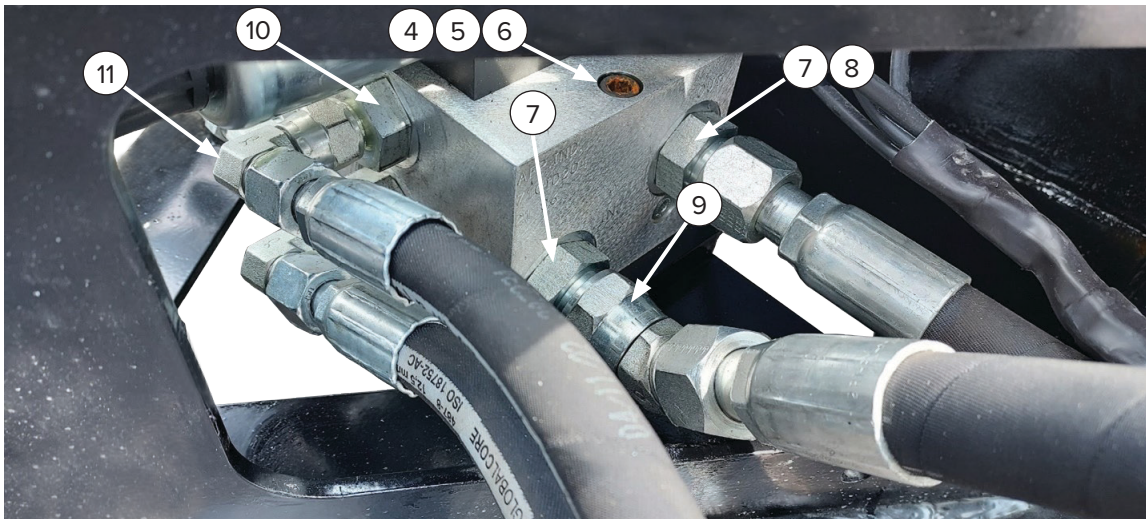
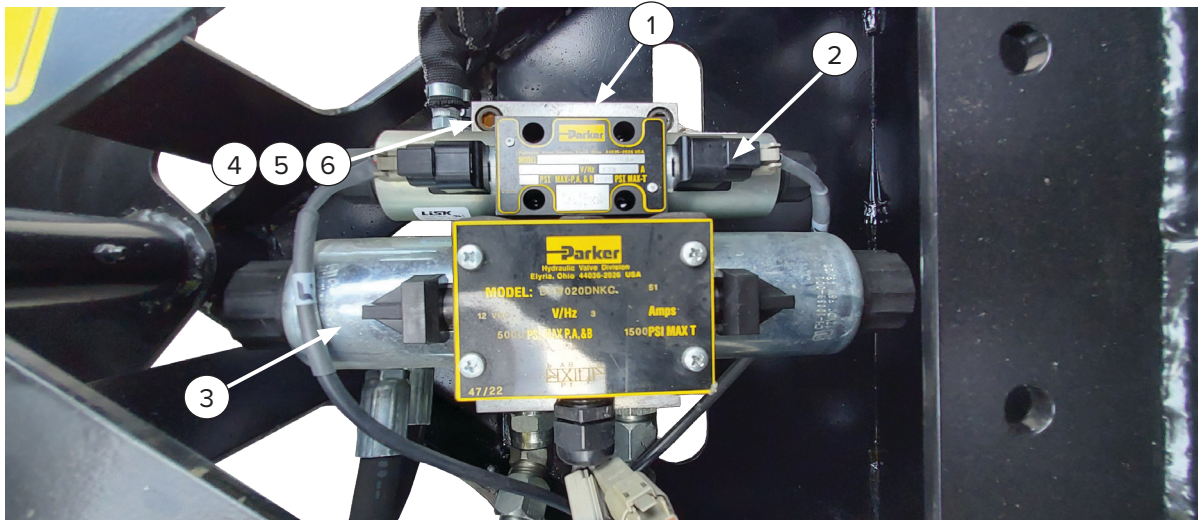



## 5. Parts

### 5.3 Hydraulic Angle Kit Cont'd

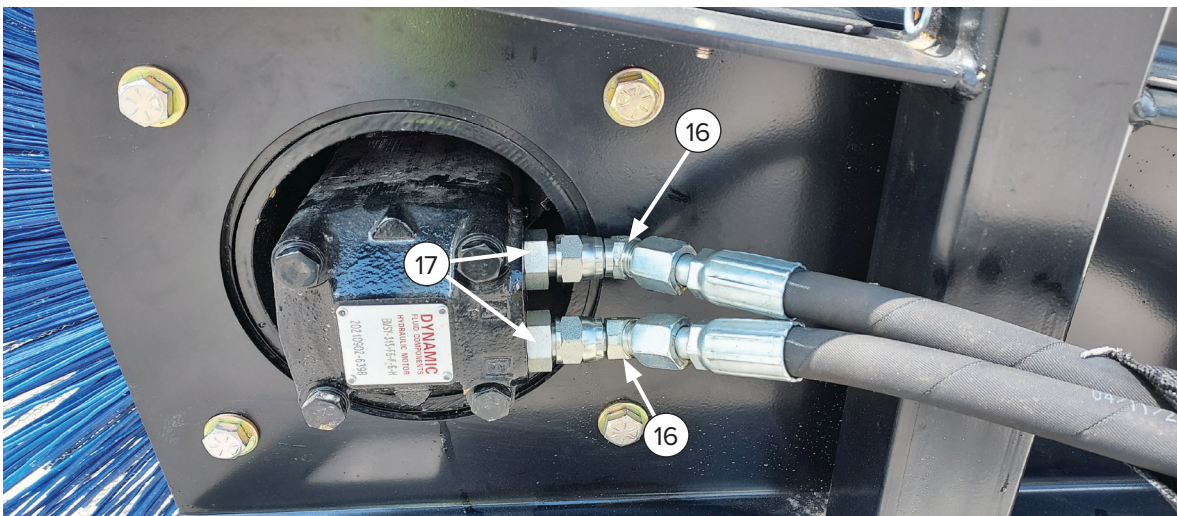
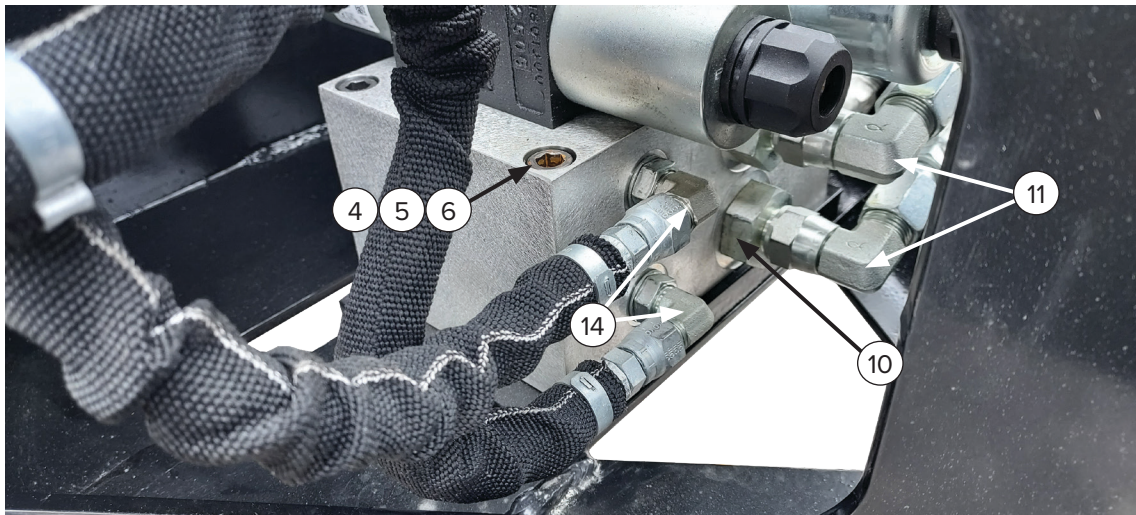
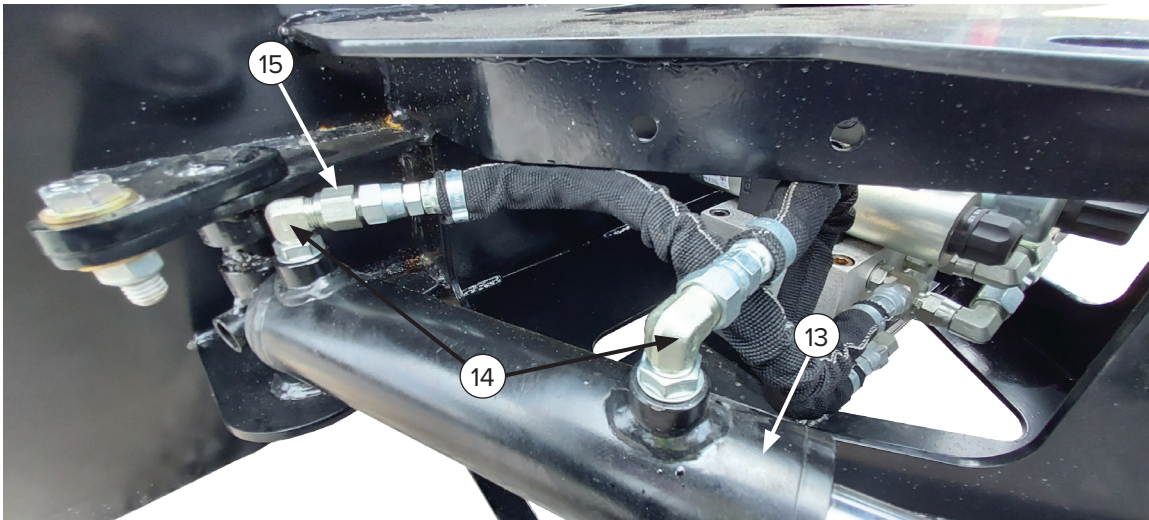

## 5. Parts

### 5.3 Hydraulic Angle Kit Cont'd

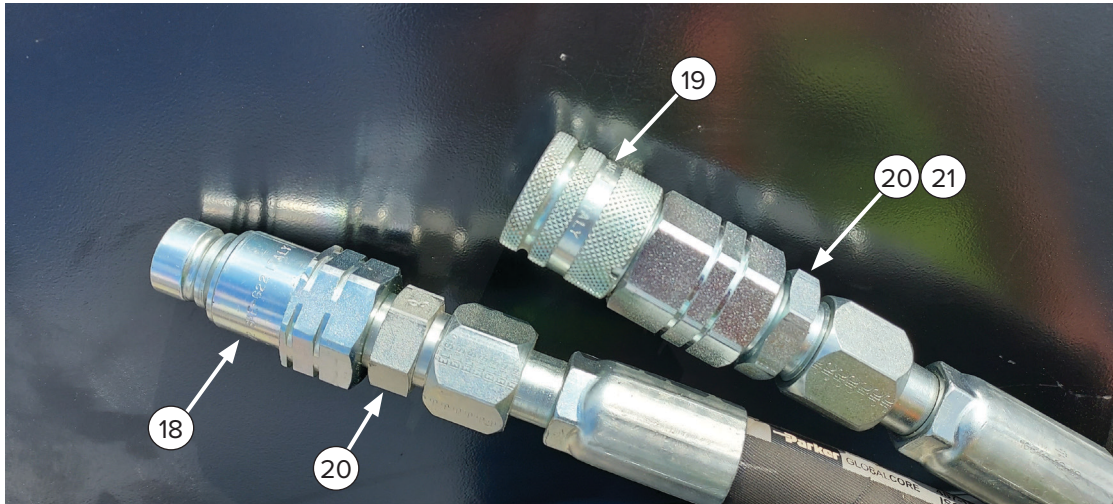

ITEM	PART NUMBER	DESCRIPTION	QTY
1	216743	Valve Block	1
2	216351	Solenoid – Small	2
3	216352	Solenoid – Large	2
4	299321	Valve Block Bolt 3/8" X 5" Socket Head Bolt	3
5	299724	Valve Block Washer 3/8"	3
6	208550	Valve Block Nut 3/8" Stover	3
7	295010-M12JIC-M12ORB	Supply/Return straight fittings at Valve Block	1 or 2
8	216354	Manifold Return Port Check Valve Fitting (not required if #21 is present)	0 or 1
9	295020-M12JIC-F12JIC	Supply 45 degree fitting at Valve Block	1
10	295010-M08JIC-M12ORB	Motor Supply/Return straight fittings at Valve Block	2
11	295030-M08JIC-F-8JIC	Motor Supply/Return 90 degree fittings at Valve Block	2
12	216748	Valve Block Cartridge	1
13	216158	Cylinder	1
14	295030-M06JIC-M08ORB	Cylinder Hose 90 degree fittings	4
15	206052	Cylinder Base End Straight Restrictor Fitting	1
16	295020-M08JIC-F08JIC	Motor 45 Degree Fittings	2
17	205010-M08JIC-M10ORB	Motor Straight Fittings	2
18	224010	Male Coupler	1
19	224009	Female Coupler	1
20	295010-M12JIC-M08ORB	Supply Line Coupler Fitting	1 or 2
21	216353	Return Line Check Valve Coupler Fitting (not required if #8 is present)	0 or 1



## 6. Specifications

### 6.1 Attachment Specifications

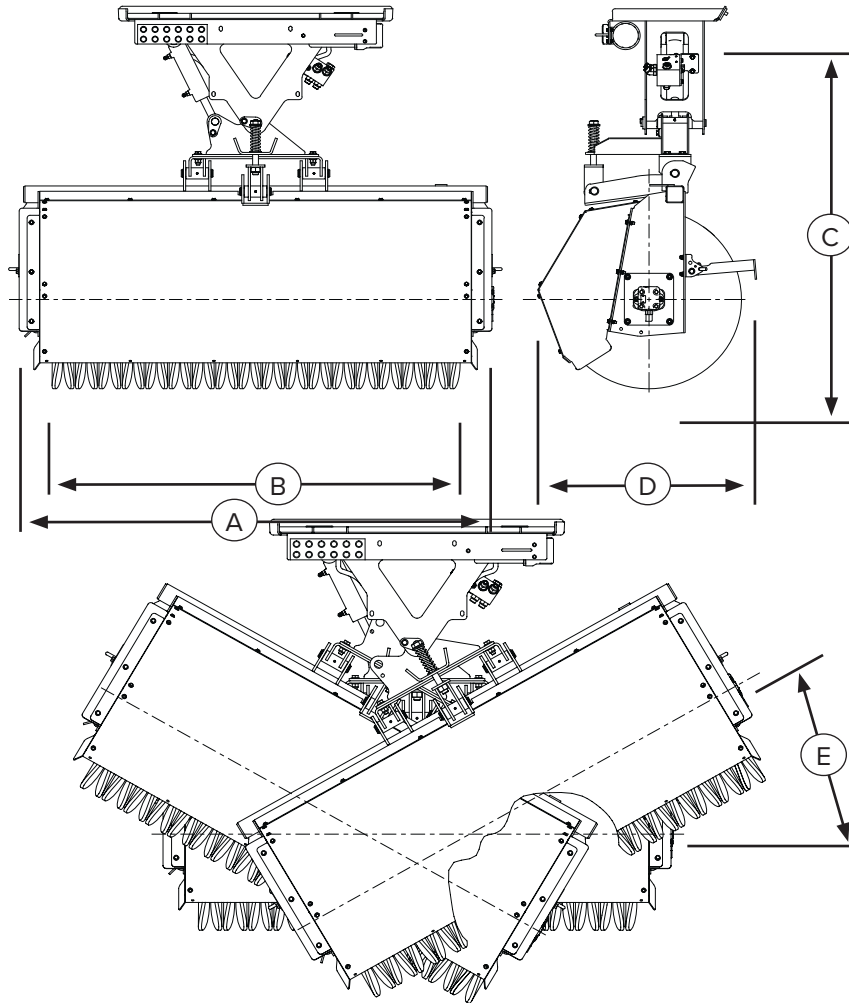

DESCRIPTION	SEVERE DUTY ANGLE BROOM			
	60"	72"	84"	96"
Overall Width (A)	69.5 in 1,765 mm	81.5 in 2,070 mm	93.5 in 2,375 mm	105.5 in 2,680 mm
Brooming Width (B)	60 in 1,524 mm	72 in 1,829 mm	84 in 2,134 mm	96 in 2,438 mm
Overall Depth (C)	68.4 in 1,737 mm			
Overall Height (D)	37.8 in 960 mm			
Pivot Angle - Left & Right (E)	30°			
Weight	995 lbs 451 kg	1,125 lbs 510 kg	1,300 lbs 590 kg	1,450 lbs 658 kg

## 6. Specifications

### 6.2 Performance Specifications

DESCRIPTION	SEVERE DUTY ANGLE BROOM			
	60"	72"	84"	96"
Minimum Flow	15 GPM 56.8 L/min			
Maximum Flow	25 GPM 94.6 L/min			
Minimum Pressure	2,000 PSI 137.9 bar			
Maximum Pressure	3,500 PSI 241.3 bar			
Wafer Diameter (OD)	32 in 813 mm			
Optional Water Kit Weight (Empty)	89 lbs 40 kg			
Optional Water Kit Capacity	25 Gal 95 L			
Optional Front Cover Weight	43 lbs 20 kg	49 lbs 22 kg	56 lbs 25 kg	63 lbs 29 kg

## 6. Specifications

### 6.3 Torque Specifications

#### Standard Hardware and Lock Nuts

BOLT TYPE	SAE GRADE 5		SAE GRADE 8		LOCK NUTS			
	Nominal Size	Plated or Unplated Silver	Plated W/ ZnCr Gold	Plated or Unplated Silver	Plated W/ ZnCr Gold	Plated or Unplated Silver	Plated W/ ZnCr Gold	W/ Grade 5 Bolt
1/4	55 in / lb (6.2 N•m)	72 in / lb (8.1 N•m)	86 in / lb (9.7 N•m)	112 in / lb (12.6 N•m)	121 in / lb (13.6 N•m)	157 in / lb (17.7 N•m)	61 in / lb (6.9 N•m)	86 in / lb (9.8 N•m)
5/16	115 in / lb (13 N•m)	149 in / lb (17 N•m)	178 in / lb (20 N•m)	229 in / lb (26 N•m)	250 in / lb (28 N•m)	325 in / lb (37 N•m)	125 in / lb (14 N•m)	176 in / lb (20 N•m)
3/8	17 ft / lb (23 N•m)	22 ft / lb (30 N•m)	26 ft / lb (35 N•m)	34 ft / lb (46 N•m)	37 ft / lb (50 N•m)	48 ft / lb (65 N•m)	19 ft / lb (26 N•m)	26 ft / lb (35 N•m)
7/16	27 ft / lb (37 N•m)	35 ft / lb (47 N•m)	42 ft / lb (57 N•m)	54 ft / lb (73 N•m)	59 ft / lb (80 N•m)	77 ft / lb (104 N•m)	30 ft / lb (41 N•m)	42 ft / lb (57 N•m)
1/2	42 ft / lb (57 N•m)	54 ft / lb (73 N•m)	64 ft / lb (87 N•m)	83 ft / lb (113 N•m)	91 ft / lb (123 N•m)	117 ft / lb (159 N•m)	45 ft / lb (61 N•m)	64 ft / lb (88 N•m)
9/16	60 ft / lb (81 N•m)	77 ft / lb (104 N•m)	92 ft / lb (125 N•m)	120 ft / lb (163 N•m)	130 ft / lb (176 N•m)	169 ft / lb (229 N•m)	65 ft / lb (88 N•m)	92 ft / lb (125 N•m)
5/8	83 ft / lb (112 N•m)	107 ft / lb (145 N•m)	128 ft / lb (174 N•m)	165 ft / lb (224 N•m)	180 ft / lb (244 N•m)	233 ft / lb (316 N•m)	90 ft / lb (122 N•m)	127 ft / lb (172 N•m)
3/4	146 ft / lb (198 N•m)	189 ft / lb (256 N•m)	226 ft / lb (306 N•m)	293 ft / lb (397 N•m)	319 ft / lb (432 N•m)	413 ft / lb (560 N•m)	160 ft / lb (217 N•m)	226 ft / lb (306 N•m)
7/8	142 ft / lb (193 N•m)	183 ft / lb (248 N•m)	365 ft / lb (495 N•m)	473 ft / lb (641 N•m)	515 ft / lb (698 N•m)	667 ft / lb (904 N•m)	258 ft / lb (350 N•m)	364 ft / lb (494 N•m)
1	213 ft / lb (289 N•m)	275 ft / lb (373 N•m)	547 ft / lb (742 N•m)	708 ft / lb (960 N•m)	773 ft / lb (1048 N•m)	1000 ft / lb (1356 N•m)	386 ft / lb (523 N•m)	545 ft / lb (739 N•m)

---

**This page intentionally  
left blank**



## Warranty

### MANUFACTURER'S LIMITED WARRANTY

BLUE DIAMOND® ATTACHMENTS, a manufacturer of quality attachments, warrants new BLUE DIAMOND® ATTACHMENTS products and/or attachments at the time of delivery to the original purchaser, to be free from defects in material and workmanship when properly set up and operated in accordance with the recommendations set forth by BLUE DIAMOND® ATTACHMENTS, LLC.

BLUE DIAMOND® ATTACHMENTS liability for any defect with respect to accepted goods shall be limited to repairing the goods at a BLUE DIAMOND® ATTACHMENTS designated location or at an authorized dealer location, or replacing them, as BLUE DIAMOND® ATTACHMENTS shall elect. The above shall be in accordance with BLUE DIAMOND® ATTACHMENTS warranty adjustment policies. BLUE DIAMOND® ATTACHMENTS obligation shall terminate twelve (12) months for the Severe Duty Series 2 Angle Broom after the delivery of the goods to original purchaser.

This warranty shall not apply to any machine or attachment which shall have been repaired or altered outside the BLUE DIAMOND® ATTACHMENTS factory or authorized BLUE DIAMOND® ATTACHMENTS dealership or in any way so as in BLUE DIAMOND® ATTACHMENTS judgment, to affect its stability or reliability, nor which has been subject to misuse, negligence or accident beyond the company recommended machine rated capacity.

### WARRANTY CLAIM

To submit a warranty claim, a claim must be filed with BLUE DIAMOND® ATTACHMENTS before work is performed. The BLUE DIAMOND® PRODUCT SUPPORT TEAM will advise repairs and applicable parts exchanges. Tampering with the failed part may void the warranty. This warranty does not include freight or delivery charges incurred when returning machinery for servicing. Dealer mileage, service calls, and pickup/delivery charges are the customers' responsibility.

### EXCLUSIONS OF WARRANTY

Except as otherwise expressly stated herein, BLUE DIAMOND® ATTACHMENTS makes no representation or warranty of any kind, expressed or implied, AND MAKES NO WARRANTY OF MERCHANTABILITY IN RESPECT TO ITS MACHINERY AND/OR ATTACHMENTS ARE FIT FOR ANY PARTICULAR PURPOSE. BLUE DIAMOND® ATTACHMENTS shall not be liable for incidental or consequential damages for any breach or warranty, including but not limited to inconvenience, rental of replacement equipment, loss of profits or other commercial loss. Upon purchase, the buyer assumes all liability for all personal injury and property resulting from the handling, possession, or use of the goods by the buyer.

No agent, employee, or representative of BLUE DIAMOND® ATTACHMENTS has any authority to bind BLUE DIAMOND® ATTACHMENTS to any affirmation, representation, or warranty concerning its machinery and/or attachments except as specifically set forth herein.

This warranty policy supersedes any previous documents.

**NOTE:** Blue Diamond® Attachments is a trademark of BLUE DIAMOND® ATTACHMENTS



**QUALITY | DEPENDABILITY | INTEGRITY**

Blue Diamond® Attachments  
4512 Anderson Road, Knoxville, TN 37918  
888-376-7027