

BOX BLADE TRACTOR ATTACHMENT

426010, 426015, 426110, 426115, 426120



Operator's Manual



Read the Operator's Manual entirely. When you see this symbol, the subsequent instructions and warnings are serious follow without exception. Your life and the lives of others depend on it!

IMPORTANT SAFETY INFORMATION

THESE ARE STANDARD PRACTICES THAT MAY NOT APPLY TO THE PRODUCTS DESCRIBED IN THIS MANUAL.

SAFETY AT ALL TIMES

Thoroughly read and understand the instructions given in this manual before operation. Refer to the "Safety Label" section, read all instructions noted on them. Do not allow anyone to operate this equipment who has not thoroughly read and comprehended this manual. Do not allow anyone who has not adequately trained in the safe operation of the equipment.

- Operator should be familiar with all functions of the unit.
- Operate implement from the driver's seat only.
- Make sure all guards and shields are in place and secured before operating the implement.
- Do not leave tractor or implement unattended with engine running.
- Dismounting from a moving tractor could cause serious injury or death.
- Do not stand between tractor and implement during hitching.
- Keep hands, feet, and clothing away from power-driven parts.
- Wear snug fitting clothing to avoid entanglement with moving parts.
- Watch out for wires, trees, etc., when raising implement. Make sure all persons are clear of working area.
- Turning tractor too tight may cause implement to ride up on wheels. This could result in injury or equipment damage.



LOOK FOR THE SAFETY ALERT SYMBOL

The **SAFETY ALERT SYMBOL** indicates a potential hazard to personal safety, and individuals must take safety precautions. When you see this symbol, be alert and carefully read the message that follows it. In addition to the design and configuration of equipment, hazard control and accident prevention depend on the awareness, concern, prudence, and proper training of personnel involved in the operation, transport, maintenance, and storage.

BE AWARE OF SAFETY ALERT WORDS

DANGER: Indicates an imminently hazardous situation which, if not avoided, will result in death or serious injury. This signal word is limited to the most extreme situations, typically for machine components that, for functional purpose, cannot be guarded.

WARNING: Indicates a potentially hazardous situation which, if not avoided, could result in death or serious injury, and includes hazards that are exposed when guards are removed. It may also be used to alert against unsafe practices.

CAUTION: Indicates a potentially hazardous situation which, if not avoided, may result in minor or moderate injury. It may also be used to alert against unsafe practices.

For your protection

Thoroughly read and understand the “safety label” section, read all instructions noted on them.

Shutdown and storage

- Lower machine to ground, put tractor in park, turn off engine, and remove the ignition key.
- Detach and store implements in an area where children normally do not play.
- Secure implement by using blocks and supports.

Use safety lights and devices

- Slow moving tractors, self-propelled equipment, and towed implements can create a hazard when driven on public roads. They are difficult to see, especially at night.
- Flashing warning lights and turn signals are recommended whenever driving on public roads.

Transport machinery safely

- Comply with state and local laws.
- Maximum transport speed for implement is 20 mph. Do not exceed. Never travel at a speed which does not allow adequate control of steering and stopping. Some rough terrain requires a slower speed.
- Sudden braking can cause a towed load to swerve and upset. Reduce speed if towed load is not equipped with brakes.
- Do not tow a load that is more than double the weight of tractor.

Keep riders off machinery

- Riders obstruct of operator’s view, they could be struck by foreign objects or thrown from the machine. Never allow children to operate equipment. Practice safe maintenance
- Understand procedure before doing work. Use proper tools and equipment.
- Work in a clean dry area.
- Lower the implement to the ground, put tractor in park, turn off engine, and remove key before performing maintenance.
- Allow implement to cool completely.
- Do not grease or oil implement while it is operation.
- Inspect all parts. Make sure parts are in good condition and installed properly.
- Remove buildup of grease, oil, or debris.

- Remove all tools and unused parts from implement before operation.

Prepare for emergencies

- Be prepared if a fire starts.
- Keep a first aid kit and fire extinguisher handy.
- Keep emergency numbers for doctor, ambulance, hospital, and fire department near phone.

Wear protective equipment

- Protective clothing and equipment should be worn.
- Wear clothing and equipment appropriate for the job. Avoid loose fitting clothing.
- Prolonged exposure to loud noise can cause hearing impairment or hearing loss. Wear suitable hearing protection such as earmuffs or earplugs.
- Operating equipment safely requires the full attention of the operator.
- Avoid wearing radio headphones while operating machinery.

Avoid high pressure fluids hazard

- Escaping fluid under pressure can penetrate the skin causing serious injury.
- Avoid the hazard by relieving pressure before disconnecting hydraulic lines.
- Use a piece of paper or cardboard, not body parts, to check for suspected leaks.
- Wear protective gloves and safety glasses or goggles when working with hydraulic systems.
- If an accident occurs, see a doctor immediately. Any fluid injected into the skin must be treated within a few hours or gangrene may result.

SAFETY LABELS

The Box Blade comes equipped with all safety labels in place. These are designed to help you safely operate your implement. Read and follow their directions.

1. Keep all safety labels clean and legible.
2. Replace all damaged or missing labels. To order new labels go to your nearest dealer.
3. Some new equipment installed during repair requires safety labels to be affixed to the replaced component as specified by Blue Diamond. When ordering new components make sure the correct safety labels are included in the request.
4. Refer to this section for proper label placement.

To install new labels:

- a. Clean the area the label is to be placed.
- b. Spray soapy water on the surface where the label is to be placed.
- c. Peel backing from label. Press firmly onto the surface.
- d. Squeeze out air bubbles with the edge of a credit card.

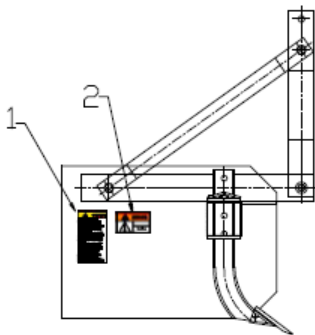

INTRODUCTION

APPLICATION

Box Blades are designed for Category 1 - three-point hitch or Quick-Hitch System mounting. These Fixed Bar Box blades are ideal for ripping, leveling, finish grading, and backfilling applications at feedlots, outdoor arenas, building sites, and maintenance operations on farm and ranch lanes or roadways.

USING THIS MANUAL

- This Operator's Manual is designed to help familiarize you with safety, assembly, operation, adjustments, troubleshooting, and maintenance. Read this manual and follow the recommendations to help ensure safe and efficient operation.
- The information contained within this manual was current at the time of printing. Some parts may change slightly to assure you of the best performance.

TERMINOLOGY

"Right" or "Left" as used in this manual is determined by facing the direction the machine will operate while in use unless otherwise stated.

DEFINITIONS

Note: A special point of information that the operator must be aware of before continuing.
Important: A special point of information related to its preceding topic. The intention is that this information should be read and noted before continuing.

SECTION 1: ASSEMBLY AND SET-UP

TRACTOR REQUIREMENTS

The Box Blades are designed with a 3-point category I hitch.

ASSEMBLY

Refer to the parts illustration.

SECTION 2: ADJUSTMENTS

SHANK SETTINGS

Shank settings are based on the vertical distance from the bottom edge of Box Blade side plates to the bottom of the shank tips.

 CAUTION Adjust the shank setting after the scraper has been properly attached to a tractor and supported with blocks to prevent injury!

 CAUTION
Keep feet clear when lowering the shanks!

LEVELING AND PITCH ADJUSTMENT

Check for levelness by parking the tractor on level surface and placing a level on the front shank tube. Level Box Blade from left to right by adjusting one of the tractor's 3-point lower arms up or down. Rotate level 90 degrees on the shank tube and then adjust the tractor's top center link until the shank tubes is level from front to back.

SECTION 3: OPERATING PROCEDURES

OPERATING CHECK LIST:

Hazard control and accident prevention are dependent upon the awareness, concern, prudence, and proper training involved in the operation, transport, maintenance, and storage of the machine. Therefore, it is absolutely essential that no one operates the Box Blade without first having read, fully understood, and become totally familiar with the Operator's Manual. Make sure the operator has paid particular attention to safety information and other sections of this manual.

 CAUTION It is the operator's responsibility not to allow anyone near the Box Blade during its operation.

 CAUTION Be sure that you are not working over any underground wiring, pipes, or other obstructions. If there is any doubt, call your public service agency.

 CAUTION Always keep your feet and legs out from under the shanks when adjusting the height of the shanks. It is possible the shanks could slip and fall causing injury to your feet and/or legs.

- Follow all directions on the safety labels.
- Do not allow anyone to operate this Box Blade who has not been properly trained in its safe operation. Do not let anyone under the age of 16 operate the Box Blade.
- Use the Box Blade for its intended purpose only.
- Never carry passengers or use the Box Blade as a wagon to carry things.
- Never use the Box Blade to pull or tow other equipment or objects.

- Make sure all safety labels are in their proper location and in good condition before operation.
- Never work under the unit without properly blocking the unit up.
- Before working the soil contact your local utility services, so that they mark the location of any underground utility services in the area. Be sure to ask how close you can work to the marks or flags they positioned.
- All nuts, bolts, screws, and fasteners should be checked periodically for tightness.
- Do not alter the Box Blade in a way which will adversely affect its performance or reliability or use the Box Blade for a purpose for which it was not designed.

TRANSPORTING

When traveling on public roads at night or during the day, use accessory lights and devices for adequate warning to operators of other vehicles. Comply with all federal, state, and local laws.

- Be sure to reduce tractor ground speed when turning; and leave enough clearance so the Box blade does not contact obstacles such as buildings, trees or fences.
- Select a safe ground travel speed when transporting from one area to another.
- When traveling on roadways, transport in such a way that faster moving vehicles may pass you safely.
- When traveling over rough or hilly terrain, shift tractor to a lower gear.

GENERAL OPERATING INSTRUCTIONS

Once you have familiarized yourself with the operator's manual, completed the operations checklist, and properly attached your Box Blade to your tractor, you are now almost ready to begin work. Box Blades are ideal for ripping, leveling, finish grading, and backfilling applications at feedlots, outdoor arenas, building sites, and maintenance operations on farm and ranch lanes or roadways. Hopefully you have checked out your work site for any buried utility cables, pipelines, or obstacles that you wouldn't to damage or encounter.

A Box Blade's primary purpose is grading and leveling. This function is best done at an approximate 2 to 4mph ground speed. With the ripper shanks raised all the way up, simply lower the Box Blade should immediately begin shaving the soil surface and dirt or aggregate material should begin accumulating in the box. You can transfer this material by dragging it to a nearby location and then raising the scraper to deposit your load. You can also achieve uniform distribution and leveling of scraped material by setting the scraper to shave off high spots allowing accumulated material to flow out under the grader blade in the low spots. Occasionally the ground or surface material will be very hard and will require ripping to loosen the soil profile in order for the scraper blade to be effective. If more aggressive ripping action is desired, lower the shanks by 2" increments at a time. If less aggressive ripping action is desired, raise all of the shanks. Achieving the desired effect will require a little experimentation and experience in your given conditions. Box blades generally perform better in dry to slightly damp soil conditions. The Box blade can also be used for backfilling applications. Simply lower your scraper and back the standard rear facing grader blade into the pile of dirt you are using for backfilling. Continue backfilling and pushing operations until you have successfully completed the task. With a little practice you should become a very good operator and consistently achieve the desired results.

Section 4: MAINTENANCE

MAINTENANCE

Proper servicing and adjustment are the key to the long life of any farm implement. With careful and systematic inspection, you can avoid costly maintenance, time, and repair.

GENERAL

- After using your scraper for several hours, check all bolts to be sure they are tight.
- Replace any worn, damaged, or illegible safety decals by obtaining new decals from dealer.

SHANK TIPS

Shank tips are removable by heating them in the dimpled area on both sides and knocking them off with a blunt punch. New shank tips need to be dimpled with a punch after they are installed.

CUTTING BLADES

The front and rear cutting blades have two cutting edges. Replace the cutting blades when both edges are worn out.

STORAGE

- At the end of the working season or when your Box Blade will not be used for long period, it is good practice to clean off any dirt or grease that may have accumulated on the scraper and any of the moving parts.
- Repaint parts where paint is worn or scratched to prevent rust.
- Replace all damaged or missing decals.
- Store the scraper inside if possible. Inside storage will reduce maintenance and make for a longer life.
- Inspect scraper for loose, damaged, or worn parts and adjust or replace if needed.

SECTION 5: APPENDIX

BOLT TORQUE

The table shown below give correct torque values for various bolts and caps crews. Tighten all bolts to the torques specified unless otherwise noted. Check tightness of bolts periodically, using bolt torque chart as a guide. Replace hardware with the same strength bolt.

ENGLISH TORQUE SPECIFICATIONS

Bolt Diameter	Bolt Torque					
	SAE 2		SAE 5		SAE 8	
	NM	lb-ft	NM	lb-ft	NM	lb-ft
1/4"	8	6	12	9	17	12
5/16"	13	10	25	19	36	27
3/8"	27	20	45	33	63	45
7/16"	41	30	72	53	100	75
1/2"	61	45	110	80	155	115
9/16"	95	60	155	115	200	165
5/8"	128	95	215	160	305	220
3/4"	225	165	390	290	540	400
7/8"	230	170	570	420	880	650

METRIC TORQUE SPECIFICATIONS

Bolt Diameter	Bolt Torque			
	8.8		10.9	
	N.m	lb-ft	N.m	lb-ft
M3	0.5	0.4	1.8	1.3
M4	3	2.2	4.5	3.3
M5	6	4	9	7
M6	10	7	15	11
M8	25	18	35	26
M10	50	37	70	52
M12	90	66	125	92
M14	140	103	200	148
M16	225	166	310	229
M20	435	321	610	450
M24	750	553	1050	744
M30	1495	1103	2100	1550
M36	2600	1917	3675	2710

Torque figures indicated above are valid for non-greased or non-oiled threads and heads otherwise specified. Therefore, do not grease or oil bolts or caps crews unless otherwise specified in this manual. When using locking elements, increase torque values by 5%.

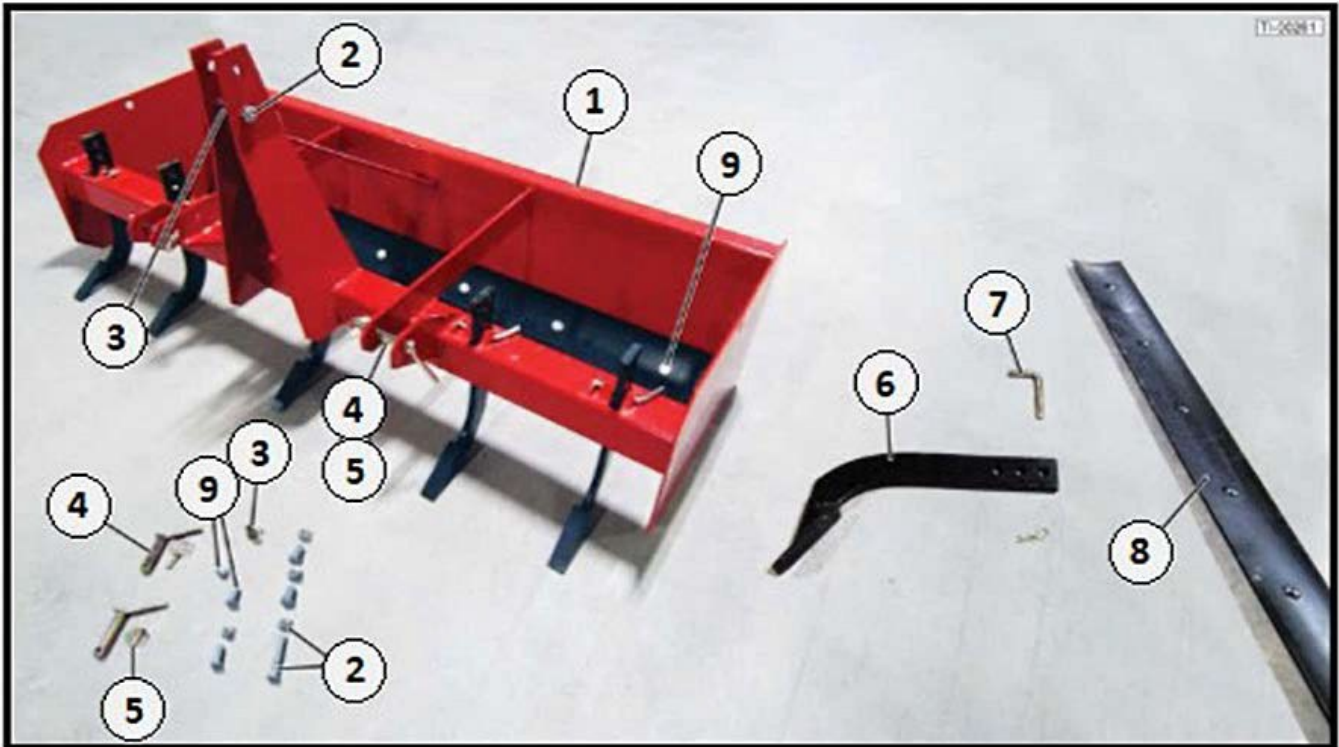

Item	Description	QTY
1	Frame Standard	1
2	Bolt & Locknut Kit 3/4" x 4" - for A-Frame	1
3	Spacer 2 1/4" - for A-Frame	1
4	Lift Pin CAT-I - Handle Type	2
5	Lynch Pin 3/8"	2
6	Box Shank with Point	A/R
7	Pin, L Type - for Box Shank	A/R
8	Cutting Edge 3/8" x 6" x 47 3/4"	2
	Cutting Edge 3/8" x 6" x 59 3/4"	
	Cutting Edge 3/8" x 6" x 71 3/4"	
	Cutting Edge 3/8" x 6" x 83 3/4"	
	Cutting Edge 3/8" x 6" x 95 3/4"	
9	Plow Bolt & Nut Kit 5/8" x 1 1/2"	A/R

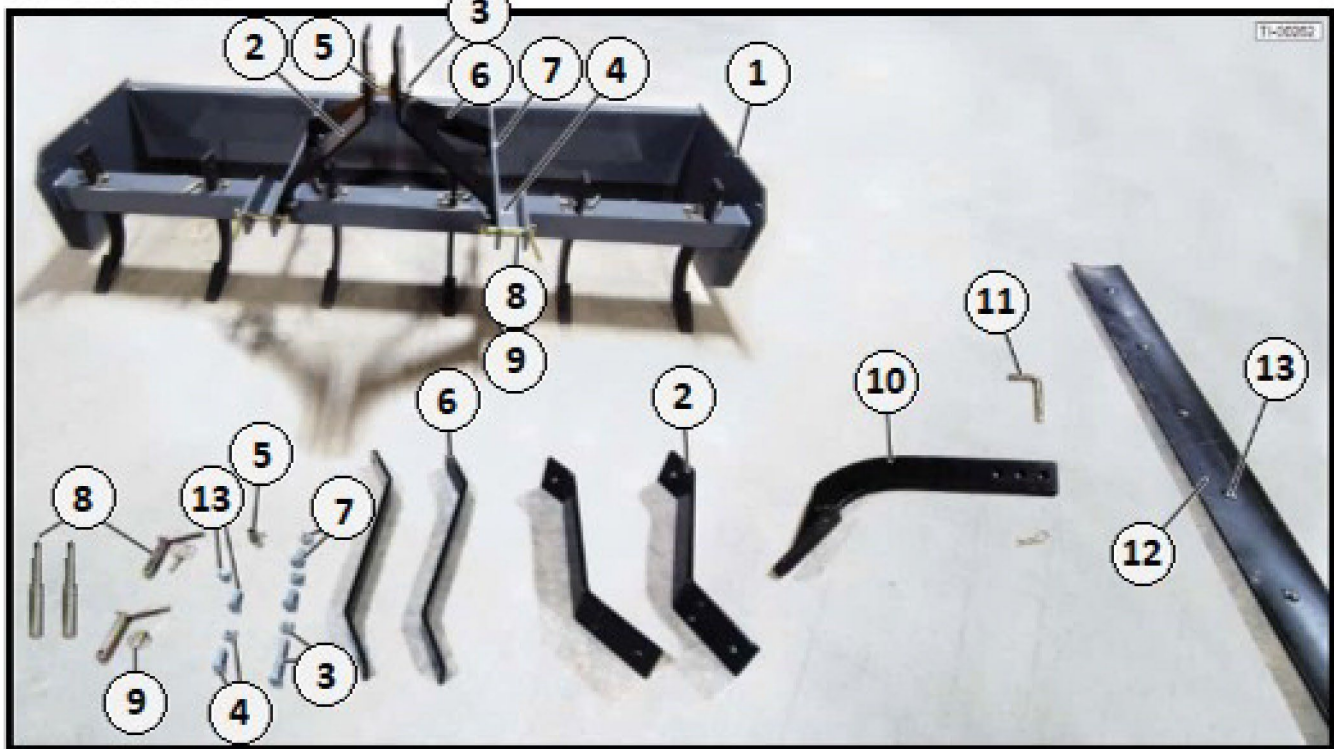

Item	Description	QTY
1	Frame Standard	1
2	A-Frame, Heavy Duty 1/2" x 4" x 26"	2
3	Bolt & Locknut Kit 5/8" x 4 1/2" - for Top A-Frame	1
4	Bolt & Locknut Kit 5/8" x 2" - for Bottom A-Frame	1
5	Spacer 2" - for A-Frame	1
6	Back Brace 1/2" x 2 1/2" x 29 1/2"	2
7	Bolt & Locknut Kit 5/8" x 2" - for Back Brace	1
8	Lift Pin CAT-I Handle Type	2
	Lift Pin CAT-II Stepdown Pin	
9	Lynch Pin 3/8"	2
10	Box Shank with Point	A/R
11	Pin, L Type - for Box Shank	A/R
12	Cutting Edge 3/8" x 6" x 71 3/4"	2
	Cutting Edge 3/8" x 6" x 83 3/4"	
	Cutting Edge 3/8" x 6" x 95 3/4"	
13	Plow Bolt & Nut Kit 5/8" x 1 1/2"	A/R

ACKNOWLEDGEMENT OF RISK AND RELEASE OF LIABILITY

The use of any equipment, including this one, involves the potential risk of injury. Apart from any warranty claim that might be presented for a claimed defect in material or workmanship of the product, you accept and assume full responsibility for any and all injuries, damages (both economic and non-economic), and losses of any type, which may occur, and you fully and forever release and discharge Blue Diamond, its insurers, employees, officers, directors, associates, and agents from any and all claims, demands, damages, rights of action, or causes of action, present or future, whether the same be known or unknown, anticipated, or unanticipated, resulting from or arising out of the use of said equipment.

This equipment must be used with care by capable and competent individuals under supervision, if necessary.

WARNING



Do not overfill! Mower should be level when checking oil in gear box.



some activities might be able to cause electric shock



Sharp objects may be involved.
Use protective cover during maintenance.



Warranty

MANUFACTURER'S LIMITED WARRANTY

BLUE DIAMOND® ATTACHMENTS, a manufacturer of quality attachments, warrants new BLUE DIAMOND® ATTACHMENTS products and/or attachments at the time of delivery to the original purchaser, to be free from defects in material and workmanship when properly set up and operated in accordance with the recommendations set forth by BLUE DIAMOND® ATTACHMENTS, LLC.

BLUE DIAMOND® ATTACHMENTS liability for any defect with respect to accepted goods shall be limited to repairing the goods at a BLUE DIAMOND® ATTACHMENTS designated location or at an authorized dealer location, or replacing them, as BLUE DIAMOND® ATTACHMENTS shall elect. The above shall be in accordance with BLUE DIAMOND® ATTACHMENTS warranty adjustment policies. BLUE DIAMOND® ATTACHMENTS obligation shall terminate twelve (12) months for the Heavy Duty Excavator Drum Mulcher after the delivery of the goods to original purchaser.

This warranty shall not apply to any machine or attachment which shall have been repaired or altered outside the BLUE DIAMOND® ATTACHMENTS factory or authorized BLUE DIAMOND® ATTACHMENTS dealership or in any way so as in BLUE DIAMOND® ATTACHMENTS judgment, to affect its stability or reliability, nor which has been subject to misuse, negligence or accident beyond the company recommended machine rated capacity.

WARRANTY CLAIM

To submit a warranty claim, a claim must be filed with BLUE DIAMOND® ATTACHMENTS before work is performed. The BLUE DIAMOND® PRODUCT SUPPORT TEAM will advise repairs and applicable parts exchanges. Tampering with the failed part may void the warranty. This warranty does not include freight or delivery charges incurred when returning machinery for servicing. Dealer mileage, service calls, and pickup/delivery charges are the customers' responsibility.

EXCLUSIONS OF WARRANTY

Except as otherwise expressly stated herein, BLUE DIAMOND® ATTACHMENTS makes no representation or warranty of any kind, expressed or implied, AND MAKES NO WARRANTY OF MERCHANTABILITY IN RESPECT TO ITS MACHINERY AND/OR ATTACHMENTS ARE FIT FOR ANY PARTICULAR PURPOSE. BLUE DIAMOND® ATTACHMENTS shall not be liable for incidental or consequential damages for any breach or warranty, including but not limited to inconvenience, rental of replacement equipment, loss of profits or other commercial loss. Upon purchase, the buyer assumes all liability for all personal injury and property resulting from the handling, possession, or use of the goods by the buyer.

No agent, employee, or representative of BLUE DIAMOND® ATTACHMENTS has any authority to bind BLUE DIAMOND® ATTACHMENTS to any affirmation, representation, or warranty concerning its machinery and/or attachments except as specifically set forth herein.

This warranty policy supersedes any previous documents.

NOTE: Blue Diamond® Attachments is a trademark of BLUE DIAMOND® ATTACHMENTS



QUALITY | DEPENDABILITY | INTEGRITY

Blue Diamond® Attachments
4512 Anderson Road, Knoxville, TN 37918
888-376-7027