

Initial Setup Instructions

Heavy Duty Excavator Drum Mulcher

TOOLS NEEDED	PURPOSE
Adjustable Wrenches	Hose Connections
Laser Tachometer and Reflective Tape	Speed Measurement
19mm Deep Socket	Motor Adjustment
5mm Allen Key	
8 mm Allen Key	Access Plates



Read and follow completely before operating or using the mulcher in any capacity.

Hydraulic Connections

Hydraulic Connections

P: Pressure 3/4" (#12) Male JIC

R: Return 3/4" (#12) Male JIC

D: Drain 5/8" (#10) Male JIC

Greasing Points

R: Rotor

E: Direct Drive

Hose Connection

1. Connect the case drain hose
2. Connect the return hose
3. Connect the pressure hose

NOTE: Disconnect in the reverse order.



Figure 1

Adjust Rotor Speed

The displacement of the motor may need adjusted to match the mulcher to the host machine.

The motor displacement is adjustable between 26cc and 45cc. The configuration from the factory is at maximum displacement (45cc).

Measure Rotor Speed

1. Remove the front cover to access the rotor pulley.



Figure 2

2. Apply reflective tape to the rotor pulley (Item 1 Figure 2).
3. Engage the rotor. Use a tachometer to measure the speed. The rotor speed should be between 2200 – 2800 rpm. If the rotor speed is not between the stated range, adjust the displacement.

Adjust Displacement



WARNING



Disengage the hydraulics and wait for all moving parts to stop before performing any adjustments. Place the mulcher on a firm, level surface before performing any maintenance procedures.

1. Remove the access cover (Item 1 Figure 3) to access the motor.



Figure 3

2. Remove the hex cap (Item 1 Figures 4 and 5) on the bottom of the motor to access the adjustment screw (Item 2 Figure 4).
3. Loosen the jam nut.
4. Turn the screw to adjust the displacement.

DIRECTION	DISPLACEMENT	ROTOR SPEED
Clockwise	Increase	Decrease
Counterclockwise	Decrease	Increase

5. When the rotor speed is within the 2200 – 2800 rpm range, tighten the jam nut, reinstall the hex cap, and replace the access cover.

Relief Valve Pressure

The relief valve (Item 2 Figure 5) pressure is preset at 4050 PSI (280 bar).

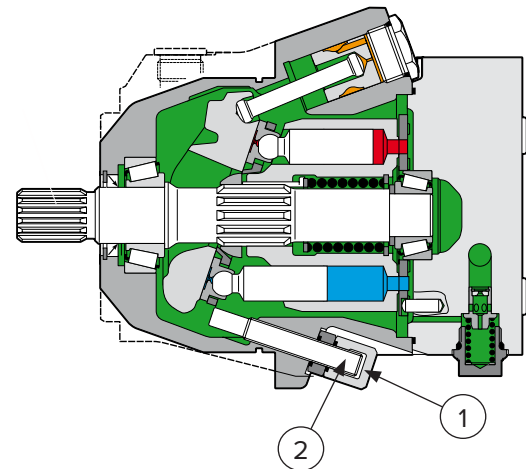

Figure 4

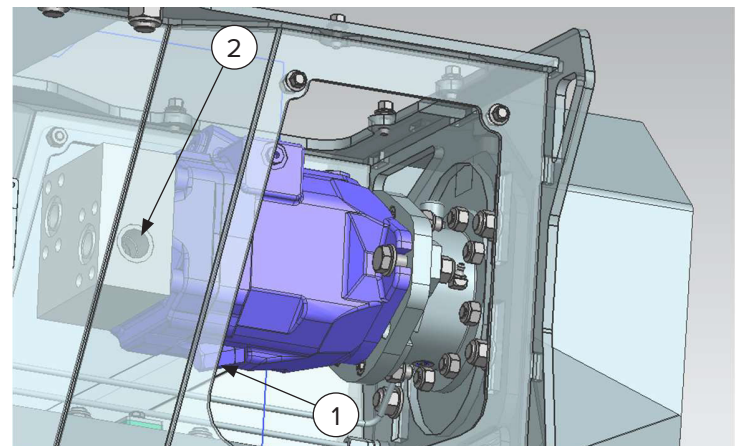

Figure 5