

SNOW BLADE AUTO WING

Operation and Maintenance Manual



Register your
WARRANTY
within 30 days
of purchase



BD-092

888-376-7027 | BlueDiamondAttachments.com

Owner Information

Thank you for your decision to purchase a Blue Diamond Snow Blade Auto Wing. To ensure maximum performance of your equipment, it is mandatory that you thoroughly study the Operator's Manual and follow the recommendations. Proper operation and maintenance are essential to maximize equipment life and prevent personal injury.

Operate and maintain this equipment in a safe manner and in accordance with all applicable local, state, and federal codes, regulations and /or laws. Follow all on-product labeling and instructions.

Make sure that all personnel have read this Operator's Manual and thoroughly understand safe and correct operating, installation and maintenance procedures.

Blue Diamond is continually working to improve its products. Blue Diamond reserves the right to make any improvements or changes as deemed practical and possible without incurring any responsibility or obligation to make any changes or additions to equipment sold previously.

Although great care has been taken to ensure the accuracy of this publication, Blue Diamond makes no warranty or guarantee of any kind, written or expressed, implied or otherwise with regard to the information contained within this manual. Blue Diamond assumes no responsibility for any errors that may appear in this manual and shall not be liable under any circumstances for incidental, consequential or punitive damages in connection with, or arising from the use of this manual.

Keep this manual available for frequent reference. All new operators or owners must review the manual before using the equipment and annually thereafter. Contact your Blue Diamond Attachments Dealer for assistance, information, or additional copies of the manual. Contact www.bluediamondattachments.com or call 888-376-7027 for a complete list of dealers in your area.

Serial Number Location

Please record attachment information in the space provided for future reference.

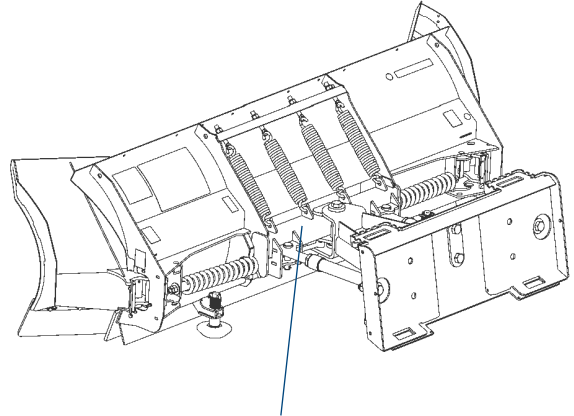

Located at the back of the plow

Model Number: _____

Serial Number: _____

Dealer Name: _____

Dealer Number: _____

Date of Purchase: _____

The serial number plate (is located on right side, just forward of the attachment mounting plate.

Always use your serial number when requesting information or when ordering parts.

NOTE: The directions left, right, front and rear, as mentioned throughout this manual, are as viewed from the operator's position.

Table of Contents

PREFACE	6	MAINTENANCE	19
SAFETY INFORMATION	7	Preseason Check.....	19
Snow Blade WEIGHTS AND VEHICLE		Postseason Maintenance.....	19
APPLICATION INFORMATION	10	Maintenance and Adjustment	20
GETTING TO KNOW YOUR snow blade	11	Hydraulic Hose and Fitting Replacement	21
Hydraulics Guide.....	11	Vehicle	22
Oscillation	11	Recycle	22
ATTACHING & DETACHING INSTRUCTIONS	13	Blade finish	22
OPERATING YOUR snow blade	14	Tools	22
Blade Positions – Auto Wing.....	14	Troubleshooting	22
Disc Shoe Adjustment.....	15	TECHNICAL SPECIFICATIONS	23
Transporting snow blade	16		
Driving and Plowing on Snow and Ice	16		
Plowing Snow	17		
Parking with snow blade Attached	18		
Towing a Disabled or Stuck Vehicle.....	18		

2. SAFETY

2.1 SAFETY DEFINITIONS

⚠️ WARNING







Indicates a potentially hazardous situation, that if not avoided, could result in death or serious personal injury.

⚠️ CAUTION

Indicates a potentially hazardous situation that, if not avoided, may result in minor or moderate injury. It may also be used to alert against unsafe practices.

NOTE: Indicates a situation or action that can lead to damage to your snow blade and vehicle or other property. Other useful information can also be described.

Warning/Caution Label

⚠️ WARNING	
	Blade could drop unexpectedly, crushing or trapping limbs. Lower blade when vehicle is parked.
	Overloading could negatively affect vehicle handling. To avoid serious injury or death, do not exceed GVWR or GAWR including blade and ballast.
⚠️ CAUTION	
	Read Owner's Manual before operating or servicing snowplow.
	Transport speed should not exceed 45 mph (72 km/h). Further reduce speed under adverse travel conditions.
	Plowing speed should not exceed 10 mph (16 km/h).
	See your sales outlet/website for specific vehicle application recommendations.

Multiple Pinch Points Label



⚠️ WARNING	
	
Multiple Pinch Points	

WARNING/CAUTION & INSTRUCTION LABELS

Become familiar with and inform users about the warning and instruction labels on the back of the blade.

NOTE: If labels are missing or cannot be read, see your sales outlet.

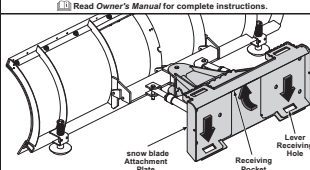
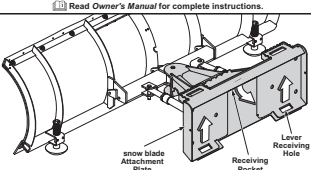
Instruction Label

Attach	Detach
	
⚠️ WARNING Keep fingers away from snow blade and skid steer pinch point.	 Follow skid steer labeling and Owner's Manual instructions.
<ul style="list-style-type: none"> Position the skid steer close to the snow blade and align the mount points on the skid steer plate with the snow blade attachment plate. Tilt the skid steer plate forward and position the top edge of the plate under the receiving pocket on the top edge of the snow blade attachment plate. Slowly raise the arms on the skid steer and tilt the skid steer plate toward the cab until the snow blade attachment plate is flush with the skid steer plate. Turn the engine OFF. Engage both locking levers on the skid steer by rotating each handle 90° into a horizontal position. The skid steer locking levers shall insert into the snow blade lever receiving holes. Attach all hydraulic hoses on the snow blade to the auxiliary hydraulic connections located on the skid steer. On some skid steer models, it may be necessary to initiate an auxiliary hydraulic switch on the skid steer prior to operating the snow blade. 	<ul style="list-style-type: none"> Lower the snow blade on a flat, level surface and turn the engine OFF. Disconnect all hydraulic hoses on the snow blade from the auxiliary hydraulic connections located on the skid steer. Disengage both locking levers on the skid steer by rotating each handle 90° into a vertical position. The skid steer locking levers shall withdraw from the snow blade lever receiving holes. Turn the engine ON. Slowly lower the arms on the skid steer and tilt the skid steer plate forward away from the cab until the top edge of the skid steer plate clears the receiving pocket on the top edge of the snow blade attachment plate. Back the skid steer away slowly.

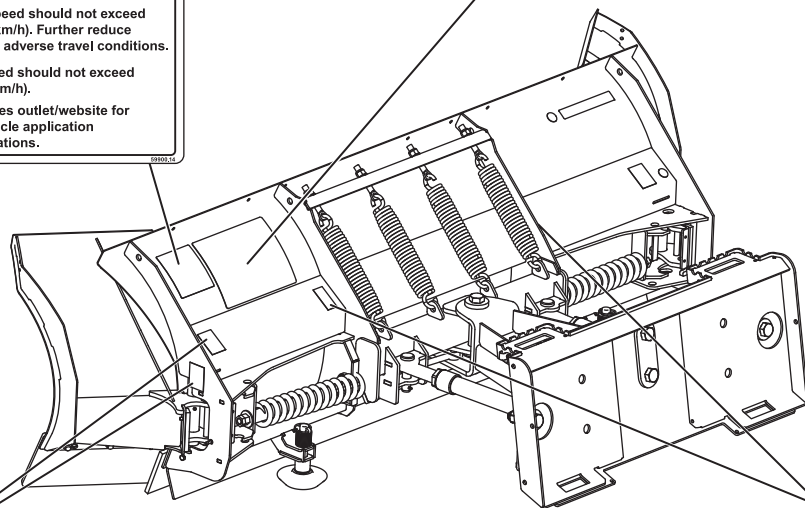

Crush Hazard Label

⚠️ WARNING	
	
Crush hazard	
Keep feet clear	

SAFETY

SAFETY PRECAUTIONS

Owner's Manual before installing, operating, or making adjustments.

⚠ WARNING

Lower the blade when the vehicle is parked. Temperature changes could change hydraulic pressure, causing the blade to drop unexpectedly or damaging hydraulic components. Failure to do this could result in serious personal injury.

⚠ WARNING

The driver shall keep bystanders clear of the blade when it is being raised, lowered, or angled. Do not stand between vehicle and blade or within 8 feet of a moving blade. A moving or falling blade could cause personal injury.

⚠ WARNING



Do not exceed vehicle operative capacity including the blade. See vehicle rating label.

⚠ WARNING

Never stand, work or reach under lift arms or lift cylinders without employing a lift arm stop or stand.

⚠ CAUTION

Read Owner's Manual before operating or servicing snow blade.

⚠ CAUTION

Transport speed should not exceed vehicle manufacturer's recommendations. Further reduce speed under adverse travel conditions.

⚠ CAUTION

Plowing speed should not exceed 10 mph (16 km/h).

SAFETY

HYDRAULIC SAFETY

⚠ WARNING



Hydraulic fluid under pressure can cause skin injection injury. If you are injured by hydraulic fluid, get medical attention immediately.

- Always inspect hydraulic components and hoses before using. Replace any damaged or worn parts immediately.
- If you suspect a hose leak, DO NOT use your hand to locate it. Use a piece of cardboard or wood.

PERSONAL SAFETY

- Remove ignition key and put the vehicle in park or in gear to prevent others from starting the vehicle during installation or service.
- Wear only snug-fitting clothing while working on your vehicle or snow blade.
- Do not wear jewelry or a necktie, and secure long hair.
- Wear safety goggles to protect your eyes from battery acid, gasoline, dirt, and dust.
- Avoid touching hot surfaces such as the engine, radiator, hoses, and exhaust pipes.
- Always have a fire extinguisher rated BC handy, for flammable liquids and electrical fires.

FIRE AND EXPLOSION

Be careful when using gasoline. Do not use gasoline to clean parts. Store only in approved containers away from sources of heat or flame.

⚠ WARNING

Gasoline is highly flammable and gasoline vapor is explosive. Never smoke while working on vehicle. Keep all open flames away from gasoline tank and lines. Wipe up any spilled gasoline immediately.

CELL PHONES

A driver's first responsibility is the safe operation of the vehicle. The most important thing you can do to prevent a crash is to avoid distractions and pay attention to the road. Wait until it is safe to operate Mobile Communication equipment such as cell phones, text messaging devices, pagers or two-way radios.

VENTILATION

⚠ WARNING

Vehicle exhaust contains lethal fumes. Breathing these fumes, even in low concentrations, can cause death. Never operate a vehicle in an enclosed area without venting exhaust to the outside.

BATTERY SAFETY

⚠ CAUTION

Batteries normally produce explosive gases, which can cause personal injury. Therefore, do not allow flames, sparks, or lit tobacco to come near the battery. When charging or working near a battery, always cover your face and protect your eyes, and also provide ventilation.

- **Batteries contain sulfuric acid, which burns skin, eyes, and clothing.**
- **Disconnect the battery before removing or replacing any electrical components.**

NOISE

Airborne noise emission during use is below 70 dB(A) for the snow blade operator.

VIBRATION

Operating snow blade vibration does not exceed 2.5 m/s² to the hand-arm or 0.5 m/s² to the whole body.

WEIGHTS / VEHICLE APPLICATION INFORMATION

BLADE ASSEMBLY WEIGHTS

Size	Blade Assembly	Wt (lb)	Wt (kg)
8'7"	Auto Wing Blade	875	396

VEHICLE APPLICATIONS

⚠ CAUTION See your outlet for specific vehicle application recommendations before installation.
--

Vehicle application recommendations are based on the following:

- The vehicle with the snow blade installed must comply with the vehicle manufacturer's stated gross vehicle and axle weight ratings and the front and rear weight distribution ratio.
- In some cases there may be additional limitations and requirements.
- Installation, modification, and addition of accessories must comply with published recommendations and instructions. Available capacity decreases as the vehicle is loaded with cargo or other equipment or snow blade accessories are installed.
- If there is uncertainty as to whether available capacity exists, the actual vehicle as configured must be weighed.

GETTING TO KNOW YOUR SNOW BLADE

OSCILLATION

Your skid steer now comes equipped with the ability to oscillate 6 degrees. This allows the operator of the vehicle to adjust the down pressure as needed.

HYDRAULICS GUIDE

Hydraulic hose routing information is found on the Hydraulic Hose Port Guide label (shown below) that is located on the underside of the step plate.

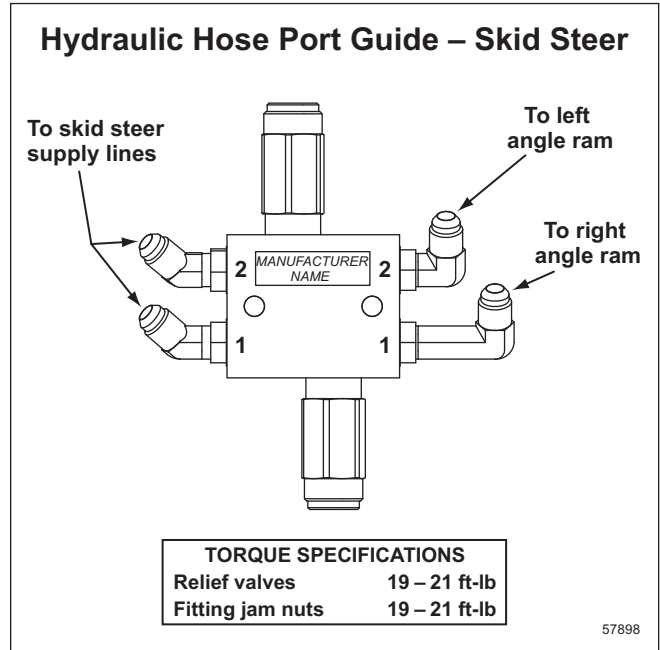

NOTE: The skid steer supply lines use special fittings that restrict the flow entering the block. Do not replace with anything other than approved hydraulic fittings.

ATTACHING & DETACHING INSTRUCTIONS

⚠ WARNING

Keep 8 feet clear of the blade when blade is being raised, lowered or angled. Do not stand between the vehicle and blade or directly in front of blade. If the blade hits or drops on you, you could be seriously injured.

⚠ WARNING

Inspect snow blade components and fasteners for wear or damage whenever mounting or removing the snow blade. Worn or damaged components could allow the snow blade to drop unexpectedly.

Prior to operating your snow blade, review the Attach/Detach Instructions label (shown below) on the back left side of the moldboard.

NOTE: If at any time the Attach/Detach Instructions label or any other label attached to your snow blade becomes illegible, promptly replace it.

Attach	Detach
<p>Read <i>Owner's Manual</i> for complete instructions.</p>	<p>Read <i>Owner's Manual</i> for complete instructions.</p>
<p>⚠ WARNING</p> <p>Keep fingers away from snow blade and skid steer pinch points.</p>	<p>Follow skid steer labeling and <i>Owner's Manual</i> instructions.</p>
<ul style="list-style-type: none"> Position the skid steer close to the snow blade and align the mount points on the skid steer plate with the snow blade attachment plate. Tilt the skid steer plate forward and position the top edge of the plate under the receiving pocket on the top edge of the snow blade attachment plate. Slowly raise the arms on the skid steer and tilt the skid steer plate toward the cab until the snow blade attachment plate is flush with the skid steer plate. Turn the engine OFF. Engage both locking levers on the skid steer by rotating each handle 90° into a horizontal position. The skid steer locking levers shall insert into the snow blade lever receiving holes. Attach all hydraulic hoses on the snow blade to the auxiliary hydraulic connections located on the skid steer. On some skid steer models, it may be necessary to initiate an auxiliary hydraulic switch on the skid steer prior to operating the snow blade. 	<ul style="list-style-type: none"> Lower the snow blade on a flat, level surface and turn the engine OFF. Disconnect all hydraulic hoses on the snow blade from the auxiliary hydraulic connections located on the skid steer. Disengage both locking levers on the skid steer by rotating each handle 90° into a vertical position. The skid steer locking levers shall withdraw from the snow blade lever receiving holes. Turn the engine ON. Slowly lower the arms on the skid steer and tilt the skid steer plate forward away from the cab until the top edge of the skid steer plate clears the receiving pocket on the top edge of the snow blade attachment plate. Back the skid steer away slowly.
US Patents 7,134,227; 8,850,724; and other patents pending.	31541-00

OPERATING YOUR SNOW BLADE

BLADE POSITIONS – AUTO WING

Your Auto Wing snow blade is the most advanced and versatile snow blade on the market. The easy-to-use controls allow you to automatically adjust the snow blade blade and wings into an infinitenumber of plowing positions. Review the illustrations below to determine the best position for your plowing needs.

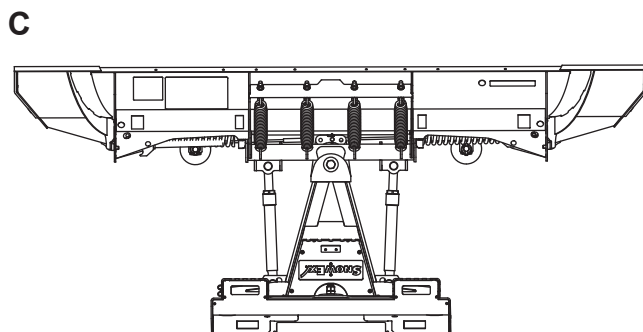
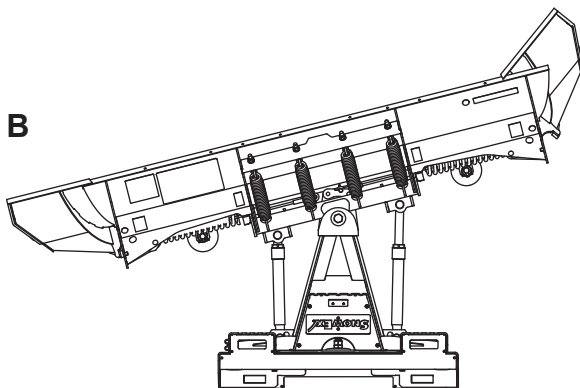
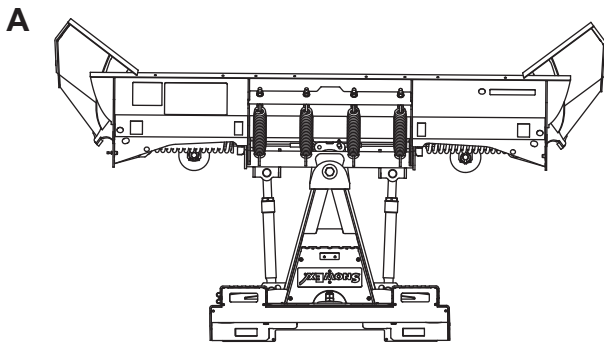

⚠ WARNING

Never use the snow blade attachment to carry people, as a man lift, or as a work platform.

⚠ WARNING

When plowing with down pressure, do not cause the front wheels on the skid steer/ tractor to raise above ground.

A. Scoop Blade Position

- Primary position for transporting snow
- For use in initial clearing with decent visibility, transporting large volumes of snow, final clean-up
- *Ideal application: roadway intersections*

B. Windrow Blade Position

- Primary position for accelerated angled plowing
- For use in directional plowing, cornering, diverting snow away from objects or buildings
- *Ideal application: plowing adjacent to buildings, driveway/road intersections*

C. Straight Blade Option

- Wings may be pinned in position to operate as a straight blade. Primary position for clearing large surfaces
- For use in light snow conditions with good visibility, final clearing and clean-up
- *Ideal application: large parking lots, widening roadways*

OPERATING YOUR SNOW BLADE

To pin wings in position for the straight blade option:

1. Fully angle the blade to one side. Lower the blade and turn the vehicle ignition OFF.
2. Standing behind the blade, install a 3/4" x 9" clevis pin down through the holes in the back of the blade assembly, as shown.

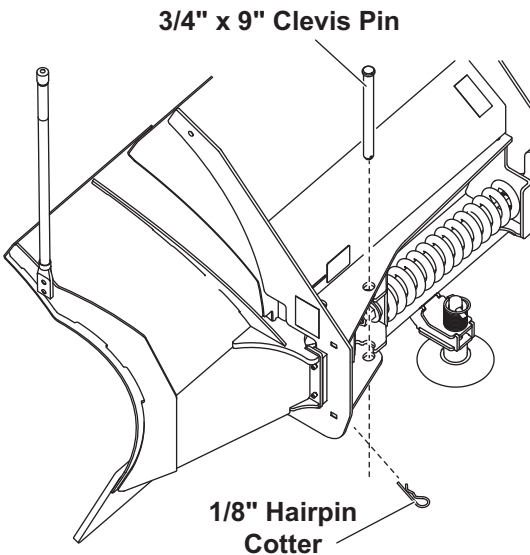

3. Secure the pin with a 1/8" hairpin cotter.
4. Repeat Steps 1 through 3 on the opposite side.
5. To remove the clevis pins, reverse the above procedure.

DISC SHOE ADJUSTMENT

⚠ WARNING

Blade can drop unexpectedly. Place blade on stand assembly. Failure to do so could result in serious personal injury.

Recommended Shoe Adjustments

For gravel surfaces: The bottom surface of the shoe should be 1/4" to 1/2" below the cutting edge.

For hard surfaces (concrete or asphalt): Bottom surface of shoe should be even with the cutting edge.

1. Raise the blade one foot off the road surface. From in front of the blade, place stand assembly under the cutting edge.
2. Lower the blade onto stand assembly.
3. Remove the linchpin and slide the disc shoe down and out of the shoe holder.
4. Remove one or more washers from the shoe stem, and reinstall the shoe into the shoe holder. Place the removed washers onto the shoe stem above the shoe holder.

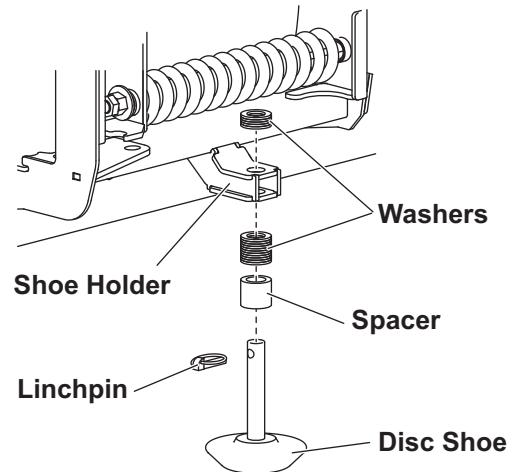

5. Reinstall the linchpin.
6. Raise the blade slightly. Remove the stand assembly.
7. Stand 8 feet clear of the blade when checking the height adjustment of cutting edge to road surface.

OPERATING YOUR SNOW BLADE

TRANSPORTING snow blade

⚠ WARNING

Position the blade so it does not block the vehicle headlamp beam.

Do not change blade position while traveling. You could suddenly lower blade accidentally.

⚠ CAUTION

Transport speed should not exceed vehicle manufacturer's recommendations. Further reduce speed under adverse travel conditions.

These instructions are for driving short distances to and from plowing jobs. For long trips, remove the snow blade from the vehicle, following recommended mechanical lifting cautions and procedures.

1. Completely raise the blade.
2. Adjust the blade height for maximum vehicle headlamp illumination.
3. Adjust the blade to the straight position.

DRIVING AND PLOWING ON SNOW AND ICE

⚠ WARNING

Drinking then driving or plowing is very dangerous. Your reflexes, perceptions, attentiveness, and judgment can be affected by even a small amount of alcohol. You can have a serious or even fatal collision if you drive after drinking. Please do not drink and then drive or plow.

Refer to vehicle owner's manual instructions for driving in snow and ice conditions. Remember, when you drive on snow or ice, your wheels will not get good traction. You cannot accelerate as quickly, turning is more difficult, and you will need longer braking distance.

Wet and hard-packed snow or ice offers the worst traction. It is very easy to lose control. You will have difficulty accelerating. If you do get moving, you may have poor steering and difficult braking, which can cause you to slide out of control.

Here are some tips for driving in these conditions:

- Drive defensively.
- Do not drink, then drive or plow snow.
- Plow or drive only when you have good visibility for operating a vehicle.
- If you cannot see well due to snow or icy conditions, you will need to slow down and keep more space between you and other vehicles.
- Slow down, especially on higher-speed roads. Your headlamps can light up only so much road ahead.
- If you are tired, pull off in a safe place and rest.
- Keep your windshield and all glass on your vehicle clean to see around you.
- Dress properly for the weather. Wear layers of clothing; as you get warm, you can take off layers.

OPERATING YOUR SNOW BLADE

PLOWING SNOW

⚠ CAUTION

Wear a seat belt when plowing snow. Hidden obstructions could cause the vehicle to stop suddenly, resulting in personal injury.

⚠ CAUTION

Flag any obstructions that are hard to locate under snow to prevent damage to product or property.

⚠ CAUTION

Never stack snow with the blade angled. This could damage the snow blade.

⚠ CAUTION

Plowing speed should not exceed 10 mph (16 km/h).

NOTE: Only the driver should be in the vehicle cab when the snow blade is attached.

General Instructions

1. Before plowing, make sure that you know of any obstructions hidden beneath the snow, such as bumper stops in parking lots, curbs, sidewalk edges, shrubs, fences, or pipes sticking up from the ground. If unfamiliar with the area to be plowed, have someone familiar with the area point out obstacles.
2. If possible and you have good visibility, plow during the storm rather than letting snow accumulate.
3. Do not exceed 10 mph (16 km/h) when plowing snow.

Hard-Packed Snow

1. Raise the disc shoes so that the cutting edge comes into direct contact with the pavement.
2. Use the lowest gear to place maximum power behind the cutting edge.
3. An angled blade is more effective for removing hard-packed snow.

Deep Snow

1. For straight blades, shear off top layers by plowing with the blade raised 3 to 4 inches for the initial pass.
2. Bite into the edges using only partial blade width until the job is cut down to size for full-blade plowing.

Rule of thumb:

- 6" of snow — plow with entire blade width;
- 9" of snow — plow with 3/4 blade width;
- 12" of snow — plow with 1/2 of the blade.

Experience and "feel" are the best guides.

3. When plowing deep snow, be sure to keep the vehicle moving.
4. For increased traction, use tire chains where legal.

OPERATING YOUR SNOW BLADE

Clearing Driveways

1. Head into the driveway with the blade angled and plow the snow away from any buildings. Widen driveway by rolling snow away from any buildings.
2. If a building is at the end of the driveway, plow to within a vehicle length of the building. Push as much snow as possible off the driveway.
3. With a raised blade, drive through remaining snow to building. Drop blade and "back drag" snow away from the building at least one vehicle length. Repeat if necessary.
4. Back vehicle to the building and plow forward, removing the remaining snow from the driveway. Check municipal ordinances for proper disposal of snow.

Clearing Parking Lots

1. Clear areas in front of buildings first. With blade raised, drive up to the building. Drop blade and "back drag" the snow away from building. When snow is clear of the buildings, turn the vehicle around and push snow away from the buildings toward outer edges of lot.
2. Plow a single path down the center in the lengthwise direction.
3. With the blade in the angle position, plow successive strips lengthwise until the area is cleared and snow is "stacked" around the outer edges.
4. If snow is too deep to clear in above manner, clear main traffic lanes as much as possible. Check municipal ordinances for proper disposal of snow.

PARKING WITH BLADE ATTACHED

WARNING

Lower the blade when the vehicle is parked. Keep 8 feet clear of the blade when it is being raised, lowered or angled. Temperature changes could change hydraulic pressure, causing the blade to drop unexpectedly or damaging hydraulic components. Failure to do this could result in serious personal injury.

Whenever you park your vehicle, completely lower the blade to the ground.

TOWING A DISABLED OR STUCK VEHICLE

Do not use any snow blade components as an attaching point when retrieving, towing, or winching a disabled or stuck vehicle.

MAINTENANCE

PRESEASON CHECK

WARNING

Lower the blade when the vehicle is parked. Keep 8 feet clear of the blade when it is being raised, lowered or angled. Temperature changes could change hydraulic pressure, causing the blade to drop unexpectedly or damaging hydraulic components. Failure to do this could result in serious personal injury.

Before the snow season, check your equipment to make sure that it is in working condition. Here are some tips for getting your equipment ready:

- Replace worn or damaged parts.
- Check all mounting points and tighten fasteners, on both snow blade and vehicle. Verify that all cotter pins are in place.
- Repaint blade assembly and attachments, as necessary, to protect the metal.
- Install auxiliary and flashing lights for compliance and visibility in accordance with local regulations.
- Check vehicle headlamps, auxiliary lights, heater, and windshield wipers for proper operation.
- Inspect and test your battery. Recharge or replace as necessary.
- Ballast may be necessary, or beneficial, on some vehicles to provide maximum traction, braking, and handling.
- Any ballast material (such as sand and blocks) must be solidly secured to the vehicle, preventing it from moving under harsh plowing conditions.

POSTSEASON MAINTENANCE

NOTE: Coat all electrical connections with dielectric grease.

- Clean and paint blade and components as needed.
- Apply general purpose petroleum grease to exposed chrome surfaces of the rams to prevent rust.
- Lubricate all pivot points with general purpose petroleum grease.

MAINTENANCE

MAINTENANCE AND ADJUSTMENT

⚠ WARNING

Lower the blade when the vehicle is parked. Keep 8 feet clear of the blade when it is being raised, lowered, or angled. Temperature changes could change hydraulic pressure, causing the blade to drop unexpectedly or damaging hydraulic components. Failure to do this could result in serious personal injury.

Your snow blade is designed for rugged, dependable service. However, like the vehicle on which it is mounted, it needs regular care and maintenance.

Check the following before and frequently during the plowing season:

1. Make sure that all fasteners, mounting bolts, and hydraulic connections are tight. Pay particular attention to the 1" pivot bolt.

NOTE: Pay particular attention to the 1" pivot bolts connecting the A-frame to the universal plate. These bolts should remain slightly loose to allow for oscillation.

2. Check all plugs and seals for hydraulic fluid leaks. Repair as necessary.

⚠ CAUTION

Overtightening springs will not increase blade trip force and can damage the springs.

3. **Trip Spring Adjustment:** To adjust trip spring tension, adjust the eyebolts located at the top of the blade. Tighten the adjusting nut until the coils begin to separate. When tension is properly adjusted, a sheet of paper should pass between the second and third coils. When the proper tension is reached, tighten locknut.
4. **Blade Finish:** If the powder-coated finish is nicked or scratched, repair the surface, and paint with an approved enamel paint.

3. MAINTENANCE

3.1 HYDRAULIC HOSE AND FITTING REPLACEMENT

⚠ WARNING

Lower the blade when the vehicle is parked. Keep 8 feet clear of the blade when it is being raised, lowered or angled. Temperature changes could change hydraulic pressure, causing the blade to drop unexpectedly or damaging hydraulic components. Failure to do this could result in serious personal injury.

DO NOT use thread sealant/tape on hoses or fittings. This could damage product. Follow recommended replacement procedures for fittings and hoses.

1. Lower the snow blade completely.
2. Carefully note hose routing for proper reassembly.
3. Loosen hoses or fittings slowly to relieve any residual pressure.
4. To remove a hose, loosen and unscrew the hose flare nut from the fitting.
5. To remove a fitting, loosen the jam nut and unscrew the fitting from the port.

3.2 Installing Hydraulic Fittings and Hoses

NOTE: Overtightening JIC hose fitting ends will result in a fractured fitting.

DO NOT use any type of sealant or tape on the fittings or hoses. This could damage product. Always use two wrenches to ensure proper tightening of fittings and hoses.

Use the following procedure to install SAE O-ring fittings in valve block and rams:

1. Turn jam nut on fitting as far back as possible.
2. Lubricate O-ring with clean hydraulic fluid.
3. Screw fitting into port by hand until the washer contacts the port face and shoulder of the jam nut threads.
4. Unscrew fitting to proper position, no more than one full turn.
5. Using two wrenches, hold fitting body in position and tighten jam nut until the washer again contacts port face, then tighten an additional 1/8 to 1/4 turn to lock fitting in place. Final torque on the jam nut should be approximately 20 ft-lb.

Use the following procedure to install hydraulic hoses:

1. Screw flare nut onto fitting flare and hand tighten.
2. Align hose so there are no twists or sharp bends and so it will not be pinched or pulled by moving parts.
3. Using two wrenches, hold the hose in position and tighten flare nut 1/8 to 1/4 turn beyond hand tight. Final torque on the flare nut should be approximately 20 ft-lb.

Once all parts are installed, top off the hydraulic fluid level as recommended by the skid steer manufacturer.

3. MAINTENANCE

3.3 VEHICLE

The snow blade operating vehicle shall be maintained according to manufacturer's recommendations. Tire pressure shall be maintained according to manufacturer's recommendation.

3.4 RECYCLE

When your snow blade has performed its useful life, the majority of its components can be recycled as steel or aluminum. Hydraulic fluid shall be disposed according to local regulations. Balance of parts made of plastic shall be disposed of in a customary manner.

3.5 BLADE FINISH

If the powder-coated finish is nicked or scratched, repair the blade surface with paint. Clean and repaint parts as necessary.

3.6 EMERGENCY TOOLS

We suggest that you keep the following items in your vehicle for emergency use:

- 10" adjustable wrench
- Pliers (locking, adjustable, etc.)
- Medium screwdriver
- 11/16" open-end wrench
- 3/4" open-end wrench
- Miscellaneous fasteners

3.7 TROUBLESHOOTING

If you have followed all the guidelines listed in the Maintenance section of this manual and cannot resolve issues with the operation of your snow blade, contact one of our authorized outlets for repair information.

TECHNICAL SPECIFICATIONS

PART	SPECIFICATION	AUTO WING BLADE
Moldboard	Length	102" (8' & 6")
	Thickness	12 ga
	Height	29 1/2"
	Reinforcement	4 Ribs at 1/4"
	Cutting Edge (1080)	1/2" x 6"
	Finish	Poweder Coat Black
	Trip Mechanism	(4) 3/8" Hooked Extension Springs
A-Frame	Material	Square Tube
	Finish	Powder Coat Black
Manifold	Construction	Anodized Aluminum
	Valves	Hydraulic Cartridge
Cylinders	Angle Cylinders	2
	Stroke	12"
	Rod Diameter	1-1/2"
Snow Blade	Weight	918 lb
	Adjustable Plow Shoes	(2) Heavy Duty Cast Steel

SKID STEER – AUTO WING BLADE

Blade Components

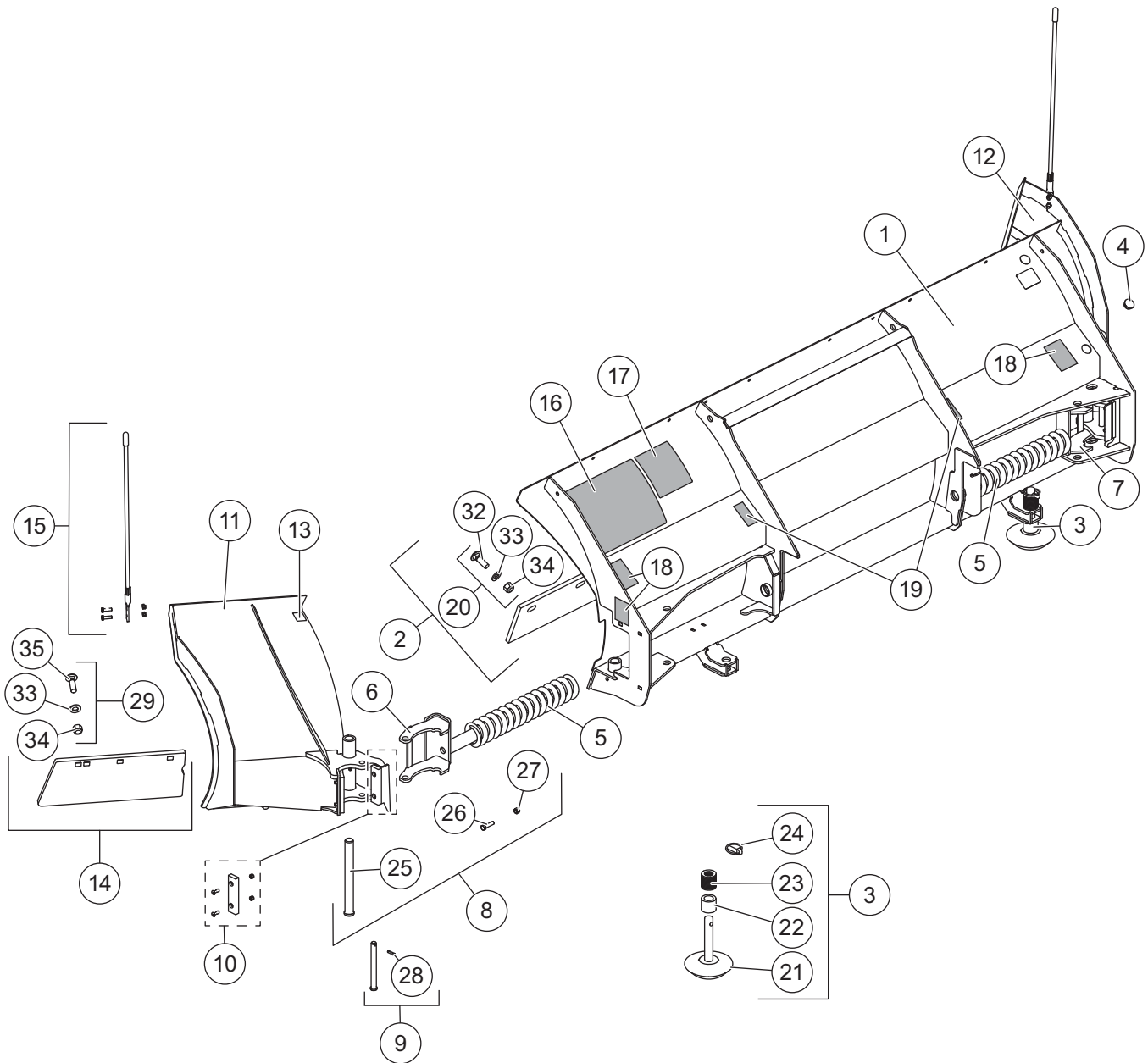

SKID STEER – AUTO WING BLADE

ITEM	PART NUMBER	DESCRIPTION	QTY
1	220800	Main Frame Weldment	1
2	220885	Replacement Cutting Edge Kit for Main Frame (Includes Hardware)	1
3	220816	Skid Shoe Kit (Includes Spacers & Pin)	2
4	220801	Finishing Plug 1.00"	2
5	220802	Compression Spring	2
6	220803	Spring Guide - Left	1
7	220804	Spring Guide - Right	1
8	220820	Side Wing Pivot Pin Kit (Includes Hardware)	2
9	220805	Spring Guide Pin (Includes Roll Pin Retainer)	2
10	220806	Side Wing Bumper Kit (Includes Hardware)	4
11	220807	Side Wing - Left	1
12	220808	Side Wing - Right	1
13	220809	Side Wing Wear Strip - Top	2
14	220886	Side Wing Cutting Edge Kit w/Hardware (Fits Left & Right)	1
15	220810	Poly Side Guide 24" (Set of 2 Includes Hardware)	1
16	220811	Decal - Attach/Detach, Skid Steer	1
17	220812	Decal - Warning/Caution, Snow Blade	1
18	220813	Decal - Warning/Multiple Pinch Points	4
19	220814	Decal - Warning, Crush Hazard	2
20	-	Main Frame Cutting Edge	1
21	220815	Hardware Kit for Main Cutting Edge	1
22	220816-1	Skid Shoe Weldment Only	1
23	220817	Skid Shoe Spacer 1-1/8 ID 1-5/8 OD X 1-1/2	2
24	220818	Skid Shoe Flat Washer	34
25	220819	Skid Shoe Linchpin 7/16 X 1-3/4	2
26	220820-1	Side Wing Pivot Pin 1 X 10-1/4	1
27	299428	Side Wing Pivot Pin Retaining Bolt 3/8-16 X 1-1/2 Carriage Bolt G5	2
28	299625	Side Wing Pivot Pin Locknut 3/8-16 GB	2
29	220823	Spring Guide Pin Kit: 1/4 X 1 Coiled Spring Pin	1
30	-	Side Wing Cutting Edge	2
31	220824	Side Wing Cutting Edge Hardware Kit (6 Bolts, Washers & Nuts)	1
32	299452	Cutting Edge Bolt for Main Frame 5/8-11 X 2-1/2 Carriage Bolt G5	8
33	299844	Cutting Edge Hardened Flat Washer 5/8"	8
34	299627	Cutting Edge Locknut 5/8-11" GB	8
35	220827	Cutting Edge Bolt for Side Wing 5/8-11 X 2-1/2 Carriage Bolt G5	6

SKID STEER – AUTO WING BLADE

Blade Components

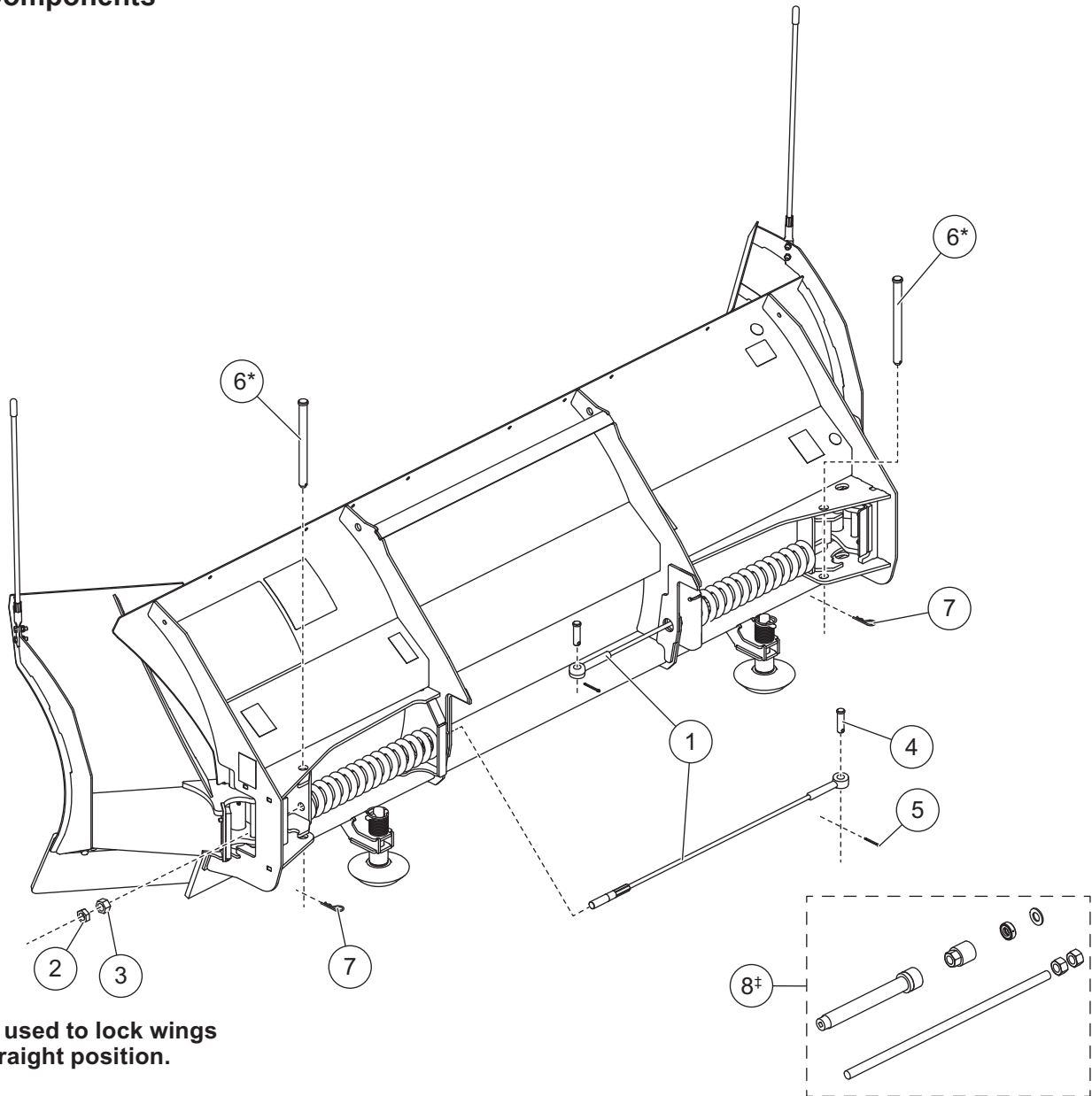

* Pins used to lock wings in straight position.

ITEM	PART NUMBER	DESCRIPTION	QTY
1	220828	Cable Assembly w/Hardware (includes item 2-5)	2
2	220829	Cable Jam Nut Only 3/4-10	2
3	220830	Cable Nut Only 3/4-10	2
4	220831	Cable Eyelet Pin 0.625 x 2.33	2
5	220832	Cable Eyelet Pin Retainer 1/4 x 1-1/2	2
6	220833	Side Wing straight Lockout Pin 3/4 x 9	6
7	220834	Side Wing Straight Lockout Pin Hairpin Retainer 1/8	2
8	220835	Side Wing Service Tool (Required for Removing Springs)	-

SKID STEER – AUTO WING BLADE

Quadrant Components

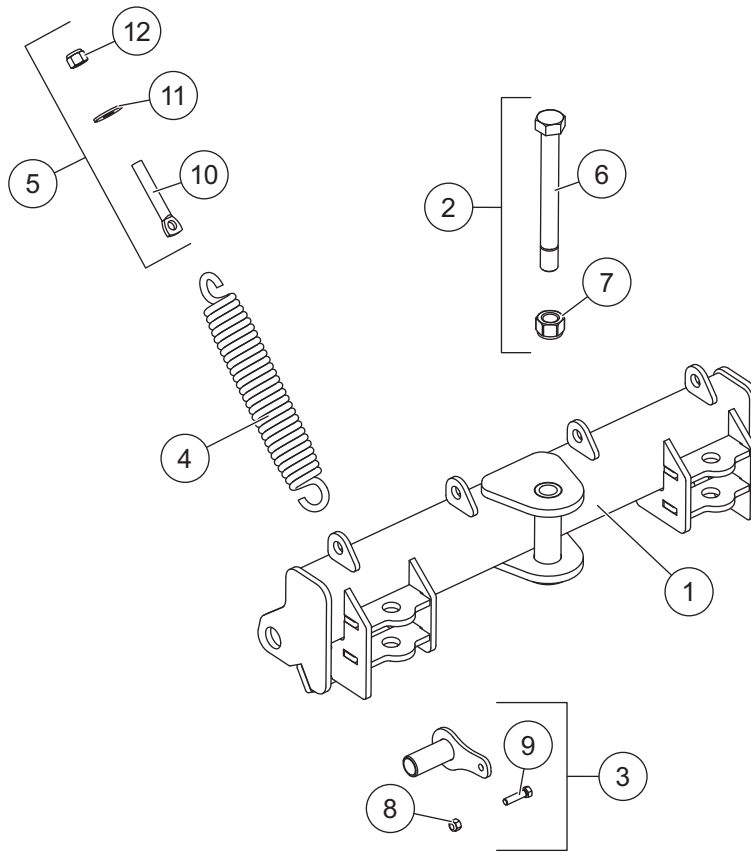

ITEM	PART NUMBER	DESCRIPTION	QTY
1	220836	Quadrant Main Weldment	1
2	220837	Trip Pivot Pin (Includes Hardware)	2
3	220838	Trip Spring	4
4	220839	Main Angle Pivot Bolt 1-8 x 9 G5 Special	1
5	220840	Main Angle Pivot Locknut 1-8 GB	1
6	220841	Trip Pivot Pin Retaining Locknut 3/8-16 x 1-1/2 G5	2
7	220842	Trip Pivot Pin Retaining Bolt 3/8-16 x 1-1/2 G5	2
8	220843	Trip Spring Eyebolt Only 5/8-11 x 4 G2	4
9	220844	Trip Spring Eyebolt Hardened Flat Washer 5/8	4
10	220845	Trip Spring Eyebolt Locknut 5/8-11 GB	4

SKID STEER – A-FRAME COMPONENTS

A-Frame Components

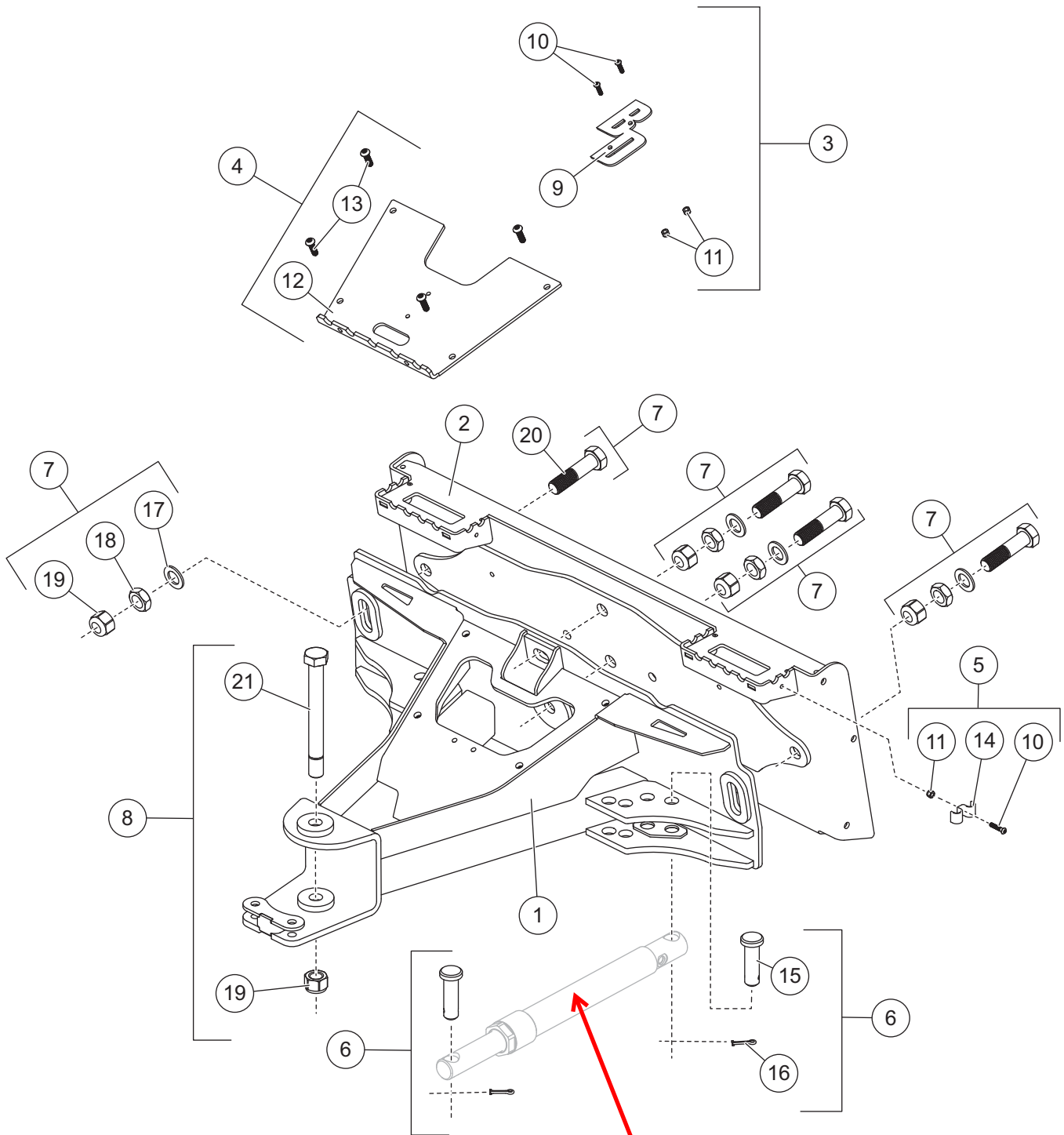

Cylinder 220862 1.5" x 12"

SKID STEER – A-FRAME COMPONENTS

ITEM	PART NUMBER	DESCRIPTION	QTY
1	220836	A-Frame Weldment	1
2	220847	Universald Skid Steer Mount to Fit A-Frame	1
3	220854	Hose Clamp Kit (Includes Hardware)	1
4	220855	Cylinder Retaining Pin Kit (4 Pins & Cotter Pins)	4
5	220860	Mounting Plate Hardware Kit (Includes 4 Bolts, Washers, Jam Nuts & Locknuts)	4
-	220848	Decal - Information, Hydraulic Guide, Skid Steer	1
6	220849	Blue Diamond Logo Plate	1
7	220850	Logo Plate Bolt 1/4-20 x 1	2
8	220851	Logo Plate Locknut 1/4-20	1
9	220852	Step Weldment	1
10	220853	Step Weldment Bolt 3/8-16 x 1-1/4	4
11	-	Double Hose Retaining Bracket	1
12	-	Cylinder Pin	1
13	-	Cylinder Pin Retainer	1
14	220857	Flat Washer 1" Special	1
15	220858	Jam Nut 1-8 G5	1
16	220859	Locknut 1-8 G5	1
17	220870	Bolt 1-8 x 4-1.4	1
18	220861	Angle Pivot Bolt 1-8 x 9 G5 Special	1

For hydraulic relief manifold and fittings, see Hydraulic Components page.

SKID STEER – ANGLE RAMS

Angle Ram Components

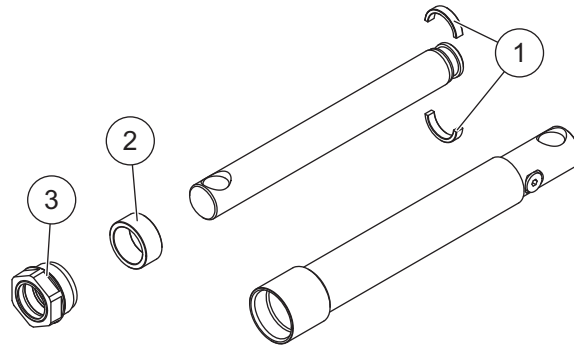

ITEM	PART NUMBER	DESCRIPTION	QTY
1	220863	Cylinder Bearing Seal Kit	1
2	220864	Cylinder Spacer	1
3	220865	Cylinder Gland Nut	1

Cylinder 220862 1.5" x 12"

SKID STEER – HYDRAULIC COMPONENTS

Hydraulic Components

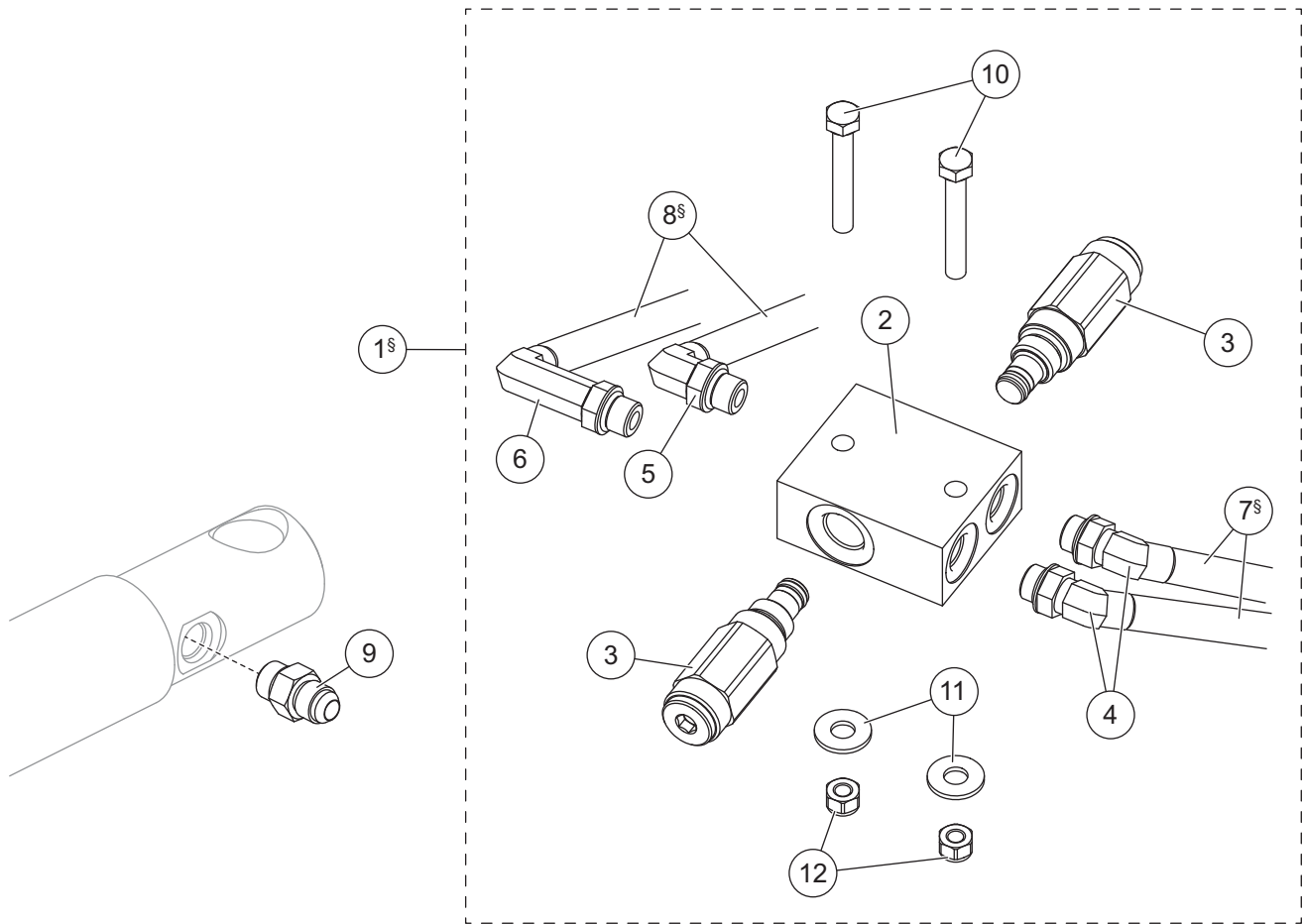

ITEM	PART NUMBER	DESCRIPTION	QTY
1	220866	Complete Relief Manifold w/Valves, Fittings & Hardware (Hoses NOT Included)	1
2	220867	Relief Manifold Only	1
3	220868	Relief Valve, 3300 psi	2
4	220869	45° Elbow 6 M JIC/-6M ORB	2
5	295030-M06ORB-M06JIC	90° Elbow 6 M JIC/-6 M ORB	1
6	220871	90° Elbow, Extra Long 6M JIC/-6 M ORB	1
7	220872	Hose, 3/8 x 84 W/F JIC Ends	2
8	220873	Hose, 3/8 x 42 W/F JIC Ends	2
9	220876	Connector, Short -6M JIC/-6 M ORB	2
10	220877	Bolt 5/16-18 x 2-1/4 G5	2
11	299720	Flat Washer 5/16	2
12	299620	Locknut 5/16-18 GB	2

§ Hoses not included in item 1.



MANUFACTURER'S LIMITED WARRANTY

BLUE DIAMOND ATTACHMENTS, a manufacturer of quality attachments, warrants new BLUE DIAMOND ATTACHMENTS products and/or attachments at the time of delivery to the original purchaser, to be free from defects in material and workmanship when properly set up and operated in accordance with the recommendations set forth by BLUE DIAMOND ATTACHMENTS, LLC.

BLUE DIAMOND ATTACHMENTS liability for any defect with respect to accepted goods shall be limited to repairing the goods at a BLUE DIAMOND ATTACHMENTS designated location or at an authorized dealer location, or replacing them, as BLUE DIAMOND ATTACHMENTS shall elect. The above shall be in accordance with BLUE DIAMOND ATTACHMENTS warranty adjustment policies. BLUE DIAMOND ATTACHMENTS obligation shall terminate twelve (12) months for the Snow Blade Auto Wing after the delivery of the goods to original purchaser.

This warranty shall not apply to any machine or attachment which shall have been repaired or altered outside the BLUE DIAMOND ATTACHMENTS factory or authorized BLUE DIAMOND ATTACHMENTS dealership or in any way so as in BLUE DIAMOND ATTACHMENTS judgment, to affect its stability or reliability, nor which has been subject to misuse, negligence or accident beyond the Company recommended machine rated capacity.

WARRANTY CLAIM

To submit a warranty claim, a return authorization from BLUE DIAMOND ATTACHMENTS must be obtained. The failed part may then be returned. Tampering with the failed part may void the warranty. This warranty does not include freight or delivery charges incurred when returning machinery for servicing. Dealer mileage, service calls, and pickup/delivery charges are the customers' responsibility.

EXCLUSIONS OF WARRANTY

Except as otherwise expressly stated herein, BLUE DIAMOND ATTACHMENTS makes no representation or warranty of any kind, expressed or implied, AND MAKES NO WARRANTY OF MERCHANTABILITY IN RESPECT TO ITS MACHINERY AND/OR ATTACHMENTS ARE FIT FOR ANY PARTICULAR PURPOSE. BLUE DIAMOND ATTACHMENTS shall not be liable for incidental or consequential damages for any breach or warranty, including but not limited to inconvenience, rental of replacement equipment, loss of profits or other commercial loss. Upon purchase, the buyer assumes all liability for all personal injury and property resulting from the handling, possession, or use of the goods by the buyer.

No agent, employee, or representative of BLUE DIAMOND ATTACHMENTS has any authority to bind BLUE DIAMOND ATTACHMENTS to any affirmation, representation, or warranty concerning its machinery and/or attachments except as specifically set forth herein.

This warranty policy supersedes any previous documents.

NOTE: Blue Diamond Attachments is a trademark of BLUE DIAMOND ATTACHMENTS, LLC.



QUALITY | DEPENDABILITY | INTEGRITY

Blue Diamond® Attachments
4512 Anderson Road, Knoxville, TN 37918
888-376-7027