

Extreme Duty Series 2 Augers

Operation and Maintenance Manual



888-376-7027 | BlueDiamondAttachments.com

Register your
WARRANTY
within 30 days
of purchase



Introduction: Owner Information

Thank you for your decision to purchase a Blue Diamond® Extreme Duty Series 2 Auger. To ensure maximum performance of your equipment, it is mandatory that you thoroughly study the Operator's Manual and follow the recommendations. Proper operation and maintenance are essential to maximize equipment life and prevent personal injury.

Operate and maintain this equipment in a safe manner and in accordance with all applicable local, state, and federal codes, regulations and /or laws. Follow all on-product labeling and instructions.

Make sure that all personnel have read this Operator's Manual and thoroughly understand safe and correct operating, installation and maintenance procedures.

Blue Diamond® is continually working to improve its products. Blue Diamond® reserves the right to make any improvements or changes as deemed practical and possible without incurring any responsibility or obligation to make any changes or additions to equipment sold previously.

Although great care has been taken to ensure the accuracy of this publication, Blue Diamond® makes no warranty or guarantee of any kind, written or expressed, implied or otherwise with regard to the information contained within this manual. Blue Diamond® assumes no responsibility for any errors that may appear in this manual and shall not be liable under any circumstances for incidental, consequential or punitive damages in connection with, or arising from the use of this manual.

Keep this manual available for frequent reference. All new operators or owners must review the manual before using the equipment and annually thereafter. Contact your Blue Diamond® Attachments Dealer for assistance, information, or additional copies of the manual. Contact www.bluediamondattachments.com or call 888-376-7027 for a complete list of dealers in your area.

Serial Number Location:

Please record attachment information in the space provided for future reference.



Model Number: _____

Serial Number: _____

Dealer Name: _____

Dealer Number: _____

Date of Purchase: _____

The serial number plate is located on the side of the drive as shown above.

Always use your serial number when requesting information or when ordering parts.

NOTE: The directions left, right, front, and rear, as mentioned throughout this manual, are as viewed from the operator's position.

Table of Contents

| | |
|--|----|
| Introduction: Owner Information | 2 |
| 1. Introduction..... | 4 |
| 1.1 Attachment Identification | 4 |
| 1.2 About this Attachment | 5 |
| 1.3 Attachment Model Numbers | 5 |
| 2. Safety | 6 |
| 2.1 General Safety Information | 6 |
| 2.2 Operators | 7 |
| 2.3 Safety Guidelines | 8 |
| 3. Operation | 11 |
| 3.1 Pre-Operation Inspection | 11 |
| 3.2 Setup Procedure | 11 |
| 3.3 Entering and Exiting the Host Machine | 12 |
| 3.4 Attachment Installation with Skid Steer | 13 |
| 3.5 Attachment Installation with Excavator | 14 |
| 3.6 Installing Bits & Extensions to the Auger Drive | 16 |
| 3.7 Cold Weather Startup Information | 16 |
| 3.8 Operating the Attachment | 17 |
| 3.9 Skid Steer Operating Positions | 18 |
| 3.10 Excavator Operating Positions | 19 |
| 4. Maintenance | 20 |
| 4.1 Service Schedule | 20 |
| 4.2 Gear Oil Change Schedule | 21 |
| 4.3 How to Check the Gearbox Oil Level | 22 |
| 4.4 How to Drain Gearbox Oil | 22 |
| 4.5 How to Change or Refill the Gearbox Oil | 22 |
| 4.6 How to Replace Teeth on Auger Bits | 23 |
| 4.7 Maintaining Auger Bits | 25 |
| 4.8 Troubleshooting | 26 |
| 5. Parts..... | 27 |
| 5.1 Main Components – EX1 | 27 |
| 5.2 Main Components – EX2, EX3, & EX4 | 28 |
| 5.3 Main Components – EX4HF | 29 |
| 5.4 Safety Decals | 30 |
| 6. Specifications | 31 |
| 6.1 Attachment Specifications | 31 |
| 6.2 Torque Specifications | 32 |
| Warranty | 33 |

1. Introduction

1.1 Attachment Identification

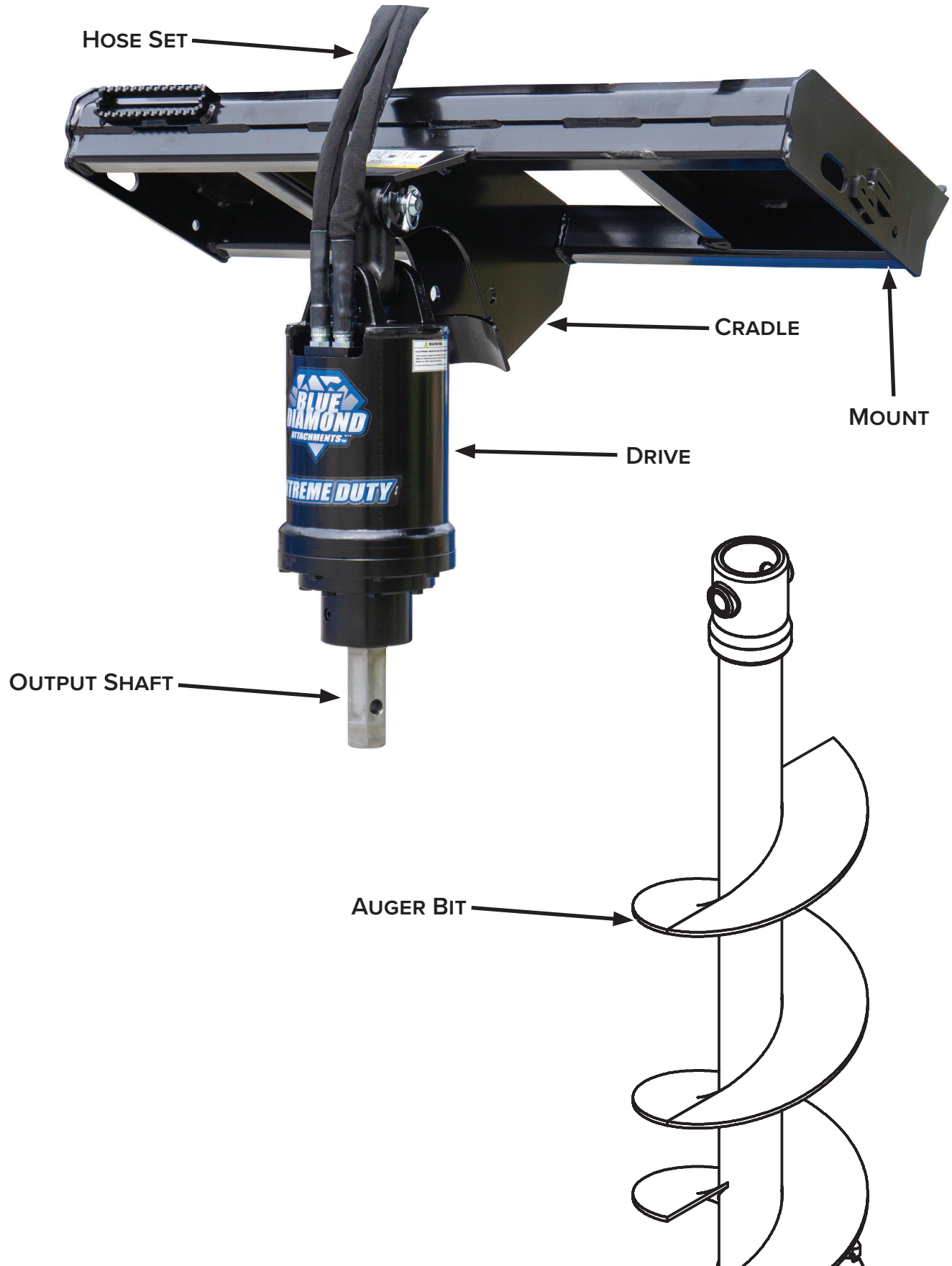

1. Introduction

1.2 About this Attachment

The Blue Diamond® Extreme Duty Series 2 Auger offers the ultimate in performance, quality, and cost-effectiveness for digging post holes and drilling soil with tractors, mini skid steers, skid steers, and excavators. Designed with high-grade materials and innovation, this attachment allows the gearbox to go down the hole, maximizing drilling depth while eliminating downtime.

1.3 Attachment Model Numbers

| MODEL NUMBER | DESCRIPTION | RECOMMENDED FLOW |
|--------------|-------------|------------------|
| 105705* | EX1 | 6 – 16 GPM |
| 105708* | EX2 | 10 – 26 GPM |
| 105712* | EX3 | 10 – 30 GPM |
| 105715* | EX4 | 10 – 30 GPM |
| 105720* | EX4HF | 10 – 36 GPM |
| 105725* | EX5HF | 10 – 36 GPM |
| 105728* | EX6HF | 12 – 36 GPM |
| 105730* | EX7HF | 14 – 36 GPM |
| 105840** | EX9HF | 18 – 48 GPM |
| —** | EX12HF | 22 – 48 GPM |
| 105852** | EX13HF | 26 – 54 GPM |
| 105854** | EX16HF | 26 – 54 GPM |
| 105856** | EX20HF | 26 – 60 GPM |
| 105858** | EX25HF | 26 – 60 GPM |
| 105860** | EX30HF | 26 – 60 GPM |

*The model numbers are for the auger drive only, the mount is not included. Mini skid steer, skid steer, and excavator mounts are available, depending on the model.

**Available for excavators only. Mount must be specified.

2. Safety

2.1 General Safety Information



This **SAFETY ALERT SYMBOL** identifies important safety messages on the equipment and in the owner's manual. When you see this symbol, be alert to the possibility of personal injury and carefully read the message that follows.



The signal word **IMPORTANT** identifies procedures which must be followed to avoid damage to the machine.



The signal word **DANGER** on the machine and in the manuals indicates a hazardous situation which, if not avoided, will result in death or serious injury.



The signal word **WARNING** on the machine and in the manuals indicates a potentially hazardous situation which, if not avoided, could result in death or serious injury.



The signal word **CAUTION** on the machine and in the manuals indicates a potentially hazardous situation which, if not avoided, may result in minor or moderate injury. It may also be used to alert against unsafe practices.

NOTE: Notes are used to indicate important information. This information may be repeated in other areas of the manual.

Operating Safety

- Read and follow instructions in this manual and the machine's Operator's Manual before operating.
- The manual must always remain with the machine. In case of loss or damage, request a new copy from your dealer or from Blue Diamond®.
- Strictly follow all rules prescribed by the safety pictograms/decals applied to the machine. Ensure that all safety pictograms/decals are legible. If pictograms/decals are worn, they must be replaced with new ones obtained from Blue Diamond® and placed in the position indicated by this manual.
- Before using the machine, make sure that all safety devices are installed and in good working condition. In case of damaged or missing shields, replace them immediately.
- It is absolutely forbidden to remove or alter safety devices and/or safety precautions
- Pay maximum attention to avoid any accidental contact with rotating parts of the machine.
- If the use of the machine is required at night or in conditions of reduced visibility, use the lighting system of the host machine and an auxiliary lighting system if required.
- Exposure to respirable crystalline silica dust along with other hazardous dusts may cause serious or fatal respiratory disease. It is recommended to use dust suppression, dust collection, and if necessary, personal protective equipment (PPE) during the operation of any attachment that may cause high levels of dust.
- Remove paint before welding or heating. Hazardous fumes/dust can be generated when paint is heated by welding, soldering or using a torch. Do all work outside or in a well ventilated area and dispose of paint and solvent properly. When sanding or grinding paint, avoid breathing the dust. Wear an approved respirator. If you use solvent or pain stripper, remove the stripper with soap and water before welding. Remove solvent or paint stripper containers and other flammable material from the area.

2. Safety



2.2 Operators

Qualified Operators

The operator is a person suited to the work and who is physically and psychologically able to withstand the demands connected with operating the equipment for its intended use. The operator must not allow anyone to approach the machine while it is working and must not allow external personnel to operate the machine or attachment.

The operator is to follow the given instructions in this manual and the machine operator's manual in order to obtain maximum performance, minimal fuel consumption, and maximum safety for himself and for others.

The operator is responsible for scrupulously observing all the instructions given in this manual.

 **DANGER** 

AVOID SERIOUS INJURY OR DEATH

Operators must receive instructions before operating the machine. Untrained operators can cause serious injury or death.

For an operator to be qualified, he or she must not use drugs or alcoholic drinks which impair alertness or coordination while working. An operator who is taking prescription drugs must get medical advice to determine if he or she can safely operate a machine and the equipment.

For an operator to be qualified, he or she must have read and understood the instructions of this manual, he or she must make adequate preparation for the proper use of the machine, and he or she must hold a driving license.

In case of doubt regarding the use of the machine and/or the interpretation of this manual, the operator must contact either their dealer or Blue Diamond®.

Operator Training

- Check the rules and regulations at your location. The rules may include an employer's work safety requirements. Regulations may apply to local driving requirements or use of a Slow Moving Vehicle (SMV) emblem. Regulations may identify a hazard such as a utility line.
- The new operator must start in an area without bystanders and use all the controls until he or she can operate the machine safely under all conditions of the work area.

Operator Safety

- Before starting, and during operation of the attachment, make sure there are no people or animals in the operation area; the machine can project material from the back with risks of serious injury or death.
- During operation, adjustment, maintenance, repairing, or transportation of the machine, the operator must always use appropriate Personal Protective Equipment (PPE) including but not limited to safety glasses, working gloves, dust mask, safety helmet, and hearing protection.
- Do not operate the attachment or machine while wearing loose fitting clothing that can be entangled or caught in parts of the machine.
- Do not operate the implement when tired, not in good condition, or under the influence of alcohol or drugs.

2. Safety

2.3 Safety Guidelines

Operating Safety

- Read and follow instructions in this manual and the machine's Operator's Manual before operating.
- Under no circumstances should young children be allowed to work with this equipment.
- This equipment is dangerous to persons unfamiliar with its operation.
- Check for overhead and / or underground lines before operating equipment.
- In addition to the design and configuration of equipment, hazard control and accident prevention are dependent upon the awareness, concern, prudence, and proper training of personnel involved in the operation, transport, maintenance, and storage of equipment.
- Check that the attachment is securely fastened to the machine.
- Make sure all the machine controls are in the NEUTRAL before starting the machine.
- Operate the equipment only from the operator's position.
- Operate the equipment according to the Operator's Manual.
- When learning to operate the equipment, do it at a slow rate in an area clear of bystanders.
- Do not permit personnel to be in the work area when operating the equipment.
- All bystanders should be kept at a minimum of 20 feet (6 m) away from the working area of the drive.
- The equipment must be used ONLY on approved machines.
- Do not modify the equipment in any way. Unauthorized modification may impair the function and / or safety and could affect the life of the equipment. Any modification not authorized by Blue Diamond® will result in the warranty being voided.
- Do not make any adjustments or repairs on the equipment while the machine is running.
- Keep shields and guards in place. Replace if damaged.
- DO NOT operate equipment in poor visibility conditions such as fog, darkness, or any conditions that limit clear visibility less than 300 feet (100 m) in front of and to the sides of the equipment.
- Do not allow anyone to climb or ride on a drill mast, planetary drive, auger bits, or auger extensions at any time, including while stationary, in operation, or being moved / rotated.
- When conditions make it necessary to slow ground speed, shift to a lower gear rather than reducing engine speed. The engine will maintain rated speed and keep cutter running at optimum cutting speed.
- DO NOT operate in a work area that has not been inspected for foreign debris and obstacles.
- Remove any foreign objects and clearly mark any objects that cannot be removed.
- Open bore holes must be capped and flagged.
- Drilling must be stopped in the event of the local thunderstorm or lightning activity.
- All rotating parts must be stopped before adding or removing bits and extensions.
- Wear safety glasses, gloves, hearing protection, and other protective clothing when required.
- At the completion of the useful life of the unit, drain all fluids and dismantle by separating the different materials (rubber, plastic, steel, etc.). Follow all federal, state, and local regulations for recycling and disposal of the fluid and components.

2. Safety

2.3 Safety Guidelines Cont'd

Machine Requirements and Capabilities

- The machine's operator's cab should be equipped with a thermoplastic polycarbonate or similar material front window, and similar protection on the sides of the operator's cab before operating the equipment.
- Augers shall be used only for their designed intent and shall not be loaded beyond their rated capacity. Overloading or exceeding the specifications dictated in this manual will void the warranty.
- Keep bystanders clear of moving parts and the work area. Keep children away.
- Do not exceed the maximum operating pressure. See "6.1 Attachment Specifications" on page 31.
- Use caution on slopes and near banks and ditches to prevent overturn.
- Travel only with the Auger in a safe transport position, such as tethering any auger bits and extensions connected to the drive with a chain, to prevent uncontrolled movement.
- Excavators used to power Augers must have their auxiliary circuit controlled with a variable foot control. This foot control gives the operator the ability to ease the power on and off, avoiding shock loading which will cause potential expensive damage to the hydraulic motor and gearbox.

Fire Prevention Safety

- Flammable debris (leaves, grass, etc.) must be removed regularly. If flammable debris is allowed to accumulate, it can cause a fire hazard. Clean often to avoid this accumulation.
- The equipment's hydraulic motor compartment must be inspected every day and cleaned if necessary to prevent fire hazards and overheating.
- All fuels, most lubricants, and some coolant mixtures are flammable. Flammable fluids that are leaking or spilled onto hot surfaces or onto

electrical components can cause a fire.

- Remove paint before welding or heating. Hazardous fumes/dust can be generated when paint is heated by welding, soldering or using a torch. Do all work outside or in a well ventilated area and dispose of paint and solvent properly. When sanding or grinding paint, avoid breathing the dust. Wear an approved respirator. If you use solvent or pain stripper, remove the stripper with soap and water before welding. Remove solvent or paint stripper containers and other flammable material from the area. Allow fumes to disperse at least 15 minutes before welding or heating.

Transporting Safety

- Comply with state and local laws governing highway safety and movement of machinery on public roads.
- Check local laws for all highway lighting and marking requirements.
- Always yield to oncoming traffic and move to the side of the road so any following traffic may pass.
- Never allow riders on either machine or equipment.
- If transporting the equipment on a truck or trailer, make sure the equipment is properly secured to the transport vehicle.

Hydraulic System

- Check hydraulic tubes, hoses, and fittings for damage and leakage. Never use open flame or bare skin to check for leaks. Hydraulic tubes and hoses must be properly routed and have adequate support and secure clamps. Tighten or replace any parts that show leakage.
- Always clean fluid spills. Do not use gasoline or diesel fuel for cleaning parts. Use commercial nonflammable solvents.
- Flow and pressure gauges, fittings, and hoses must have a continuous operating pressure rating of at least 25% higher than the highest pressures of the system.

2. Safety

2.3 Safety Guidelines Cont'd

Hydraulic System Cont'd

- This attachment is equipped with a hydraulic motor, which requires the oil to be of suitable cleanliness. Ensure the hoses are clear of any contamination during connecting and disconnecting to prevent contaminants entering the hydraulic motor.

Storage Safety

- Seal the hydraulic quick couplers from contaminants and secure all hydraulic hoses off the ground to help prevent damage.
- Clean the unit thoroughly, removing all mud, dirt, and grease.
- Inspect for visible signs of wear, damage, or breakage. Contact Blue Diamond® Product Support for ordering any parts required, and make necessary repairs to avoid delays upon removal from storage.
- Check that the drive unit motor and hoses are full of clean oil and planetary is full.
- Coat liberally with grease the output shaft and collar, extension shaft and collar, and all connecting pins to prevent rust and reduce wear.
- Tighten loose nuts, capscrews, and hydraulic connections.
- Replace safety decals that are missing or damaged.
- Store in a dry, sheltered place. Leaving the attachment outside will materially shorten its life.

Personal Protective Equipment



Proper Work Clothes: To help ensure your safety as a designated operator wear proper work clothes including tight fitting clothes, protective gloves, and shoes.



Hand Protection: To help ensure your safety as a designated operator wear protective gloves.



Protective Shoes: To help ensure your safety as a designated operator wear protective shoes.



Safety Helmet: To help ensure your safety as a designated operator wear a safety helmet.



Safety Helmet and Eye/Ear Protection: To help ensure your safety as a designated operator wear a safety helmet and eye/ear protection.

3. Operation

3.1 Pre–Operation Inspection

Before operating the Auger for the first time and each time thereafter, use the following list as a guideline during equipment inspection.



WARNING



AVOID SERIOUS INJURY OR DEATH

- Disengage machine’s auxiliary hydraulics, engage the machine’s parking brake, stop the engine, and make sure all moving parts are completely stopped before connecting, disconnecting, adjusting, or cleaning equipment.
- Always keep shields and guards in place when using the equipment.
- Disengage machine’s auxiliary hydraulics for road travel.
- Keep hands, feet, and clothing away from rotating parts.

- Lubricate the attachment per the schedule outlined in the Maintenance section. See “4.2 Gear Oil Change Schedule” on page 21.
- Check the mounting frame for damage or cracks.
- Check that all shields and guards are in place.
- Check for loose bolts, and tighten them if necessary.
- Check all welds on the attachment for wear and damage each time the attachment is removed from the machine.
- Check for damaged or missing safety decals. Replace if necessary.
- Inspect the machine’s mounting frame. (See the machine’s Operator’s Manual for inspecting the mounting frame.) Replace any parts that are damaged, bent, or missing. Keep all fasteners tight. Look for cracked welds.
- Verify that the Auger is properly connected to the machine.
- Check for damaged on pins, linkages, clips, bushes, and hood.
- Replace damaged parts.



WARNING



Leaking fluids under pressure can enter the skin and cause serious injury or death. Immediate medical attention is required.

Wear goggles. Use cardboard to check for leaks.

- Check the condition of all hydraulic components for leaks. Repair as required.

NOTE: Do not operate with hydraulic leaks.

3.2 Setup Procedure



IMPORTANT



Before the Auger is connected to the host machine, ensure that the drive is full of hydraulic oil and the gearbox is full of gear oil.

All Blue Diamond® Augers are shipped full of fluids (hydraulic and gearbox oil) unless specified otherwise in the form of a warning decal attached to the drive unit.

This decal is only applied in special circumstances, i.e. the attachment is shipped via air freight.

Once determined if the gearbox is sufficiently filled with oil, ensure the correct grade and quantity of oil is used. **DO NOT** run the drive unit without oil. Connect the hydraulic hoses.

All planetary gear drive units up to EX30HF use Chevrom Meropa ISO 320 (Mineral Oil) gearbox oil for operating in tropical ambient temperatures. See “4.3 How to Check the Gearbox Oil Level” for procedures on check the oil level of the gearbox as well as the gearbox oils recommended for cold climate conditions. Blue Diamond® offers many drive units with many different gear set ratios and, as a result, do not list every possible gearbox option and gearbox oil quantity required. See the Maintenance section, “4.2 Gear Oil Change Schedule” on page 21 for gearbox volume and checking and topping of the gearbox oil.

3. Operation

3.2 Setup Procedure Cont'd

NOTE: To ensure best motor life, run the motor for approximately one hour at 30% of rated pressure before application to full load. Be sure that motor and gearbox are full of fluids prior to any load application.

NOTE: When procuring any hose assemblies for use on the Auger, ensure that the maximum operating pressure of the hoses is always higher than what the machine can produce.

3.3 Entering and Exiting the Host Machine

 **IMPORTANT** 



See the machine's Operator's Manual for detailed information on operating the loader.

Entering the Operator's Position

Use the attachment safety treads, handles, and steps (on the machine) to enter the operator's position.

When in the operator's position, lower safety seat bar, start the engine, and release the parking brake.

Leaving the Operator's Position



WARNING



AVOID SERIOUS INJURY OR DEATH

- Always park on a flat, level surface.
- Lower lift arms, and place attachment flat on the ground.
- Place all controls in **NEUTRAL**.
- Engage the park brake.
- Stop the engine, and remove the key.
- Wait for all moving parts to stop.

SEE MACHINE'S OPERATOR'S MANUAL FOR ADDITIONAL INFORMATION.

Park the machine / attachment on a flat, level surface.

Place all controls in neutral, engage the park brake, stop the engine, and wait for all moving parts to stop. Leave the operator's position.

3. Operation

3.4 Attachment Installation with Skid Steer

Connecting Attachment To The Machine



WARNING



CRUSH HAZARD

- Before moving the machine, look in all directions and make sure no bystanders, especially small children are in the work area.
- Do not allow anyone between the machine and attachment when approaching the attachment for connecting.
- Keep fingers and hands out of pinch points when connecting and disconnecting the attachment.

Before connecting to the attachment, inspect the machine's mounting plate. (See the machine's Operator's Manual for inspecting the mounting frame.)

Enter the operator's position. See "Entering the Operator's Position" on page 12.

Drive the machine slowly forward, until the top edge of the machine's mounting plate is under the top flange of the attachment mounting frame.

Slowly tilt the machine's mounting plate back until the attachment mounting frame fully contacts the front of the machine's mounting plate.

Leave the operator's position. See "Leaving the Operator's Position" on page 12.



WARNING



AVOID SERIOUS INJURY OR DEATH

The locking pins / wedges must extend through the holes in the attachment mounting frame. Failure to secure locking pins / wedges can allow attachment to come off.

SEE MACHINE'S OPERATOR'S MANUAL FOR ADDITIONAL INFORMATION.

Engage attachment locking levers / wedges (See the machine's Operator's Manual for detailed information).

Connecting Hydraulic Hoses



IMPORTANT



Thoroughly clean the quick couplers before making connections. Dirt can quickly damage the hydraulic system.

Remove dirt or debris from the male and female couplers. Visually inspect the couplers for corroding, cracking, damage, or excessive wear. Replace as needed.

Connect the attachment hydraulic hoses to the machine.

Pull on each hose to verify full connection is made.

Disconnecting Hydraulic Hoses



WARNING



Leaking fluids under pressure can enter the skin and cause serious injury or death. Immediate medical attention is required. Wear goggles. Use cardboard to check for leaks.

Relieve auxiliary hydraulic pressure. (See the machine's Operator's Manual for correct procedure.)

Disconnect attachment hydraulic hoses from the machine.

3. Operation

3.4 Attachment Installation with Skid Steer Cont'd

Disconnecting Attachment From the Machine

Relieve auxiliary hydraulic pressure. (See the machine's Operator's Manual for correct procedure.)

Park the machine and attachment on a flat level surface. Lower the attachment flat on the ground.

Leave the operator's position. See "Leaving the Operator's Position" on page 12.

Disconnect attachment hydraulic hoses from the machine.

Disengage locking pins / wedges. (See the machine's Operator's Manual for correct procedure.)

Enter the operator's position. See "Entering the Operator's Position" on page 12.

Slowly tilt the machine's mounting plate forward until the attachment mounting frame is free from the machine's mounting plate.

Drive the machine slowly backward, away from the attachment.

3.5 Attachment Installation with Excavator

Connecting Attachment to the Machine



WARNING



AVOID SERIOUS INJURY OR DEATH

The locking pins / wedges must extend through the holes in the attachment mounting frame. Failure to secure locking pins / wedges can allow attachment to come off.

SEE MACHINE'S OPERATOR'S MANUAL FOR ADDITIONAL INFORMATION.

Order the appropriate bracket interchange from your local Blue Diamond® Attachments dealer by supplying the brand and model information of your machine.

The bracket interchange is secured to the attachment with bolts.

Use an appropriate lifting device and slings to place the bracket interchange onto the attachment.

Align the holes between the bracket interchange and deck and install the appropriate hardware.

Torque hardware to the specification detailed in the "6.2 Torque Specifications" on page 32.

Position the excavator at the rear of the attachment.

Extend the tool cylinder and paddle until the pin position is aligned.

Leave the operator's position. See "Leaving the Operator's Position" on page 12.

Install the pin through the attachment and paddle and secure with appropriate hardware.

3. Operation

3.5 Attachment Installation with Excavator Cont'd

Connecting Attachment to the Machine Cont'd

Enter the operator's position. See "Entering the Operator's Position" on page 12.

Adjust the height of the dipperstick to align with the pin position.

Leave the operator's position. See "Leaving the Operator's Position" on page 12.

Install the pin through the attachment and paddle and secure with appropriate hardware.

Connecting Hydraulic Hoses



Thoroughly clean the quick couplers before making connections. Dirt can quickly damage the hydraulic system.

Remove dirt or debris from the male and female couplers. Visually inspect the couplers for corroding, cracking, damage, or excessive wear. Replace as needed.

Connect the attachment hydraulic hoses to the machine.

Pull on each hose to verify full connection is made.

Disconnecting Hydraulic Hoses



AVOID SERIOUS INJURY OR DEATH
Hydraulic fluid, tubes, fittings, and quick couplers can get hot during operation. Be careful when connecting and disconnecting hydraulic hoses.

Relieve auxiliary hydraulic pressure. (See the machine's Operator's Manual for correct procedure).

Disconnect attachment hydraulic hoses from the machine.



Leaking fluids under pressure can enter the skin and cause serious injury or death. Immediate medical attention is required. Wear goggles. Use cardboard to check for leaks.

Disconnecting Attachment From the Machine

Relieve auxiliary hydraulic pressure. (See the machine's Operator's Manual for correct procedure.)

Park the machine and attachment on a flat level surface. Lower the attachment flat on the ground.

Leave the operator's position. See "Leaving the Operator's Position" on page 12.

Disconnect attachment hydraulic hoses from the machine.

Remove hardware securing the pins and remove the pins from the paddle and attachment.

Enter the operator's position. See "Entering the Operator's Position" on page 12.

Raise the dipperstick to clear the attachment.

Drive the machine slowly backward, away from the attachment.

3. Operation

3.6 Installing Bits & Extensions to the Auger Drive

Before connecting the bit and / or extension to the auger, make sure that the auger teeth and pilots are not worn. Ensure all worn parts are replaced. Worn parts will become ineffective and severely diminish the overall performance of the attachment.

1. Lay the attachment down so it is parallel with the ground.
2. Tilt the auger drive up so the output shaft is at the approximate angle needed to install the auger bit or extension.

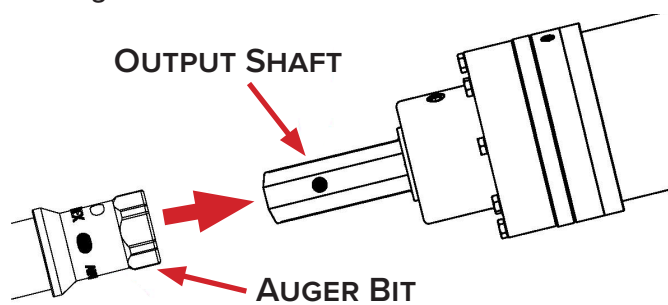

Figure 1

3. Raise the auger, and line the pin holes in the bit or extension and the output shaft. Slide the bit onto the shaft until the holes are aligned.

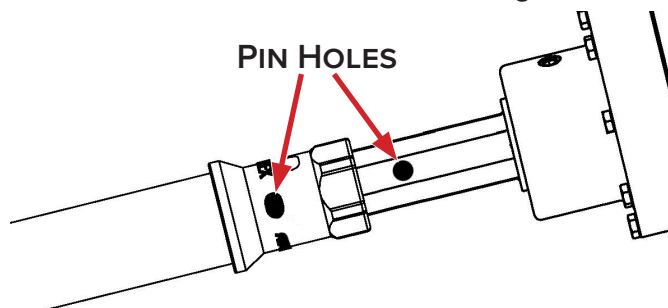

Figure 2

4. Insert the bolt through the auger bit or extension and the output shaft. Tighten the nut per torque values on page 32.

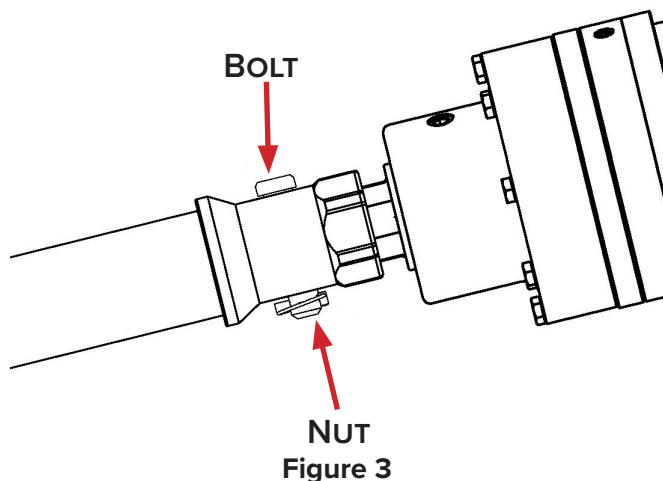

Figure 3

3.7 Cold Weather Startup Information

The information that is in this section is an aid to the operation and maintenance of your Blue Diamond® Auger in cold weather. When operating in temperatures from 48°F (9°C) to -40°F (-40°C), refer to the host machine's Operator's Manual for best practices.

Be sure to read the information for selecting the correct oils for use in cold weather. Refer to page 21 for detail. Prepare the host machine for weather conditions as instructed in the machine's Operator's Manual.

Blue Diamond's Auger is designed to operate within air temperature of 41°F (5°C) and 86°F (30°C).

For temperatures below 41°F, it is recommended to slowly start the drive under no load at minimum speed. This will allow warm hydraulic oil from your host machine to circulate through the hydraulic motor of your drive and slowly bring it to the minimum recommended operating temperature of 41°F.

Once the minimum temperature has been achieved, slowly introduce load to the output of the drive unit, which, in turn, will increase the internal gear oil temperature.

3. Operation

3.7 Cold Weather Startup Information Cont'd

The host machine's cooling system and lubrication system for the engine do not lose heat immediately upon shutdown. The transmission and hydraulic system lose heat more rapidly because of more exposed areas. The planetary gearbox and motor cases cool rapidly, since the cases do not operate as warm as other compartments. Therefore, after any period of down time on the machine, be sure to achieve full operating temperatures through the following startup instructions. Thick oil can cause high case pressures, which, in turn, can cause shaft seal problems.

3.8 Operating the Attachment



IMPORTANT

The Extreme Duty Series 2 Auger Drive is specifically designed for drilling and rotational operation only. Do not use the attachment for lifting purposes.

This attachment is designed for drilling vertical or horizontal holes or rotating piers into the ground. Use in any other way is considered contrary to the intended use.

After all installation instructions have been completed, all information in 2.0 Safety has been read and understood, and the rest of this operator's manual have been reviewed, the Auger is now ready for use.

1. With the auger bit raised off the ground and the vehicle engine set at a low RPM, activate the host machine's drive control valve to determine which position the control valve lever must be in to turn the bit in a forward (clockwise) rotation. This is the "digging" position.
2. Before beginning to dig, experiment with the auger speed to determine a suitable RPM. Generally in light and sandy soil, a high RPM is desirable. In a hard, rocky, or frozen soils, a slower RPM is desirable. To increase auger

RPM, increase the host machine's engine RPM. To decrease the auger RPM, decrease the host machine's engine RPM.

3. Raise the attachment so the auger bit hangs vertically and the drive is clear of the cradle. Then lower the bit into the starting position.
4. Ensure the mount plate on your machine is forward and not back. This will keep the auger clear of the cradle and allow the bit to move freely from side to side and forward and back. The pendulum action must not be hindered otherwise damage and / or bending of the output shaft or bit may occur. Lower the bit into the ground, ensuring the drive does not stall and remains in a vertical position, start the rotation of the Auger.
5. As the bit starts to load up with material (soil, rock, sand, etc.), stop the rotation whilst still in the hole, and raise the bit vertically. Move away from the hole, and rotate the Auger in a forward direction to remove the material.
6. If experiencing strong resistance while trying to remove the bit when it is full of material, reverse the auger slowly while raising the bit vertically to assist with removal. Do not use the host machine to pull as this increases the risk of bending the output shaft.
7. Keep clearing the hole regularly during operation. This will help prolong the life of the attachment as well as wear parts.

NOTE: Blue Diamond® recommends adding a slow stream of water when drilling rock to help the performance and life of the rock teeth.



IMPORTANT

- **DO NOT** rapidly switch between forward and reverse operation to remove material from the Auger. This creates excessive pressure spikes, which will adversely affect performance and longevity of the motor.
- Do not remove the bit from the hole while at an angle. This will increase the risk of bending the auger bit or output shaft.
- Do not flick material, especially mud or clay, from the bit as this increases the risk of bending the output shaft.

3. Operation

3.9 Skid Steer Operating Positions

Drilling Position

Ensure the vertical position is maintained when drilling.

DO NOT drill with the cradle resting against the drive unit. This will damage the drive unit and auger.

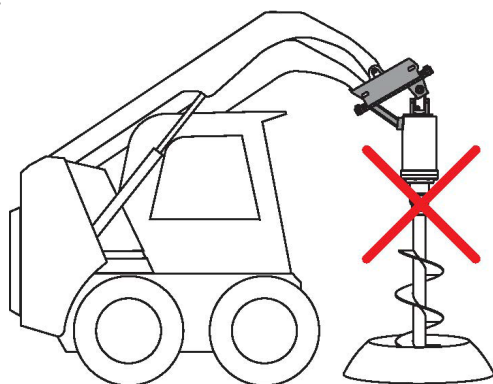

Figure 4

The correct drilling operation is with the cradle positioned up and away from the drive unit, allowing the drive and auger to swing freely left, right, forward, and backward.

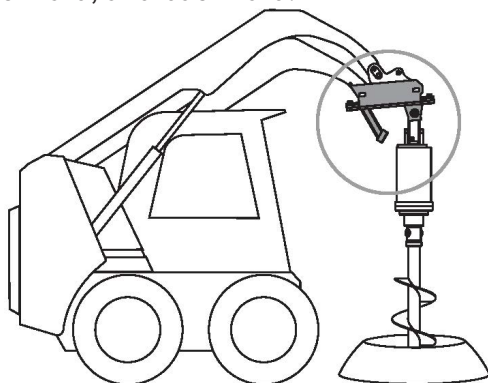

Figure 5

Travel Position

For maneuvering around the work area, the cradle must be positioned so the drive unit is resting against the cradle arm and the machine's loader arms are not obstructing visibility.

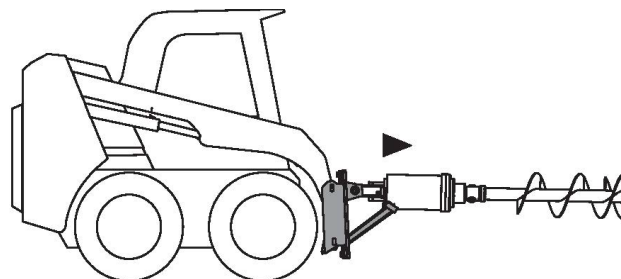

Figure 6

3. Operation

3.10 Excavator Operating Positions

For excavators, apply the greatest amount of down force from the main boom. Be aware that the boom moves in an arc. To maintain a plumb drilling position, you will need to compensate for this movement by adjusting the dipper arm or moving the machine backwards or forwards to ensure the bit is drilling straight. Take extreme care when doing this to prevent the auger or screw pile from bending or pulling flights against the inside of the holes.

Drilling Position

The drive unit must hang free when drilling. The mount is designed to handle torsional loads of anchors.

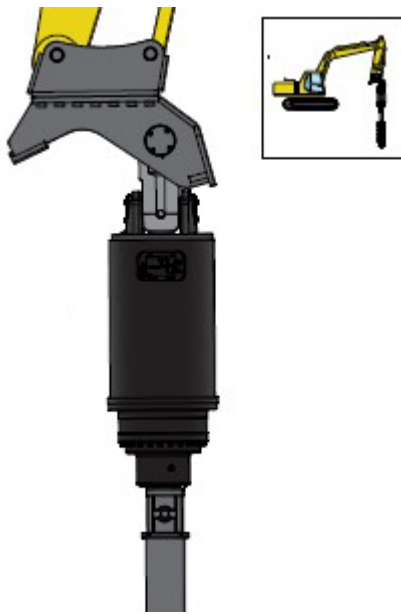

Figure 7

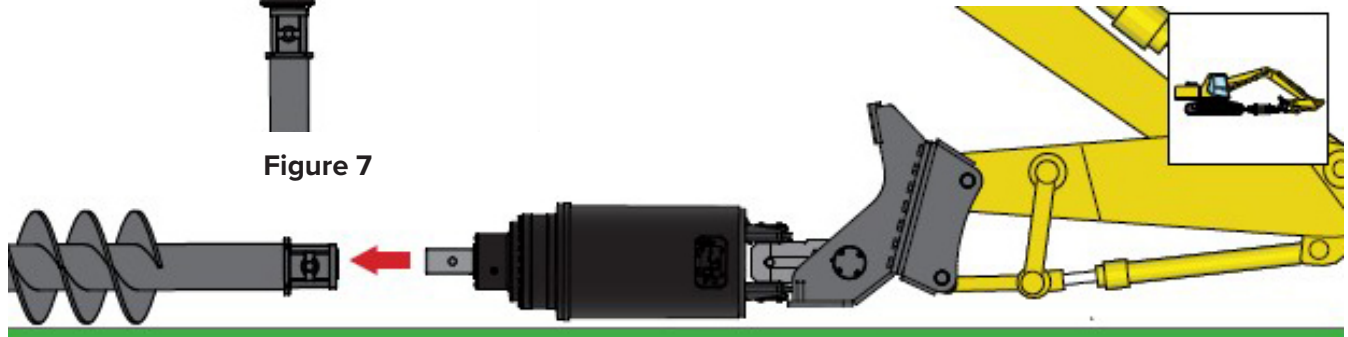

Figure 9

Transport Position

The rear cradle stops the auger and prevent the bit from swinging around while maneuvering around the work area.

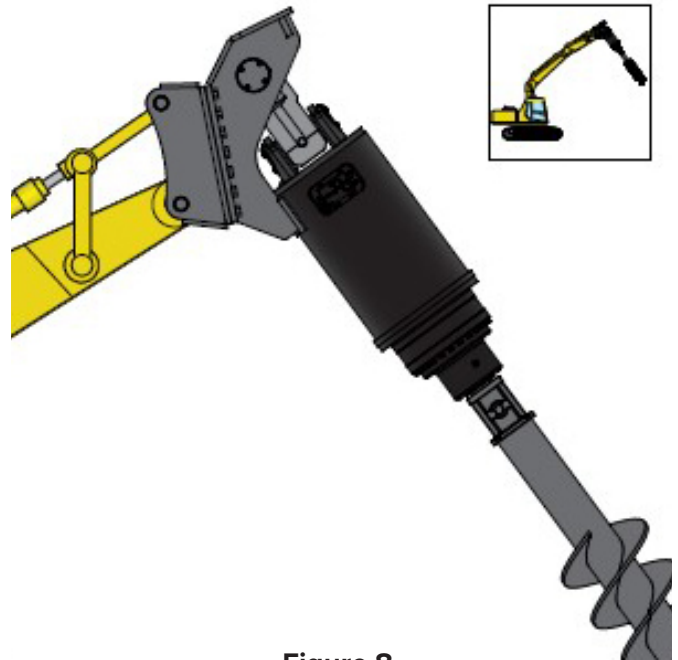

Figure 8

Bit Connection

The front cradle allows the operator to angle the drive up to 90 degrees for easy connection to bits and extensions. See Figure 9.

4. Maintenance

4.1 Service Schedule

| DESCRIPTION | SERVICE PROCEDURES | | | | | |
|---|--------------------|-------|------|--------|--------|-------|
| | Check | Clean | Lube | Change | Adjust | Drain |
| Daily Maintenance (or every 8 hours) | | | | | | |
| Hydraulic Fittings | • | | | | | |
| Hydraulic Hoses | • | | | | | |
| Bits (teeth, retaining bolt, etc.) | • | • | | | | |
| All Hardware | • | | | | | |
| Weekly Maintenance (or every 40 hours) | | | | | | |
| All Hardware | • | | | | | |
| Monthly Maintenance | | | | | | |
| All Hardware | • | | | | | |
| 500 Hour Maintenance | | | | | | |
| Gear Oil* | | | | • | | |

*See “4.2 Gear Oil Change Schedule” on page 21 for more information.

4. Maintenance

4.2 Gear Oil Change Schedule

Gearbox oil capacity is engraved on the serial tag located on the top of the hood.

Blue Diamond® recommends Chevron Meropa ISO 32 Mineral Oil for gear oil. Minimum operating temperature is -0.4°F (-18°C), and the maximum operating temperature is 225°F (107°C).

If operating in weather conditions are below 41°F (5°C), see “3.7 Cold Weather Startup Information” on page 16.

Moderate Operating Conditions

- The first oil change must occur after the first 50 hours of operation.
- After the initial oil change, the oil will need changed every 500 hours of operation or once every 12 months, whichever comes first.

Severe Operating Conditions

- When environment temperature is below 32°F (0°C) or above 104°F (40°C) or the auger is being used in hard ground or for extended and continuous hours, this is considered Severe Operating Conditions.
- The first oil change must occur after the first 30 hours of operation.
- After the initial oil change, the oil will need changed every 300 hours of operation or once every 12 months, whichever comes first.

| DESCRIPTION | OIL CAPACITY | RECOMMENDED OIL |
|-------------|------------------------------|-----------------------|
| EX1 | 0.58 Quarts (0.55 Liters) | EPG320 Mineral Oil |
| EX2 | | |
| EX3 | | |
| EX4 | | |
| EX4HF | 0.85 Quarts (0.8 Liters) | |
| EX5HF | 1.53 Quarts (1.45 Liters) | |
| EX6HF | | |
| EX7HF | | |
| EX9HF | 2.64 Quarts (2.5 Liters) | |
| EX12HF | | |
| EX13HF | 3.38 Quarts (3.2 Liters) | |
| EX16HF | | |
| EX20HF | 5.1 Quarts (4.8 Liters) | |
| EX25HF | | |
| EX30HF | | |

4. Maintenance

4.3 How to Check the Gearbox Oil Level

Unfortunately, there is no procedure to quickly inspect the gearbox oil level. The gearbox is filled to the correct level during manufacturing.

Unless there are clear signs of gearbox oil leakage, the attachment should not require additional oil prior to scheduled oil changes and / or services.

4.4 How to Drain Gearbox Oil

The gearbox oil change interval should be carried out in accordance with the requirements set out in “4.2 Gear Oil Change Schedule” on page 21. Blue Diamond® recommends to replace the output shaft seal during the initial oil change as this is the most important oil change to prolong the life of bearings and gears. This is because gearboxes can generate fine, metallic contamination, which can will find its way to the lowest part of the gearbox and collect in the output seal. This abrasive paste will wear the output seal and the output shaft. It is advisable that the oil changes are performed by a local Blue Diamond® authorized dealer. If one is not available, it is more important that the oil is changed at the required intervals.

Follow all local, state, and federal laws when disposing of oil.



WARNING



AVOID SERIOUS INJURY OR DEATH

- Disengage machine’s auxiliary hydraulics, engage the machine’s parking brake, stop the engine, and make sure all moving parts are completely stopped before connecting, disconnecting, adjusting, or cleaning equipment.
- Ensure that the gearbox is stable, secure, and safe to work on.
- The drive unit must be vertical.
- An appropriately sized drip tray is placed to catch the drained oil.

4.5 How to Change or Refill the Gearbox Oil

Use the correct oil. See “4.2 Gear Oil Change Schedule” on page 21.

1. Lay the drive unit flat on the ground with the oil fill plug facing up. Using an 8 mm Allen key, remove the plug.

To drain the oil, turn the drive until the hole is facing down. Allow to drain until all oil has been removed.

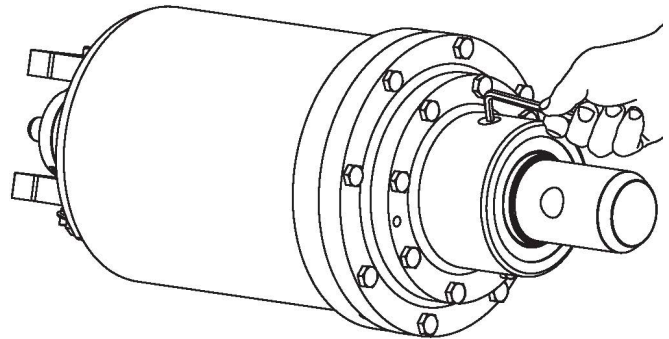

Figure 10

2. Rotate the unit until the oil fill hole is sitting between 60° and 70° from horizontal.

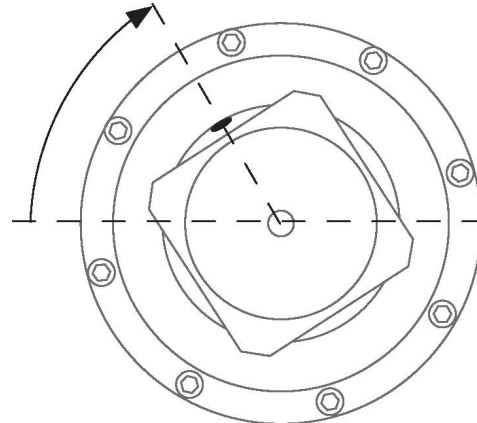

Figure 11

4. Maintenance

4.5 How to Change or Refill the Gearbox Oil Cont'd

- Once the oil fill hole is at approximately 60°, the oil should be sitting at the base of the oil fill hole.

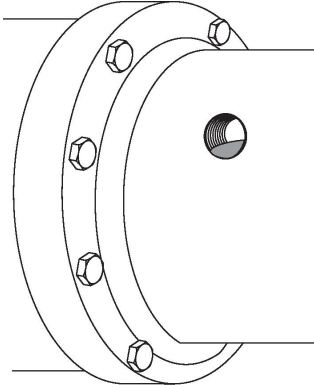

Figure 12

- If the oil is too low to reach the thread, it should be topped off. Rotate the unit so the oil fill hole is sitting at the top, and add oil.

Repeat steps 2 – 4 until the correct level is achieved.

NOTE: The oil takes time to work its way through the gearbox. Allow time for it to settle once it has reached the oil fill hole. Then check the level again until all seepage has occurred.

! IMPORTANT !

If the auger is leaking oil after performing the daily checks, contact Blue Diamond® Product Support or a local authorized dealer.

4.6 How to Replace Teeth on Auger Bits



WARNING



AVOID SERIOUS INJURY OR DEATH

- Always wear safety glasses and other appropriate personal protective equipment (PPE), such as gloves, when replacing teeth on auger bits due to risk of flying objects.

Position the bit so that the bottom is easily accessible. Ensure it is firmly secured to prevent injury and / or damage to the equipment.

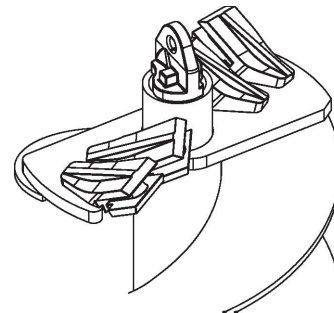

Figure 13

Pilot

- Remove the nut and bolt from the pilot. Then remove the pilot.
- Clean the bit.
- Place the pilot on the bottom of the bit, and secure with nut and bolt.

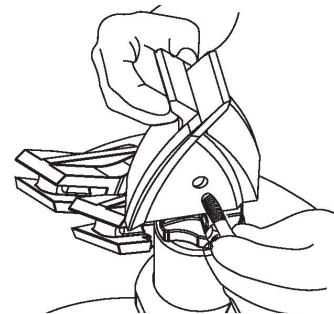

Figure 14

4. Maintenance

4.6 How to Replace Teeth on Auger Bits Cont'd

Cast Head Teeth

1. To remove the old tooth, place a pin punch at the back of the tooth.
2. Using a hammer or mallet, tap the punch until the tooth is removed.
3. Clean the tooth holder.
4. Place the rubber locking strip into the tooth holder with the fold facing out. See Figure 15 and Figure 16.



Figure 15



Figure 16

5. Place the tooth in the tooth holder, ensuring the tooth's cutting edge is facing the same direction as the pilot. See Figure 17.



Figure 17

6. Using a soft head mallet, drive the tooth in the holder until it is fully seated. If a soft mallet is not available, a piece of wood can be used between the tooth and the mallet. See Figure 18.



WARNING



AVOID SERIOUS INJURY OR DEATH

- DO NOT strike the tip of the auger tooth directly with a steel hammer. This can cause the hardened or tungsten carbide tip to shatter.



Figure 18

7. Repeat until all teeth are replaced as necessary.

4. Maintenance

4.6 How to Replace Teeth on Auger Bits Cont'd

Fab Head & Tree Bit Teeth

1. Using a wrench, loosen the bolt that is holding the worn tooth in place.
2. Once the bolt is removed, remove the worn tooth from the bit.
3. Clean the tooth holder.
4. Align the new tooth with the bolt hole.
5. Tighten the bolt to the torque specified in "6.2 Torque Specifications" on page 32.
6. Repeat until all teeth are replaced as necessary.

Rock Bit Teeth

1. Place a tooth removal tool in the groove of the tooth. Use a soft hammer to tap on the removal tool.

Alternatively, if not equipped with a tooth removal tool, place a pin punch or center punch against the tooth at the back of the tooth holder, and drive the tooth out from behind.

2. Once the old tooth is removed, clean the tooth holder.
3. Place the rock bit tooth in the holder, and use to soft head mallet to tap it into place. The new tooth is in place when it is seated all the way back in the tooth holder.

Alternatively, if not equipped with a tool removal tool, place a piece of wood or pipe on the end of the tooth for protection.

4. Make sure the tooth rotates with no resistance.
5. Repeat until all teeth are replaced as necessary.

4.7 Maintaining Auger Bits

The Auger Bit is a ground-engaging tool fitted with wear parts to dig holes. Therefore, the bit's teeth and pilot must be check regularly and replaced with new wear parts. Failure to do so will cause premature wear and damage to the auger pocket and flighting and will substantially reduce the drilling performance of the auger bit.

Be sure to clean the auger bit after each use. If not cleaned, the dirt and dust can prevent rotation and cause premature wear.

4. Maintenance

4.8 Troubleshooting

| PROBLEM | CAUSE | SOLUTION |
|--------------------------|---|---|
| GENERAL | | |
| No Rotation | Quick disconnect fitting(s) not engaged | Check quick disconnect fitting(s). |
| | Quick disconnect fitting(s) faulty | Replace faulty fittings. |
| | Hydraulic oil tank low | Fill oil tank to the maximum level. |
| | Hydraulic motor failure | Contact Blue Diamond® Product Support. |
| | Output shaft bearing failure | Contact Blue Diamond® Product Support. |
| | Planetary gear failure | Contact Blue Diamond® Product Support. |
| | Machine oil pump faulty | Refer to the machine's Operator's Manual. |
| Slow Rotation | Low oil flow | Check the machine's specifications. |
| | Drive unit too large for the machine | Contact Blue Diamond® Product Support. |
| | Hydraulic system too hot | See Hydraulic System Section. |
| Hood Leaking Oil | Hose(s) or fitting(s) leaking | Tighten or replace. |
| | Motor O-ring failure | Contact Blue Diamond® Product Support. |
| Output Shaft Leaking Oil | Oil seal failure | Contact Blue Diamond® Product Support. |
| | Hydraulic motor failure | Contact Blue Diamond® Product Support. |
| No Torque | Oil pressure too low | Check the machine's specifications. |
| | Drive unit too small for the machine | Contact Blue Diamond® Product Support. |
| | Hydraulic system too hot | See Hydraulic System Section. |
| Grinding or Loud Noise | Gearbox failure | Contact Blue Diamond® Product Support. |
| HYDRAULIC SYSTEM | | |
| Oil Overheating | Oil pressure too low | Set relief valve to the machine's specifications. |
| | Restriction in line | Inspect and repair. |
| | Auger continually stalling | Limit down pressure. |
| | Drive unit too small | Contact Blue Diamond® Product Support. |
| | Machine too small | Fit the drive unit to a larger machine. |
| | Hydraulic oil tank low | Fill oil tank to maximum level. |
| | Insufficient oil capacity | Fit oil cooler. |
| BITS | | |
| Slow Digging Speed | Worn teeth or pilot | Replace. (See "4.6 How to Replace Teeth on Auger Bits" on page 23.) |
| | Ground too hard | Contact Blue Diamond® Product Support. |
| | Low oil flow | Check the machine's specifications. |
| | Bit too large for drive unit | Fit larger drive unit. |
| | Machine too small | Fit drive unit to a larger machine. |

5. Parts

5.1 Main Components — EX1

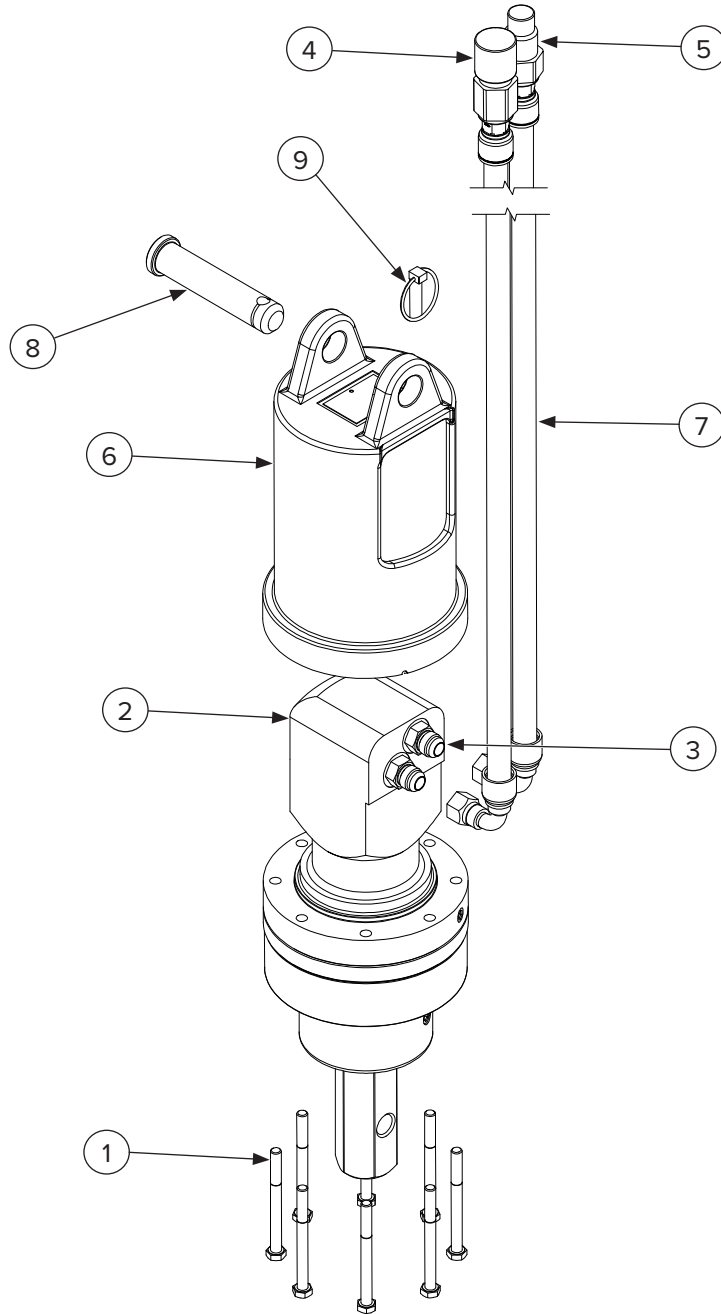

| ITEM | PART NUMBER | DESCRIPTION | QTY |
|------|----------------------|--|-----|
| 1 | 299014 | Bolt Hex M10 X 110 G8.8 Zinc Plated | 8 |
| 2 | — | Motor and Gearbox Assembly | 1 |
| 3 | — | Straight Fitting Male #10 JIC to Male #10 O-Ring Boss | 2 |
| 4 | 224011 | Female Coupler 1/2" Body Flat Face #12 O-Ring Boss Thread | 1 |
| 5 | 224012 | Male Coupler 1/2" Body Flat Face #12 O-Ring Boss Thread | 1 |
| 6 | — | Hood | 1 |
| 7 | 295010-M10ORB-M10JIC | Hydraulic Straight Fitting Male #10 O-Ring Boss x Male #10 JIC | 2 |
| 8 | 205765 | Pin 29.7 – 150mm OAL, 146mm SL, 29.7mm Diameter (Includes Item #9 Lynch Pin) | 1 |
| 9 | 205785 | Lynch Pin, 11 mm Shaft | 1 |

5. Parts

5.2 Main Components – EX2, EX3, & EX4

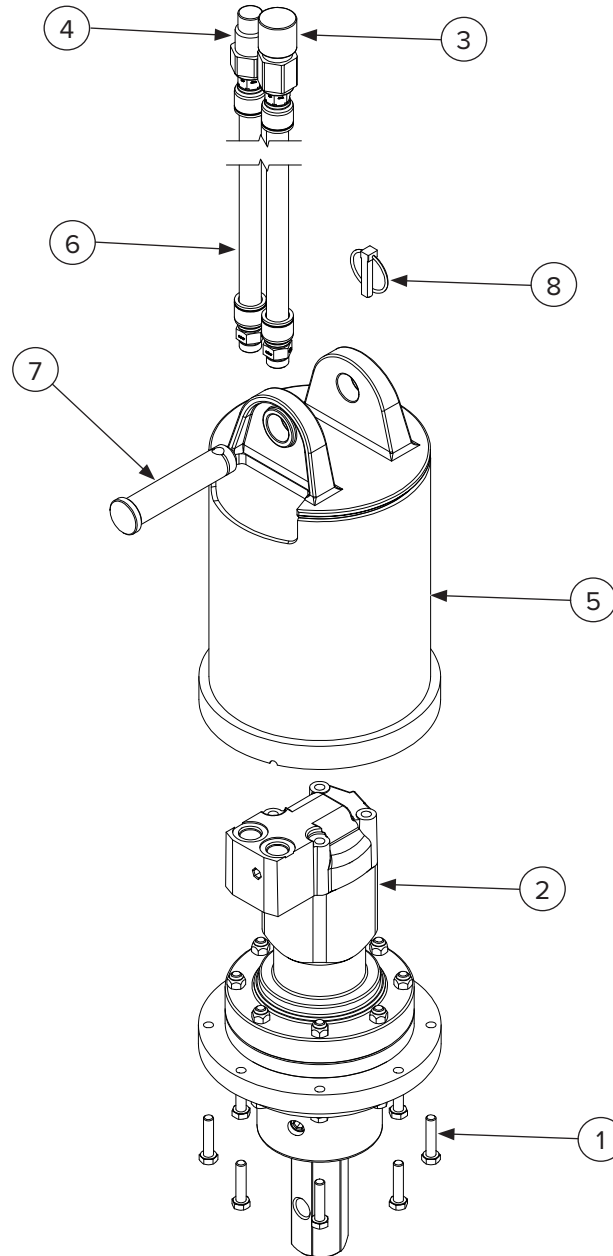

| ITEM | PART NUMBER | DESCRIPTION | EX2 QTY | EX3 QTY | EX4 QTY |
|------|-------------|--|---------|---------|---------|
| 1 | 299017 | Bolt Hex M10 X 45 G8.8 Zinc Plated | 8 | 8 | 8 |
| 2 | — | EX2 Motor and Gearbox Assembly | 1 | — | — |
| | 205600 | EX3 Motor and Gearbox Assembly | — | 1 | — |
| | 205771 | EX4 Motor and Gearbox Assembly | — | — | 1 |
| 3 | 224011 | Female Coupler 1/2" Body Flat Face #12 O-Ring Boss Thread | 1 | 1 | 1 |
| 4 | 224012 | Male Coupler 1/2" Body Flat Face #12 O-Ring Boss Thread | 1 | 1 | 1 |
| 5 | 205521 | Hood | 1 | 1 | 1 |
| 6 | 231000 | Machine Hose 87" OAL 1/2" ID Straight Male #8 O-Ring Boss Both Ends | 2 | 2 | 2 |
| 7 | 205765 | Pin 29.7 – 150mm OAL, 146mm SL, 29.7mm Diameter (Includes Item #8 Lynch Pin) | 1 | 1 | 1 |
| 8 | 205785 | Lynch Pin, 11 mm Shaft | 1 | 1 | 1 |

5. Parts

5.3 Main Components – EX4HF

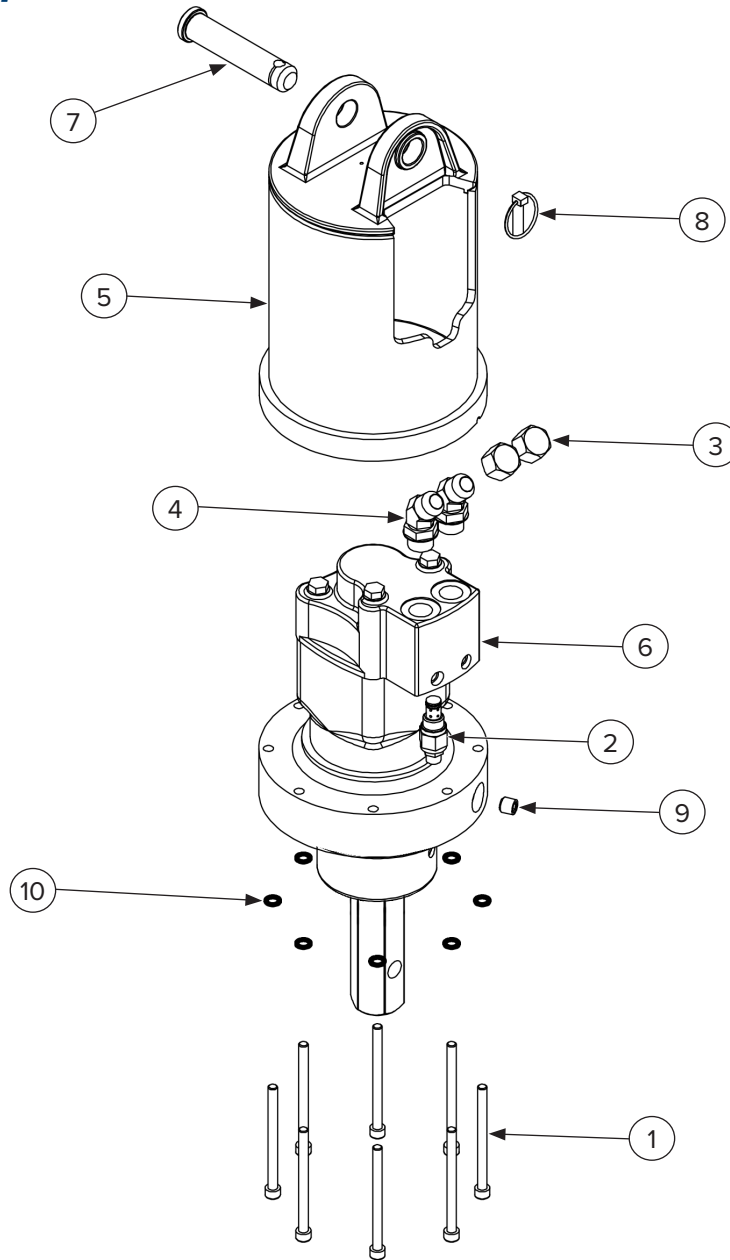

| ITEM | PART NUMBER | DESCRIPTION | QTY |
|------|----------------------|--|-----|
| 1 | 299037 | M10 x 130 Screw Socket Head Cap Zinc Plated | 8 |
| 2 | — | Relief Valve Cartridge | 1 |
| 3 | 295014-F12JIC | #12 JIC Cap Nut | 2 |
| 4 | 295020-M12JIC-M12ORB | Hydraulic 45 Degree Fitting Male #12 JIC x Male #12 O-Ring Boss | 2 |
| 5 | 205795 | Hood | 1 |
| 6 | — | Motor and Gearbox Assembly | 1 |
| 7 | 205765 | Pin 29.7 – 150mm OAL, 146mm SL, 29.7mm Diameter (Includes Item #8 Lynch Pin) | 1 |
| 8 | 205785 | Lynch Pin, 11 mm Shaft | 1 |
| 9 | 205519 | Pressure Plug 3/8 BSPT | 2 |
| 10 | 299100 | M10 Washer Wedge Lock | 8 |

5. Parts

5.4 Safety Decals

1
2



4



6



3



4



5



| ITEM | PART NUMBER | DESCRIPTION | EX1 QTY | EX2 QTY | EX3 QTY | EX4 QTY | EX4HF QTY |
|------|-------------|--|---------|---------|---------|---------|-----------|
| 1 | BD-111 | 7.75" x 6.0" Decal, Blue Diamond Attachments | 1 | — | — | — | 1 |
| 2 | BD-060 | 2.4375" x 3.375" Decal, Blue Diamond Attachments | — | 1 | 1 | 1 | — |
| 3 | BD-001 | 3.0" x 3.0" Decal, Read Owner's Manual | 1 | 1 | 1 | 1 | 1 |
| 4 | BD-092 | 1.5" x 2.0" Decal, Warranty Registration QR | 1 | 1 | 1 | 1 | 1 |
| 5 | BD-058 | 1.0" x 6.5" Decal, Extreme Duty | 1 | 1 | 1 | 1 | 1 |
| 6 | — | Caution, High Pressure Fluid Hazard | 1 | 1 | 1 | 1 | 1 |

6. Specifications

6.1 Attachment Specifications

| DESCRIPTION | EX1 | EX2 | EX3 | EX4 | EX4HF |
|---|--------------------|---------|---------|---------|-----------------------|
| Torque (ft / lb) @ 3,000 PSI | 1,467 | 2,254 | 2,829 | 3,275 | 3,583 |
| Maximum Torque (ft / lb) @ 3,500 PSI | 1,712 | 2,630 | 3,300 | 3,821 | 4,180 |
| Recommended Flow (GPM) | 6 – 16 | 10 – 26 | 10 – 30 | 10 – 30 | 10 – 36 |
| Peak Efficiency (GPM) | 8 – 11 | 12 – 16 | 17 – 20 | 19 – 23 | 21 – 26 |
| Motor Type | Eaton | | | | |
| Maximum Pressure (DO NOT EXCEED) | 3,500 PSI @ 16 GPM | | | | 3,500 PSI @ 27 GPM |
| Maximum Flow (DO NOT EXCEED) | 30 GPM @ 1,800 PSI | | | | 42 GPM @ 2,250 PSI |
| Maximum Horsepower (HP) | 33 | | | | 55 |
| Pressure Relief Valve | NO | | | | YES |
| Output Shaft | 2.0" Hex | | | | |
| Maximum Drilling Diameter Clay / Shale (in.) | 12 | 24 | | | |
| Maximum Drilling Diameter Earth (in.) | 24 | 30 | | | 40 |
| Weight (lbs) | 101 | 123 | | 125 | 180 |
| Overall Length (in.) | 24 1/2 | 26 | | | 29 |
| Diameter (in.) | 7 1/2 | 9 1/2 | | | |

6. Specifications

6.2 Torque Specifications

Standard Hardware and Lock Nuts

| BOLT TYPE | CLASS 4.8 | | CLASS 8.8 OR 9.8 | | CLASS 10.9 | | CLASS 12.9 | |
|-----------|------------|-------------|------------------|-------------|-------------|-------------|-------------|-------------|
| | Lubricated | Dry | Lubricated | Dry | Lubricated | Dry | Lubricated | Dry |
| M6 | 4.8 N•m | 6 N•m | 9 N•m | 11 N•m | 13 N•m | 17 N•m | 15 N•m | 19 N•m |
| | 3.5 lbf•ft | 4.5 lbf•ft | 6.5 lbf•ft | 8.5 lbf•ft | 9.5 lbf•ft | 12 lbf•ft | 11.5 lbf•ft | 14.5 lbf•ft |
| M8 | 12 N•m | 15 N•m | 22 N•m | 28 N•m | 32 N•m | 40 N•m | 37 N•m | 47 N•m |
| | 8.5 lbf•ft | 11 lbf•ft | 16 lbf•ft | 20 lbf•ft | 24 lbf•ft | 30 lbf•ft | 28 lbf•ft | 35 lbf•ft |
| M10 | 23 N•m | 29 N•m | 43 N•m | 55 N•m | 63 N•m | 80 N•m | 75 N•m | 95 N•m |
| | 17 lbf•ft | 21 lbf•ft | 32 lbf•ft | 40 lbf•ft | 47 lbf•ft | 60 lbf•ft | 55 lbf•ft | 70 lbf•ft |
| M12 | 40 N•m | 50 N•m | 75 N•m | 95 N•m | 110 N•m | 140 N•m | 130 N•m | 165 N•m |
| | 29 lbf•ft | 37 lbf•ft | 55 lbf•ft | 70 lbf•ft | 80 lbf•ft | 105 lbf•ft | 95 lbf•ft | 120 lbf•ft |
| M14 | 63 N•m | 80 N•m | 120 N•m | 150 N•m | 175 N•m | 225 N•m | 205 N•m | 260 N•m |
| | 47 lbf•ft | 60 lbf•ft | 88 lbf•ft | 110 lbf•ft | 130 lbf•ft | 165 lbf•ft | 150 lbf•ft | 190 lbf•ft |
| M16 | 135 N•m | 175 N•m | 260 N•m | 330 N•m | 375 N•m | 475 N•m | 440 N•m | 560 N•m |
| | 100 lbf•ft | 125 lbf•ft | 195 lbf•ft | 250 lbf•ft | 275 lbf•ft | 350 lbf•ft | 325 lbf•ft | 410 lbf•ft |
| M18 | 135 N•m | 175 N•m | 260 N•m | 330 N•m | 375 N•m | 475 N•m | 440 N•m | 560 N•m |
| | 100 lbf•ft | 125 lbf•ft | 195 lbf•ft | 250 lbf•ft | 275 lbf•ft | 350 lbf•ft | 325 lbf•ft | 410 lbf•ft |
| M20 | 190 N•m | 240 N•m | 375 N•m | 475 N•m | 530 N•m | 675 N•m | 625 N•m | 800 N•m |
| | 140 lbf•ft | 180 lbf•ft | 275 lbf•ft | 350 lbf•ft | 400 lbf•ft | 500 lbf•ft | 460 lbf•ft | 580 lbf•ft |
| M22 | 260 N•m | 330 N•m | 510 N•m | 650 N•m | 725 N•m | 925 N•m | 850 N•m | 1075 N•m |
| | 190 lbf•ft | 250 lbf•ft | 375 lbf•ft | 475 lbf•ft | 540 lbf•ft | 675 lbf•ft | 625 lbf•ft | 800 lbf•ft |
| M24 | 330 N•m | 425 N•m | 650 N•m | 825 N•m | 925 N•m | 1150 N•m | 1075 N•m | 1350 N•m |
| | 250 lbf•ft | 310 lbf•ft | 475 lbf•ft | 600 lbf•ft | 675 lbf•ft | 850 lbf•ft | 800 lbf•ft | 1000 lbf•ft |
| M27 | 490 N•m | 625 N•m | 950 N•m | 1200 N•m | 1350 N•m | 1700 N•m | 1600 N•m | 2000 N•m |
| | 360 lbf•ft | 450 lbf•ft | 700 lbf•ft | 875 lbf•ft | 1000 lbf•ft | 1250 lbf•ft | 1150 lbf•ft | 1500 lbf•ft |
| M30 | 675 N•m | 850 N•m | 1300 N•m | 1650 N•m | 1850 N•m | 2300 N•m | 2150 N•m | 2700 N•m |
| | 490 lbf•ft | 625 lbf•ft | 950 lbf•ft | 1200 lbf•ft | 1350 lbf•ft | 1700 lbf•ft | 1600 lbf•ft | 2000 lbf•ft |
| M33 | 900 N•m | 1150 N•m | 1750 N•m | 2200 N•m | 2500 N•m | 3150 N•m | 2900 N•m | 3700 N•m |
| | 675 lbf•ft | 850 lbf•ft | 1300 lbf•ft | 1650 lbf•ft | 1850 lbf•ft | 2350 lbf•ft | 2150 lbf•ft | 2750 lbf•ft |
| M36 | 1150 N•m | 1450 N•m | 2250 N•m | 2850 N•m | 3200 N•m | 4050 N•m | 3750 N•m | 4750 N•m |
| | 850 lbf•ft | 1075 lbf•ft | 1650 lbf•ft | 2100 lbf•ft | 2350 lbf•ft | 3000 lbf•ft | 2750 lbf•ft | 3500 lbf•ft |



Warranty

MANUFACTURER'S LIMITED WARRANTY

BLUE DIAMOND® ATTACHMENTS, a manufacturer of quality attachments, warrants new BLUE DIAMOND® ATTACHMENTS products and/or attachments at the time of delivery to the original purchaser, to be free from defects in material and workmanship when properly set up and operated in accordance with the recommendations set forth by BLUE DIAMOND® ATTACHMENTS, LLC.

BLUE DIAMOND® ATTACHMENTS liability for any defect with respect to accepted goods shall be limited to repairing the goods at a BLUE DIAMOND® ATTACHMENTS designated location or at an authorized dealer location, or replacing them, as BLUE DIAMOND® ATTACHMENTS shall elect. The above shall be in accordance with BLUE DIAMOND® ATTACHMENTS warranty adjustment policies. BLUE DIAMOND® ATTACHMENTS obligation shall terminate after the specific time below for the Extreme Duty Series 2 Auger after the delivery of the goods to original purchaser.

- Twelve (12) months for parts and labor
- Thirty-six (36) months for motor
- Forty-eight (48) months for planetary drive
- Sixty (60) months for gearbox
- Lifetime for output shaft pullout

This warranty shall not apply to any machine or attachment which shall have been repaired or altered outside the BLUE DIAMOND® ATTACHMENTS factory or authorized BLUE DIAMOND® ATTACHMENTS dealership or in any way so as in BLUE DIAMOND® ATTACHMENTS judgment, to affect its stability or reliability, nor which has been subject to misuse, negligence or accident beyond the company recommended machine rated capacity.

WARRANTY CLAIM

To submit a warranty claim, a claim must be filed with BLUE DIAMOND® ATTACHMENTS before work is performed. The BLUE DIAMOND® PRODUCT SUPPORT TEAM will advise repairs and applicable parts exchanges. Tampering with the failed part may void the warranty. This warranty does not include freight or delivery charges incurred when returning machinery for servicing. Dealer mileage, service calls, and pickup/delivery charges are the customers' responsibility.

EXCLUSIONS OF WARRANTY

Except as otherwise expressly stated herein, BLUE DIAMOND® ATTACHMENTS makes no representation or warranty of any kind, expressed or implied, AND MAKES NO WARRANTY OF MERCHANTABILITY IN RESPECT TO ITS MACHINERY AND/OR ATTACHMENTS ARE FIT FOR ANY PARTICULAR PURPOSE. BLUE DIAMOND® ATTACHMENTS shall not be liable for incidental or consequential damages for any breach or warranty, including but not limited to inconvenience, rental of replacement equipment, loss of profits or other commercial loss. Upon purchase, the buyer assumes all liability for all personal injury and property resulting from the handling, possession, or use of the goods by the buyer.

No agent, employee, or representative of BLUE DIAMOND® ATTACHMENTS has any authority to bind BLUE DIAMOND® ATTACHMENTS to any affirmation, representation, or warranty concerning its machinery and/or attachments except as specifically set forth herein.

This warranty policy supersedes any previous documents. Please see bluediamondattachments.com/warranty-policies for the most up to date warranty information.

NOTE: Blue Diamond® Attachments is a trademark of BLUE DIAMOND® ATTACHMENTS



QUALITY | DEPENDABILITY | INTEGRITY

Blue Diamond® Attachments
4512 Anderson Road, Knoxville, TN 37918
888-376-7027